

**GREENVILLE UTILITIES COMMISSION
GREENVILLE, NORTH CAROLINA**

**SPECIFICATION AND BID DOCUMENTS
FOR THE RELOCATION OF
12.47 KV DISTRIBUTION AND 115 KV
TRANSMISSION STRUCTURES
ALONG ALLEN ROAD**

ISSUED FOR BIDS

ADVERTISEMENT FOR BIDS

Sealed proposals will be received in the Office of the Procurement Manager, Greenville Utilities Commission, 401 S. Greene Street, Greenville, North Carolina 27834 until 3:00 PM (EDST) on May 30, 2024 and immediately thereafter publicly opened and read for the Relocation of 12.47 kV Distribution and Transmission Structures along Allen Road.

Instructions for submitting bids and complete specifications will be available in the Office of the Procurement Manager, Greenville Utilities Commission, 401 S. Greene Street, Greenville, North Carolina during regular office hours, which are 8:30AM – 5:00PM Monday through Friday.

Greenville Utilities Commission reserves the right to reject any or all bids. **Late bids will not be considered.**

PRE-BID MEETING – A Pre-Bid meeting will be held at Greenville Utilities Commission, New Operations Center, Engineering Building, 3355 NC 43N, Greenville, North Carolina 27834 on **Wednesday, May 22, 2024 at 1:00 pm to 3:00 pm (EDST).**

The intent of the Pre-Bid Meeting is to allow the bidders an opportunity to ask questions and make clarifications prior to submitting a bid.

Only portions of the bid/contract will be discussed. Lack of discussion or clarification of any portion of the bid/contract does not relieve the Bidder from conforming to the provisions of the same.

Questions regarding this Request for Bid (RFB) should be received by or before noon, May 15, 2024. All questions shall be directed via e-mail to the attention of Cleve Haddock, Lifetime CLGPO, Procurement Manager at: haddocgc@guc.com, (252) 551-1533.

**GREENVILLE UTILITIES COMMISSION
GREENVILLE, NORTH CAROLINA**

**SPECIFICATION AND BID DOCUMENTS FOR THE RELOCATION OF 12.47 KV
DISTRIBUTION AND 115 KV TRANSMISSION STRUCTURES ALONG ALLEN RD.**

TABLE OF CONTENTS

REQUEST FOR PROPOSAL

General Instructions	GI-1
General Conditions	GC-1
Special Conditions	SC-1
Contract.....	C-1

FORM OF PROPOSAL

Proposal.....	P-1
Terms and Conditions	P-2
Addenda/Clarifications/Bulletins.....	P-5
Labor, Material, and Unit Pricing Proposals	P-6, P-7
Proposed Construction Schedule	P-13
Certificate of Insurance.....	P-14
Copy of Contractor’s License	P-15
Form of Exceptions.....	P-16
Equal Employment Opportunity Affidavit	P-17
Good Faith Efforts	P-18
Proposed Project Management Staff.....	P-34
References.....	P-35
List of Subcontractors	P-36
E-Verify Compliance	P-37
Iran Divestment Act Certification.....	P-38
Bid Bond, Original.....	P-39
Performance Bond/Payment Bond.....	P-40

TECHNICAL SPECIFICATIONS

Technical Specifications – Installation Specifications	S-1
Technical Specifications – Material Specifications	S-13

APPENDICES

- A. Detail Construction Drawings
- B. Standard Pole Framing
- C. Standard Assembly Drawings
- D. Plan & Profile, 22-33461-PP01-A
- E. Pole Assembly Drawing, 22-33461-SK01-01
- F. Pole Bid Drawings STR. NO. 42, 22-33461-1201-01
- G. Pole Bid Drawings STR. NO. 42, 22-33461-1201-02
- H. Sag-Tension Charts
- I. Soil Boring Report

SECTION I

GENERAL INSTRUCTIONS FOR FORMAL BIDS

RELATED TO THE RELOCATION OF 12.47 kV DISTRIBUTION AND 115 kV

TRANSMISSION STRUCTURES ALONG ALLEN ROAD CONTRACT

1. NOTICE TO BIDDERS

Sealed bids, subject to the conditions made a part hereof, will be received in the Office of the Procurement Manager, Greenville Utilities Commission, 401 S. Greene Street, Greenville, North Carolina 27834 until 3:00 PM (EDST) on May 30, 2024, the day of opening. Bids submitted in a fax or e-mail in response to this Invitation for Bids **will not be acceptable**.

2. STANDARD FORMS REQUIRED

Each bidder must submit a proposal on the enclosed bid forms. **The bid must be signed by an authorized official of the firm. Return only the attached Proposal Form. Do not return the Advertisement for Bids, Instructions to Bidders or Specifications.**

3. PREPARATION OF BID

Bids must be in sealed envelopes clearly marked on the outside with the name of the bid and the bid opening date and time. Bid shall be addressed to PROCUREMENT MANAGER, GREENVILLE UTILITIES COMMISSION, 401 S. GREENE STREET, GREENVILLE, NORTH CAROLINA 27834.

4. TIME FOR OPENING BIDS

Bids will be opened promptly and read at the hour and on the date set forth in the advertisement in the Office of the Procurement Manager, Greenville Utilities Main Office, 401 S. Greene Street, Greenville, North Carolina.

5. BID SECURITY

- 5.1. Each Proposal shall be accompanied by a cashier's check, or certified check drawn on a bank or trust company insured by the Federal Deposit Insurance Corporation, or the Savings Association Insurance Fund, or an original signed/sealed Bid Bond in an amount equal to not less than five percent (5%) of the total amount of the Proposal; said deposit to be retained by the Owner as liquidated damages in event of failure of the Successful Bidder to execute the Contract within ten (10) days after the award.

- 5.2. Bid Bond shall be conditioned that the Surety will upon demand forthwith make payment to the Obligee upon said Bond if the Bidder fails to execute the Contract in accordance with the Bid Bond, and upon failure to immediately make payment, the Surety shall pay to the Obligee an amount equal to double the amount of said Bond. Standard Form of Bid Bond is included in these Specifications.
- 5.3. Only one (1) bid Surety is required, the amount of which shall be based on the total amount of all bid schedules.

6. BULLETINS AND ADDENDA

Any bulletins issued during the time of bidding or addenda to Specifications are to be considered covered in the Proposal, and in executing a Contract will become a part thereof. Receipt of addenda shall be acknowledged by the bidder in the *Form of Proposal*.

7. NC SALES TAX

Do not include NC sales taxes in bid figure; however, Greenville Utilities Commission (GUC) does pay sales tax. Sales tax should be added to the invoice as a separate item.

8. FEDERAL EXCISE TAX

GUC is exempt from Federal Excise Tax and will issue a Federal Exemption Certificate upon request to the successful bidder.

9. FORM OF EXCEPTIONS

Proposals shall include a *Form of Exceptions* utilizing forms provided which shall itemize each exception from the Specifications. The Form of Exceptions shall state the section, subsection, and paragraph designations from the part of the Specifications to which exception is taken and explain in detail the nature of the exception. A copy of this *Form of Exceptions* is included in the Form of Proposals. Exceptions will not necessarily eliminate a Bidder from consideration, even if bids without exceptions are received from others. The treatment of exceptions will be based entirely on the overall best interests of the Owner.

10. DISCREPANCY

Should the Bidder find discrepancies in or omissions from the Drawings or Documents or should he be in doubt as to their meaning, he shall at once notify the Engineer who will send written instructions to all Bidders. Neither the Owner nor the Engineer will be responsible for any oral instructions. If Plans and Specifications are found to disagree after Contract is awarded, the Engineer shall be the judge as to what was intended. The Successful Bidder is hereby made responsible for the furnishing of the necessary labor, tools and equipment reasonably inferred or evidently necessary for the proper execution and completion of the work; for any additional work involved in the correction of apparent errors or

inconsistencies, and in executing the true intent and meaning of the Drawings and Specifications as interpreted by the Engineer and all such labor and equipment shall be provided at the Contractor's expense, and under no condition will any such labor and equipment be allowed as an extra.

11. EVALUATION AND AWARD OF BIDS

- 11.1. The award of the Contract will be made to the lowest responsible, responsive Bidder as soon as practicable. The bid shall be awarded to the Bidder who, in the judgment of the Owner, offers the best value to the Owner. Factors to be considered by the Owner are specified in Paragraph 11.3. The Owner reserves the right to reject any and all bids.
- 11.2. The Owner reserves the right to waive minor irregularities or minor errors in any Proposal if it appears to the Owner that such irregularities or errors were made through inadvertence. Any such irregularities or errors so waived must be corrected on the Proposal prior to its acceptance by the Owner.
- 11.3. In estimating the lowest cost to the Owner as one of the factors in deciding the award of the Contract, the Owner will consider, in addition to the prices quoted in the Proposal, the following:
 - 11.3.1. Completion date
 - 11.3.2. Adherence to the Plans and Specifications
 - 11.3.3. Contractor capabilities, crew experience, and past performance
 - 11.3.4. Conditional quotations (Only firm fixed prices in U.S. dollars)
 - 11.3.5. Any additional factors deemed appropriate by the Owner.
- 11.4. In the event the Bidder proposes any change or deviation from the Engineer's Plans and Specifications, such proposed changes or deviations must be submitted at the time bids are opened on the *Form of Exceptions* included. The Owner reserves the right to reject any proposed changes or deviations. All exceptions must be stated on the *Form of Exceptions*. Failure to provide a *Form of Exceptions* with the Proposal shall imply strict adherence to all details of the Plans and Specifications.
- 11.5. The Contract, when awarded, shall be deemed to include the Specifications for the equipment, and the Bidder shall not claim any modification thereof resulting from any representative or promise made at any time by any officer, agent, or employee of the Owner or by any other person.

12. PROMPT PAYMENT DISCOUNTS

Bidders are urged to compute all discounts into the price offered. If a prompt payment discount is offered, it may be considered in the award of the contract.

13. NUMERICAL ERRORS

In the case of a discrepancy between a unit price and the extension (the unit price multiplied by the number of units) the unit price governs. In the case where numerical bids are stated both in numbers and in words, the words govern.

14. BID WITHDRAWAL

If, within 24 hours after bids are opened, any Bidder files a duly signed written notice with the Owner and promptly thereafter demonstrates to the reasonable satisfaction of the Owner that there was a substantial mistake in the preparation of its bid, that Bidder will not be permitted to modify its bid, but may withdraw its bid in its entirety, and the Bid Security will be returned. Thereafter, the bidder will be disqualified from further bidding on the installation of the project herein specified.

15. MINORITY BUSINESS PARTICIPATION PROGRAM

GUC has adopted an Affirmative Action and Minority and Women Business Enterprise Plan (M/WBE) Program. Firms submitting a proposal are attesting that they also have taken affirmative action to ensure equality of opportunity in all aspects of employment, and to utilize M/WBE suppliers of materials and/or labor.

16. PERFORMANCE AND PAYMENT BONDS

- 16.1. The Successful Bidder shall be required to furnish separate Performance and Payment Bonds executed on the forms bound herein in amounts at least equal to one hundred percent (100%) of the Contract price as security for the faithful performance of this Contract and as security for the payment of all persons performing labor and furnishing materials and equipment in connection with this Contract.
- 16.2. Performance and Payment Bonds shall be with a Surety company authorized and licensed to do business in the State of North Carolina and shall be for the full Contract sum.

17. EXAMINATION OF CONDITIONS

Prior to the submission of the Proposal, the Bidder shall make and shall be deemed to have made a careful examination of the Plans and Specifications on file with the Owner and with the Engineer, and all other matters that may affect the cost and the time of completion of the work.

18. SUBCONTRACTORS

The Bidder shall include in the Proposal a listing of all subcontractors (if any) and their respective support services to be utilized during the project. All subcontractors will be subject to approval by the Owner and Engineer.

19. COMPLETION

- 19.1. The award of this Contract shall be issued as soon as possible, subsequent to the bid opening, by issuance of written contract to the Contractor by the Engineer or notification from the Owner. Work on the project shall begin after award of Contract and no later than June 24, 2024.
- 19.2. The completion date for the projects' on-site activities shall be June 7, 2025.
- 19.3. Time for completion shall be extended for delays due to bad weather days or other special cases with the written consent of the Owner and/or Engineer.
- 19.4. The Contractor shall include in the Proposal a project construction schedule using the completion date above, indicating each major construction activity with duration and the total number of calendar days of construction time he proposes to perform his work based on the above completion date.

20. LIQUIDATED DAMAGES

Time is of the essence, and it is critical that the work be performed on schedule and time is allowed for the completion of the work in the Contract Agreement included herewith. Damages for delay shall be at the rate of five-hundred dollars (\$500.00) per calendar day for failure of the Contractor to complete the work within the Construction Schedule. No credit shall be given for early completion of the work.

21. BIDS TO BE RETAINED

No bid may be withdrawn after the scheduled closing time for the receipt of bids for a period of sixty (60) days pending the execution of a Contract by the Successful Bidder. Should the Successful Bidder default and not execute a Contract, the Contract will be offered to the next lowest responsible, responsive Bidder.

22. DELIVERY LOCATION

The prices quoted shall include delivery of any Contractor-furnished materials and equipment to the project site, and complete installation of said materials and equipment and installation of the Owner- furnished materials. The location of the distribution facilities is shown on the Vicinity Map in the Appendices.

23. FORM OF PROPOSAL

Those bids not received on the Form of Proposal contained herein will be considered unresponsive. The forms shall be filled out completely. Any omissions may cause the entire Proposal to be rejected

24. CONTRACTOR'S INSURANCE

- 24.1. General Liability: Commercial General Liability Insurance, (with coverage consistent with ISO Form CG 00 01 12 07 or its equivalent) with a limit of not less than One Million Dollars (\$1,000,000) per occurrence and Two Million Dollars (\$2,000,000) per project or per location general aggregate, and a deductible or self-insured retention not to exceed Twenty-five Thousand Dollars (\$25,000) per occurrence, covering liability for bodily injury and property damage, arising from premises, operations, independent contractors, personal injury/advertising injury, contractual liability, and products/completed operations for not less than two (2) years from the Substantial Completion Date.
- 24.2. Automobile Liability: Commercial Automobile Liability Insurance, including coverage for liability arising out of the use of owned (if any), non-owned, leased or hired automobiles, for both bodily injury and property damage in accordance with Applicable Legal Requirements, with a limit of not less than One Million Dollars (\$1,000,000) combined single limit per occurrence.
- 24.3. Workers Compensation: Worker's Compensation Insurance, with statutory limits, covering all of Subcontractor's employees, on terms and conditions as required by applicable Law and imposed by worker's compensation, occupational disease or similar laws, including the Longshore and Harbor Workers' Act, the Federal Employers' Liability and the Jones Act, if applicable.
- 24.4. Employers Liability: Employers' Liability Insurance with limits of not less than One Million Dollars (\$1,000,000) each accident for bodily injury by accident, One Million Dollars (\$1,000,000) each employee for bodily injury by disease, and One Million Dollars (\$1,000,000) policy limit.
- 24.5. Umbrella Liability: Subcontractor must provide an Umbrella form (not Excess Liability form) that provides additional liability for underlying General Liability, Auto Liability, and Employer Liability.
 - 24.5.1. Level 1 Contracts (Contract Value \$200,000 to \$499,999) - \$1,000,000
 - 24.5.2. Level 2 Contracts (Contract Value \$500,000 to \$999,999) - \$3,000,000
 - 24.5.3. Level 3 Contracts (Contract Value \$1,000,000 & up) - \$5,000,000

25. CONTRACTOR'S LICENSE

In accordance with the State of North Carolina General Statutes, Contractors performing work of this caliber in the State must be licensed to do so. A current copy of the Contractor's State of North Carolina Board for General Contractor's License must be submitted with this Proposal in the Form of Proposal. Additionally, a valid license must be maintained during the course of the work.

Contractor represents and warrants that it is fully experienced in projects of the nature, scope and magnitude of the Work, properly qualified, registered, licensed, equipped, organized and financed to perform the Work.

[Balance of Page Left Blank Intentionally]

GENERAL CONDITIONS

1. DRAWINGS AND SPECIFICATIONS

The Drawings and Specifications are complementary, one to the other. That which is shown on the Drawings or called for in the Specifications shall be as binding as if it were both called for and shown. The intention of the Drawings and Specifications is to include all labor, materials, transportation, equipment and any and all other items necessary to do a complete job which may include manufactured items and field service assistance. In case of discrepancy or disagreement in the Contract, the order of precedence shall be: Contract, Specifications, Drawings.

2. CLARIFICATIONS AND DETAILED DRAWINGS

In such cases where the nature of the work requires clarification by the Engineer, such clarification shall be furnished by the Engineer with reasonable promptness by means of written instructions or Detail Drawings or both. Clarifications and Drawings shall be consistent with the intent of Contract Documents and shall become a part thereof.

3. CHANGE OF DRAWINGS AND/OR SPECIFICATIONS

- 3.1. The Owner, or the Engineer on behalf of the Owner, may make changes to Drawings and/or Specifications after award of the Contract or while construction is in progress. The compensation for such changes shall be agreed upon in writing between the Contractor and the Owner prior to commencement of work involving the change. No payment shall be made to the Contractor for correcting work not in compliance with Specifications. Once the change of work has been agreed upon between all parties, the Engineer will initiate a change order.
- 3.2. Records of conditions above and below ground, water records or other observations which may have been made by or for Owner shall be made available to Contractor for its information, upon request. Site sub-surface conditions which differ materially from the results reasonably indicated in any reports furnished by Owner or undertaken by Contractor shall be deemed to be changed work.
- 3.3. Except as otherwise set forth in the Contract, all loss or damage to Contractor arising out of the Work or from the action of the elements, or from any unforeseen circumstance in the prosecution of the Work including inefficiencies or claims of inefficiencies, shall be sustained and borne by Contractor at its own cost and expense.

4. COPIES OF BID DOCUMENTS

The Engineer will furnish free of charge to each pre-qualified Bidder one (1) copy of bid documents. Additional sets of these Specifications for approved Bidders and sets for Bidders seeking approval may be obtained upon request for a non-refundable payment of Fifty Dollars (\$50) per set.

5. WORKING DRAWINGS AND SPECIFICATIONS AT THE JOB SITE

Contractor shall maintain, in readable condition at his office, one (1) complete set of as-built working Drawings and Specifications for his work. Such Drawings and Specifications shall be available for use by the Engineer or Owner. During construction, the Contractor will work diligently to keep the Owner abreast of electric system conditions, so as not to interfere with normal or emergency operations.

6. OWNERSHIP OF DRAWINGS AND SPECIFICATIONS

All Drawings and Specifications are instruments of service and remain the property of the Engineer whose name appears thereon. The use of these instruments on work other than this Contract without permission is prohibited. All copies of Drawings and Specifications other than Contract copies shall be returned to the Engineer upon request after completion of the work.

7. MATERIALS, EQUIPMENT, AND EMPLOYEES

7.1. The Contractor shall, unless otherwise specified, supply and pay for all labor, equipment, transportation, tools, apparatus, lights, heat, sanitary facilities, water, and incidentals necessary for the entire proper and substantial completion of his work. The Contractor shall install, maintain, and remove all equipment of the construction and be responsible for the safe, proper, and lawful construction, maintenance, and use of same. The Contractor shall construct, in the best and most workmanlike manner, a complete job and everything incidental thereto, as shown on the Plans, stated in the Specifications, or reasonably implied therefrom, all in accordance with the Contract Documents. Some of the major material items required for the work will be furnished by the Owner as outlined in the Technical Specifications. All other necessary materials are to be furnished by the Contractor as outlined in the Technical Specifications.

7.2. The Contractor shall not re-use any "removed" materials in the completion of this project unless indicated as a transfer unit on the construction drawings. Materials damaged or lost during construction of the work due to carelessness of the Contractor's personnel, shall be replaced in kind by the Contractor at no cost to the Owner.

7.3. If at any time during the construction and completion of the work covered by these Specifications, the conduct of any workman of the various crafts is

adjudged ungentlemanly and a nuisance to the Owner or the Engineer, or if any workman is considered incompetent or detrimental to the work, the Contractor shall order such parties to be immediately removed from the grounds.

7.4. Any superintendent or foreman of the Contractor who ignores or refuses to follow written instructions of the Owner or the Engineer or his representative at the site shall be immediately removed and replaced.

7.5. The Contractor shall always ensure that he has sufficient crew compliments, both in terms of numbers and experience of personnel to perform work tasks safely. both for workers and the general public. Any instance noted to the contrary of this requirement may result in the complete shutdown of work on the project.

8. ROYALTIES, LICENSE, AND PATENTS

It is the intention of the Contract Documents that the work covered herein will not constitute in any way on an infringement on any patent whatsoever. The Contractor shall protect and save harmless the Owner against suit on account of alleged or actual infringement. The Contractor shall pay all royalties and/or license fees required on account of patented articles or processes, whether the patent rights are evidenced hereinafter.

9. INDEMNIFICATION

Bidder agrees to indemnify and save GUC of the City of Greenville, Pitt County, North Carolina, and the City of Greenville, North Carolina, its co-owners, joint-venturers, agents, employees, and insurance carriers harmless from any and all Third Party claims, actions, costs, expenses, including reasonable attorney fees, judgments, or other damages resulting from injury to any person (including injury resulting in death), or damage (including loss or destruction) to third party tangible property arising out of the negligent performance of the terms of this Contract by Bidder; including, but not limited to, Bidder's employees, agents, subcontractors, and others designated by Bidder to perform work or services in, about, or attendant to, the work and services under the terms of this Contract. Bidder shall not be held responsible for any losses, expenses, claims, subrogation, actions, costs, judgments, or other damages, directly and proximately caused by the negligence of Greenville Utilities Commission of the City of Greenville, Pitt County, North Carolina. Insurance covering this indemnity agreement by Bidder in favor of Greenville Utilities Commission of the City of Greenville, Pitt County, North Carolina, and the City of Greenville, North Carolina, shall be provided by the Bidder.

10. SURVEYS

Unless otherwise specified, the Owner, will furnish all surveys and locations for locating the principal component parts of the work. Stakes missing at the time of construction will be replaced within a reasonable amount of time after notification by the Contractor.

11. UNCORRECTED FAULTY WORK

The Contractor shall be notified of faulty or damaged work and shall have the option to respond in a reasonable period. Should the correction of faulty or damaged work be considered inadvisable or inexpedient by the Owner or the Engineer, the Owner shall be reimbursed by the Contractor for the same by a deduction in the Contract prices arrived at by a fair estimate of the probable cost of correction, approved by the Engineer.

12. DELAYS AND EXTENSION OF TIME

- 12.1. The time to be allowed for construction of these facilities is stated in the Instructions to Bidders. The Contractor, upon notice of award of Contract, shall prepare a construction schedule based on the allowed time, and submit such schedule to the Engineer for approval. A Pre-Construction Conference will be scheduled for all parties concerned.
- 12.2. If the Contractor is delayed at any time in the progress of the work by any act of negligence by the Owner or the Engineer, or by any separate Contractor employed by the Owner or by changes ordered in the work, then the time of completion shall be extended for such reasonable time as the Engineer may decide.
- 12.3. No extension of time for completion will be made for ordinary delays and accidents. Extensions may be granted for delays ordered by the Owner or the Engineer if the request has been made in writing within forty-eight (48) hours after the order to cease work has been given.

13. LIQUIDATED DAMAGES

Time is of the essence, and it is critical that the work be performed on schedule and time is allowed for the completion of the work in the Contract Agreement included herewith. Damages for delay shall be at the rate of five-hundred dollars (\$500.00) per calendar day for failure of the Contractor to complete the work within the Construction Schedule. No credit shall be given for early completion of the work.

14. CORRECTION OF WORK BEFORE FINAL PAYMENT

- 14.1. Any work, materials, or other parts of the work which have been condemned or declared not in accordance with the Contract by the Owner or the Engineer shall be removed from the work site by the Contractor and shall be immediately replaced by new work in accordance with the Contract at no additional cost to the Owner. Work or property of others or the Owner damaged or destroyed by virtue of such faulty work shall be made good at the expense of the Contractor whose work is faulty.
- 14.2. Correction of condemned work described above shall commence within twenty-four (24) hours after receipt of notice from the Owner or the Engineer and shall be pursued to completion.
- 14.3. Final payment will not be made until certificates of the engineer have been duly issued

15. CORRECTION OF WORK AFTER FINAL PAYMENT

Neither the final certificate, final payment, acceptance of the premises by the Owner, nor any provision of the Contract, nor any other act or instrument of the Owner or Engineer shall relieve the Contractor from responsibility for negligence, or faulty materials or workmanship, or failure to comply with the Drawings and Specifications. He shall correct or make good any defects due thereto and repair any damage resulting there from which may appear during the period of the guarantee following final acceptance of the work by the Owner. The Owner will report any defects as they may appear to the Engineer who will give the instructions for a time limit for completion of corrections to the Contractor.

16. THE OWNER'S RIGHT TO PERFORM WORK

- 16.1. The Owner may perform or have performed by others work which is described in the Specifications to be performed by the Contractor, due to early delivery of equipment prior to the execution of this Contract. Upon the execution of the contract, the work performed will be deducted from the Contractor's price by the unit price set forth in the *Form of Proposal*.
- 16.2. If during the progress of the work or during the period of guarantee, the Contractor fails to execute the work properly or to perform any provision of the Contract, the Owner, after five (5) days' written notice to the Contractor from

the Engineer or the Owner, may perform or have performed that portion of the work and may deduct the cost thereof from any amounts due or to become due the Contractor, such action and cost of same having been first approved by the Engineer. Should the cost of such action of the Owner exceed the amount due or to become due the Contractor, then the Contractor or his surety, or both, shall be liable for and shall pay to the Owner the amount of said excess.

17. CONTRACTOR'S AFFIDAVIT

The final payment of retained amount due the Contractor on account of the Contract shall not become due until the Contractor has furnished to the Owner, with a copy to the Engineer, an affidavit signed, sworn and notarized to the effect that all payments for materials, services, or any other reason in connection with his Contract have been satisfied and that no claims or liens exist against the Contractor in connection with this Contract. In the event that the Contractor cannot obtain similar affidavits from Subcontractors to protect the Contractor and the Owner from possible liens or claims against the Subcontractor, the Contractor shall state in his affidavit that no claims or liens exist against any Subcontractor to the best of his (the Contractor's) knowledge and if any appear afterwards, the Contractor shall save the Owner harmless on account thereof.

18. ASSIGNMENTS

The Contractor shall not assign any portion of this Contract nor subcontract it in its entirety. Except as may be required under terms of the Payment and/or Performance Bond, no funds or sums of money due or to become due the Contractor under this Contract may be assigned.

19. GUARANTEE

The Contractor shall guarantee his work against defect due to faulty workmanship or negligence for a period of two (2) years following final acceptance of the work. He shall make good such defective workmanship and any damage resulting therefrom without cost to the Owner.

20. ENGINEER'S STATUS

The Engineer shall, within a reasonable time after their presentation to him, make decisions on all claims of the Contractor and on all other matters relating to the execution and progress of the work or the interpretation of the Contract Documents. All such decisions by the Engineer shall be final.

21. ENGINEER'S DECISIONS

The Engineer shall, within a reasonable time after their presentation to him, make decisions on all claims of the Contractor and on all other matters relating to the execution and progress of the work or the interpretation of the Contract Documents. All such decisions by the Engineer shall be final.

22. RIGHT-OF-WAY

The Owner will obtain all easements and/or rights-of-way required for the project.

23. ACCIDENTS

The Contractor shall provide at the site such equipment and medical facilities as are necessary to supply first-aid service to anyone who may be injured in connection with the work. The Contractor will provide a written report to the Owner of all accidents within twenty-four (24) hours of the event.

24. EQUAL EMPLOYMENT OPPORTUNITY

During the performance of this Contract, the Contractor agrees as follows:

- 24.1. The Contractor will not discriminate against any employee or applicant for employment because of race, color, religion, sex, national origin, political affiliation or belief, age, or physical handicap. The Contractor will take affirmative action to ensure that applicants are employed and that employees are treated during employment without regard to race, color, religion, sex, national origin, political affiliation or belief, age, or physical handicap. Such action shall include but not be limited to the following employment, upgrading, demotion or transfer, recruitment or recruitment advertising, layoff or termination, rates of pay or other forms of compensation and selection for training, including apprenticeship. The Contractor agrees to post in conspicuous places available to employees and applicants for employment notices setting forth the provisions of the nondiscrimination clause.
- 24.2. The Contractor will, in all solicitations or advertisements for employees placed by or on behalf of the Contractor, state that all qualified applicants will receive consideration for employment without regard to race, color, religion, sex, national origin, political affiliation or belief, age, or physical handicap.

- 24.3. The Contractor will send to each labor union or representative of workers with which he has a collective bargaining agreement or other contract or other understanding, a notice advertising the labor union or workers' representative of the Contractor's commitments under the Equal Employment Opportunity Section of this Contract and shall post copies of the notice in conspicuous places available to employees and applicants for employment.
- 24.4. In the event of the Contractor's noncompliance with the nondiscrimination clauses of this Contract or with any of such rules, regulations, or orders, this Contract may be canceled, terminated, or suspended in whole or in part and the Contractor may be declared ineligible for further Owner contracts.
- 24.5. The owner has adopted an Affirmative Action & Minority & Women Business Enterprise Plan (M/WBE) Program. Contractors submitting a proposal are attesting that they also have taken affirmative action to ensure equality of opportunity in all aspects of employment, and to utilize M/WBE supplies of material and/or labor.

25. MEDIATION/BINDING ARBITRATION

- 25.1. In the event of any dispute between the Parties, the Parties agree to submit any dispute to non-binding mediation before a mutually agreeable Mediator prior to initiating litigation. If the Parties are unable to agree upon a Mediator within thirty (30) days after demand therefore, either Party may petition a Court of competent jurisdiction for the designation of a qualified Mediator for these purposes. Each Party shall bear its own costs and expenses of participating in the mediation (including, without limitation, reasonable attorneys' fees), and each Party shall bear one-half (1/2) of the costs and expenses of the Mediator. Unless otherwise agreed, the Parties will hold the mediation in Greenville, North Carolina. The matters discussed or revealed in the mediation session shall not be disclosed in any subsequent litigation.
- 25.2. In the event the matter is not resolved in mediation, either Party may request arbitration. The parties shall jointly select an Arbitrator and shall be bound by the decision of the Arbitrator with respect to any dispute between the parties with respect to this Agreement. If the parties are unable to mutually agree upon an Arbitrator, the Parties shall each select an Arbitrator, and the two Arbitrators so selected shall select a third Arbitrator, and the decision of the majority of the Arbitrators shall be conclusive and binding upon the Parties. The Parties at all times agree to equally split the costs of any Arbitrator(s) selected in an effort to

resolve the dispute between the Parties. Any party desiring to resolve a dispute under the terms of this Agreement shall notify the other Party in writing, and the Parties shall seek to agree upon a mutually agreed-upon Arbitrator within a period of ten (10) days from the date of such written demand. If the Parties are unable to agree within such ten (10) day period, the Parties shall each select an Arbitrator, and the two (2) Arbitrators so selected shall select a third Arbitrator within fifteen (15) days from the date of the written demand for arbitration, and a decision shall be rendered by the Arbitrator(s) so selected within five (5) days after such Arbitrator(s) is selected.

26. GOVERNMENT RESTRICTIONS

In the event any Governmental restrictions may be imposed which would necessitate alteration of the material, quality, workmanship, or performance of the items offered on this bid prior to their delivery, it shall be the responsibility of the successful Bidder to notify the GUC Procurement Manager, at once, indicating in its letter the specific regulation which required such alterations. GUC reserves the right to accept any such alterations, including any price adjustments occasioned thereby, or, in the sole discretion of GUC, to cancel the contract.

27. PATENTS AND COPYRIGHTS

The Bidder shall hold and save GUC, its officers, agents, and employees, harmless from liability of any kind, including costs and expenses, including reasonable attorney fees, on account of any copyrighted articles or any patented or unpatented invention, device or appliance manufactured or used in the performance of this contract.

28. PATENT AND COPYRIGHT INDEMNITY

The Bidder will defend or settle, at its own expense, any action brought against GUC to the extent that it is based on a claim that the product(s) provided pursuant to this agreement infringe any U.S. copyright or patent; and will pay those costs, damages, and attorney fees finally awarded against GUC in any such action attributable to any such claim, but such defense, settlements, and payments are conditioned on the following: (1) that Bidder shall be notified promptly in writing by GUC of any such claim; (2) that Bidder shall have sole control of the defense of any action on such claim and of all negotiations for its settlement or compromise; (3) that GUC shall cooperate with Bidder in a reasonable way to facilitate the settlement of defense of such claim; (4) that such claim does not arise from GUC modifications not authorized by the Bidder or from the use of combination of products provided by the Bidder with products provided by GUC or by others; and (5) should such

product(s) become, or in the Bidder's opinion likely to become, the subject of such claim of infringement, then GUC shall permit Bidder, at Bidder's option and expense, either to procure for GUC the right to continue using the product(s), or replace or modify the same so that it becomes non-infringing and performs in a substantially similar manner to the original product.

29. EXCEPTIONS

All proposals are subject to the terms and conditions outlined herein. All responses will be controlled by such terms and conditions and the submission of other terms and conditions, price catalogs, and other documents as part of a Bidder's response will be waived and have no effect on this Request for Proposal or any other contract that may be awarded resulting from this solicitation. The submission of any other terms and conditions by a Bidder may be grounds for rejection of the Bidder's proposal. The Bidder specifically agrees to the terms and conditions set forth in this set of Terms and Conditions by affixing its name on the signatory page contained herein.

30. CONFIDENTIAL INFORMATION

GUC will keep trade secrets which the Bidder does not wish to be disclosed, except as provided by statute and rule of law. Each page shall be identified in boldface at the top and bottom as "CONFIDENTIAL" by the Bidder. Cost information shall not be deemed confidential. The determination of whether a matter is confidential will be determined by North Carolina law.

31. ASSIGNMENT

No assignment of the Bidder's obligations or the Bidder's right to receive payment hereunder shall be permitted without the express written consent of GUC, provided however, upon written request approved by the GUC Procurement Manager, solely as a convenience to the Bidder, GUC may:

- 31.1. Forward the Bidder's payment check directly to any person or entity designated by the Bidder, and
- 31.2. Include any person or entity designated by Bidder as a joint payee on the Bidder's payment check.

31.3. In no event shall such approval and action obligate GUC to anyone other than the Bidder, and the Bidder shall remain responsible for fulfillment of all contract obligations.

32. AVAILABILITY OF FUNDS

Any and all payments of compensation of this specific transaction and any continuation or any renewal or extension are dependent upon and subject to the allocation of GUC funds for the purpose set forth in this Agreement.

33. GOVERNING LAWS

All contracts, transactions, agreements, etc., are made under and shall be governed by and construed in accordance with the laws of the State of North Carolina.

34. ADMINISTRATIVE CODE

Bids, proposals, and awards are subject to applicable provisions of the North Carolina Administrative Code.

35. EXECUTION

In the discretion of GUC, failure of a duly authorized official of Bidder to sign the Signatory Page may render the bid invalid.

36. CLARIFICATIONS/INTERPRETATIONS

Any and all questions regarding these Terms and Conditions must be addressed to the GUC Procurement Manager. Do not contact the user directly. **These Terms and Conditions are a complete statement of the parties' agreement and may only be modified in writing signed by Bidder and the GUC Procurement Manager.**

37. SITUS

The place of all contracts, transactions, agreements, their situs and forum, shall be North Carolina, where all matters, whether in contract or tort, relating to the validity, construction, interpretation, and enforcement shall be determined.

38. TERMINATION OF AGREEMENT

GUC or Bidder may terminate this Agreement for just cause at any time. Bidder will be paid for all time and expenses incurred as of the termination date. Termination for just cause by either party shall be by certified letter and shall be effective thirty (30) days after signed and acknowledged receipt of said letter. Just cause shall be based on reasonable grounds, and there must be a fair and honest cause or reason for such action. The causes for termination, include, but are not limited to:

- 38.1. Bidder's persistent failure to perform in accordance with the Terms and Conditions.
- 38.2. Bidder's disregard of laws and regulations related to this transaction
- 38.3. Bidder's substantial violation of the provisions of the Terms and Conditions.

39. FORCE MAJEURE

Neither party shall be considered in default in the performance of its obligations hereunder to the extent that the performance of any such obligation is prevented or delayed by any cause, existing or future, which is beyond the reasonable control of such party. In any such event of force majeure, the parties shall advise each other of such event, and the parties shall negotiate an equitable adjustment to their respective obligations under this Agreement.

40. INTEGRATED CONTRACT

These Terms and Conditions, Instructions to Bidders, Specifications, and the selected Bidder's bid represents the entire contract between the Parties. No verbal or other written agreement(s) shall be held to vary the provisions of this Agreement.

41. CONTRACT PROVISIONS

Each of the provisions of these Terms and Conditions shall apply to the full extent permitted by law, and the invalidity in whole or in part of any provision shall not affect the remainder of such provision or any other provisions.

42. E-VERIFY

E-Verify- I understand that E-Verify is the federal E-Verify program operated by the United States Department of Homeland Security and other federal agencies, or any successor or

equivalent program used to verify the work authorization of newly hired employees pursuant to federal law in accordance with NCGS §64-25 et seq. I am aware of and in compliance with the requirements of E-Verify and Article 2 of Chapter 64 of the North Carolina General Statutes. To the best of my knowledge, any subcontractors employed by me as a part of this contract are in compliance with the requirements of E-Verify and Article 2 of Chapter 64 of the North Carolina General Statutes.

43. IRAN DIVESTMENT ACT CERTIFICATION

By acceptance of this purchase order, Vendor/Contractor certifies that, as of the date of the purchase order or contract, it is not on the Final Divestment List as created by the State Treasurer pursuant to N.C.G.S. § 143-6A-4. In compliance with the requirements of the Iran Divestment Act and N.C.G.S. § 143C-6A-5(b), Vendor/Contractor shall not utilize in the performance of the contract any subcontractor that is identified on the Final Divestment List.

44. UNIFORM GUIDANCE

Contracts funded with federal grant or loan funds must be procured in a manner that conforms with all applicable federal laws, policies, and standards, including those under the Uniform Guidance (2 C.F.R. Part 200).

45. NOTICES

Notices to the Parties should be sent to the names and addresses specified below:

Mr. Cleve Haddock, Lifetime CLGPO
Procurement Manager
Greenville Utilities Commission
P.O. Box 1847
Greenville, NC 27835-1847

SPECIAL CONDITIONS

1. DEFECTIVE WORKMANSHIP

The acceptance of any workmanship by the Owner shall not preclude the subsequent rejection thereof if such workmanship shall be found to be defective after installation, and any such workmanship found defective before final acceptance of the work or within two (2) years after completion shall be remedied or replaced, as the case may be, by and at the expense of the Contractor. In the event of failure by the Contractor to do so, the Owner may remedy such defective workmanship and in such event the Contractor shall pay to the Owner the cost and expense thereof. The Contractor shall not be entitled to any payment hereunder so long as any defective workmanship, of which the Contractor shall have had notice, shall not have been remedied or replaced, as the case may be.

2. MATERIALS

- 2.1. At or prior to the commencement of construction, the Owner shall make available to the Contractor all materials which the Owner has on hand, and from time to time as such additional deliveries of materials, if any, are received by the Owner, the Owner shall make such materials available to the Contractor; Provided, however, that the Contractor or his authorized representative shall give to the Owner a receipt in such form as the Owner shall approve for all materials furnished to the Contractor by the Owner. Upon completion of the project, the Contractor shall return all materials furnished by the Owner which are in excess of those required for the construction. Excess will be determined by comparison of Contractor's material receipts with final inventory as approved by the Owner. The Contractor shall also return to the Owner all material, usable and scrap, removed during construction. The Contractor will reimburse the Owner, at the current invoice cost to the Owner, for loss and/or breakage resulting from Contractor's negligence, of materials furnished to the Contractor by the Owner.
- 2.2. The winning Bidder will use the material package supplied by the Owner. The structures and equipment lists are located in the Appendices.
- 2.3. The project foundation details (as applicable) will be provided to the Contractor prior to start of construction.

3. DEFECTIVE MATERIALS (SUPPLIED BY CONTRACTOR)

- 3.1. All materials supplied by the Contractor shall be subject to the inspection, tests and approval of the Owner. The Contractor shall furnish all information required concerning the nature or source of any materials and provide adequate facilities for testing and inspecting the materials at the plant of the Contractor.
- 3.2. The materials furnished hereunder shall become the property of the Owner when delivered at the point to which shipment is to be made. The Owner may, however, reject any materials and/or warranties of the Contractor and manufacturers. Recognition and subsequent rejection of any defective materials may occur either before or after incorporation of such materials into the work, provided such rejection is made within one (1) year of date of delivery of the materials. Upon any such rejection, the Contractor shall replace the rejected materials with materials complying with the Specification for Materials and warranties at the substation site. The Owner shall return the rejected materials F.O.B. truck at the same destination. In the event of the failure of the Contractor to so replace rejected materials, the Owner shall make such replacement and the cost and expense thereof shall be paid by and recoverable from the Contractor.

4. STORAGE OF MATERIALS

All material furnished by Owner shall be issued from the Owner's warehouse located at 701 Utility Way, Greenville, North Carolina. All driveways and public roadways must be kept clear. No parking, storage or staging of materials shall be placed in a driveway or roadway, causing said roadway impassable any time.

5. PROTECTION TO PERSONS AND PROPERTY

The Contractor shall always take all reasonable precautions for the safety of employees on the work and of the public, and shall comply with all applicable provisions of Federal, State, and Municipal safety laws and building and construction codes, as well as the safety rules and regulations of the Owner. All machinery and equipment and other physical hazards shall be guarded in accordance with the "Manual of Accident Prevention in Construction" of the Associated General Contractors of America unless such instructions are incompatible with Federal, State, or Municipal laws or regulations.

The following provisions shall not limit the generality of the above requirements:

- 5.1. The Contractor shall so conduct the construction as to cause the least possible obstruction of public highways or streets.
- 5.2. The Contractor shall provide and maintain all such guard lights and other protection for the public as may be required by applicable statutes, ordinances, and regulations or by local conditions.
- 5.3. The Contractor shall do all things necessary or expedient to protect properly any and all parallel, converging, and intersecting lines, joint line poles, highways, railways and any and all property of others from damage, and in the event that any such parallel, converging and intersecting lines, joint line poles, highways, railways or other property are damaged in the course of the construction of the line, the Contractor shall at his own expense immediately restore any or all of such damaged property to as good a state as before such damage occurred.
- 5.4. The Contractor shall enter and exit the right-of-way at those locations specified by Owner or the Engineer.

It shall be the responsibility of the Contractor to maintain safe and unobstructed control of traffic along all state roads, highways, and all other streets within the project area. The Contractor shall obtain sufficient and suitable traffic cones, barriers, warning signs, and other devices necessary to maintain a safe work environment for crews and the general public. Traffic control must be provided for in accordance with the Manual of Uniform Traffic Control Devices (MUTCD), the North Carolina Department of Transportation (NC D.O.T.) Supplement to the MUTCD, all local ordinances, and as approved by local and state authorities.

- 5.5. All ditches and access ways disturbed shall be returned to their pre-existing condition at the end of construction.
- 5.6. Any and all excess earth, rock, debris, underbrush, and other useless material shall be removed by the Contractor from the site of the work as rapidly as practicable as the work progresses.
- 5.7. Before beginning work in or around any areas where underground facilities are known to exist, the Contractor shall locate all such facilities including water, sewer, gas, telephone and electrical lines.

- 5.8. Upon violation by the Contractor of any provisions of this section, after written notice of such violation given to the Contractor by the Owner, the Contractor shall immediately correct such violation. Upon failure of the Contractor to do so, the Owner may correct such violation at the Contractor's expense.
- 5.9. The Contractor shall submit to the Owner monthly reports in duplicate of all accidents, giving such data as may be prescribed by the Owner.

6. SUPERVISION AND INSPECTION

- 6.1. The Contractor shall cause the construction work to receive constant supervision by a competent superintendent (hereinafter called the "Superintendent") who shall be present at all times during working hours where construction is being carried on. The Contractor shall also employ, in connection with the construction of the substation capable, experienced, and reliable foremen and such skilled workmen as may be required for the various classes of work to be performed. Directions and instructions given to the Superintendent by the Owner shall be binding upon the Contractor.
- 6.2. The Owner reserves the right to require the removal from the project of any employee of the Contractor if, in the judgment of the Owner, such removal shall be necessary in order to protect the interest of the Owner. The Owner shall have the right to require the Contractor to increase the number of his employees and to increase or change the amount or kind of tools and equipment if at any time the progress of the work shall be unsatisfactory to the Owner; the failure of the Owner to give any such directions shall not relieve the Contractor of his obligations to complete the work within the time and in the manner specified in this Proposal.
- 6.3. The manner of performance of the work, and all equipment used therein, shall be subject to the inspection, tests and approval of the Owner. The Contractor shall have an authorized agent accompany the Owner when final inspection is made and, if requested by the Owner, when any other inspection is made.
- 6.4. In the event that the Owner shall determine that the construction contains or may contain numerous defects, it shall be the duty of the Contractor, if requested by the Owner to have an inspection made by the Engineer for the purpose of determining the exact nature, extent, and location of such defects.

7. TEMPORARY CONSTRUCTION

All temporary construction required to accomplish the work covered in these Specifications shall be the sole responsibility of the Contractor. The Contractor shall furnish all labor and materials necessary for temporary construction including the installation and removal of structures, poles, insulators, hardware, guys, anchors, etc. All materials used for temporary construction shall be removed from the site as soon as practicable and the site restored to as good a state as before such construction. All temporary materials supplied by the Contractor will remain the property of the Contractor. All temporary construction shall be performed and shall adhere to the same safety and code requirements as the proposed work and shall be covered by all requirements of these Plans, Specifications, and Contract Documents.

No extra pay item will be issued for temporary construction, or for subsequent removal of same.

8. NORMAL WORK WEEK

- 8.1. The Contractor shall provide the Owner quoted prices on a per-hour basis, for various personnel and equipment, assuming a normal work week as being forty (40) hours.
- 8.2. The Contractor shall state in the Proposal his normal work week for the project.
- 8.3. Work on weekends or generally accepted holidays will only be allowed if specific outage arrangements are required or the Contractor falls behind in meeting the project's scheduled completion date.
- 8.4. The Contractor will not be paid for inclement weather days or for travel time to and from the job site, unless expressly requested by the Contractor as a written stipulation to his original Proposal.

9. JOB-SITE OBLIGATIONS

- 9.1. Except as otherwise provided in the Contract, necessary sanitary conveniences for use by the Contractor's employees and Subcontractors at the Jobsite shall be furnished and maintained by the Contractor in such manner and at such locations as shall be approved by the Company Representative and their use shall be strictly enforced.

- 9.2. The Contractor shall, at all times, keep its work areas in a neat, clean, and safe condition. The Contractor shall be responsible for continuous clean up and removal of its trash, debris, waste materials and scrap and disposal of same off the Jobsite. Upon completion of any portion of the Work, the Contractor shall immediately remove all its equipment, construction plant, temporary structures and surplus materials not to be used at or near the same location during later stages of the Work. Upon completion of the Work and before final payment is made, the Contractor shall, at its expense, satisfactorily dispose of all plant, buildings, rubbish, unused materials, and other equipment and materials belonging to it or used in the performance of the Work, including return to the Owner's warehouse or designated lay down area(s), at the Owner's option of any salvageable materials for which the Owner has reimbursed the Contractor or that has been supplied by the Owner for incorporation into the Work but not used; and the Contractor shall leave the premises in a neat, clean and safe condition acceptable to the Company Representative. In the event of the Contractor's failure to comply with the foregoing, the same may be accomplished by the Owner at the Contractor's expense.
- 9.3. The Owner reserves the right to authorize its agents or designees to enter the jobsite as it may elect for the purpose of inspecting the work or constructing or installing such collateral work as it may desire, or testing, boring or surveying, or any other purpose.
- 9.4. The Contractor understands and agrees that duly authorized representatives of government agencies having appropriate jurisdiction may enter the Jobsite at any time and from time to time.
- 9.5. If any Work or part thereof shall be covered contrary to the requirements of the Contract or the request of the Owner or Engineer, it must, if required by the Company Representative, be uncovered for observation and inspection and covered again at the Contractor's sole expense.
- 9.6. If any other Work that the Company Representative has not specifically requested to observe and inspect prior to being covered has been covered, the Owner or Engineer may request to see such Work or part thereof and it shall be uncovered by the Contractor. If such Work or part thereof is found to be in accordance with the Contract, the cost of uncovering and covering again shall, by appropriate Change Form, be charged to the Owner. If such Work or part thereof fails to meet the requirements of the Contract, the Contractor shall pay

all costs of uncovering, correcting, and covering again and any additional costs resulting there from.

- 9.7. The Contractor shall conduct daily and weekly on-site safety meetings at the beginning of each work period. These meetings should not preclude the Contractor from conducting tailgate safety meetings before each new work period, after break, different work assignments, etc. as determined by OSHA and other applicable safety laws and regulations. In addition, the Contractor shall be required to attend onsite safety meetings with the Owner.
- 9.8. All personnel / visitors / individuals shall have a safety briefing by the Contractor prior to entering the energized substation area.
- 9.9. The Contractor shall facilitate a formal safety program for all individuals entering the site.
- 9.10. The Contractor shall provide the Owner a copy of the Contractor's Safety Manual, outlining policies, procedures, documentation, and training. The Owner will provide the Contractor with a copy of the Owner's Safety Manual. The Contractor shall perform the work using the more stringent of the two policies.

CONTRACT AGREEMENT

THIS CONTRACT made this _____ day of _____, 2024, by _____, hereinafter called Bidder, and GREENVILLE UTILITIES COMMISSION (GUC) OF THE CITY OF GREENVILLE, PITT COUNTY, NORTH CAROLINA, a corporation, hereinafter called the Owner.

WITNESSETH

THAT WHEREAS, a Contract for

**GREENVILLE UTILITIES COMMISSION
RELOCATION OF 12.47 KV DISTRIBUTION AND 115 KV TRANSMISSION
STRUCTURES ALONG ALLEN ROAD**

has recently been awarded to Bidder by the Owner at and for a total price of _____ AND 00/100 (\$ _____) named in the Bidder's Proposal attached hereto;

AND WHEREAS, it was provided in said award that a formal Contract would be executed by and between Bidder and Owner, evidencing the terms of said award, and that Bidder would commence the work to be performed under this agreement on a date to be specified in a written order of Owner, and would fully complete all work thereunder no later than 348 days from the date of contract.

NOW, THEREFORE, Bidder doth hereby covenant and agree with Owner that it will well and faithfully perform and execute such work and furnish such work and furnish such materials and equipment in accordance with each and every one of the conditions, covenants, stipulations, terms, and provisions contained in said Specifications in accordance with the Plans, at the total price named therefore in the Bidder's Proposal attached hereto, and will well and faithfully comply with and perform each and every obligation imposed upon it by said Plans and Specifications and the terms of said award.

Bidder shall promptly make payments to all laborers and others employed thereon.

Bidder shall be responsible for all damages to the property of the owner that may be consequent upon the normal procedure of its work or that may be caused by or result from the negligence of Bidder, its employees, or agents during the progress of or connected with the prosecution of the work, whether within the limits of the work or elsewhere. Bidder must restore all property so injured to a condition as good as it was when Bidder entered upon the work.

By execution of this Contract, both parties acknowledge the following conditions as a part of their respective obligations:

- a) Governing Law – This Contract shall be construed and enforced in accordance with the laws of the State of North Carolina. All parties agree to the jurisdiction of the Courts of North Carolina with respect to an action or dispute arising between the parties.
- b) Further Assurances – The parties hereto agree to execute and deliver any and all papers and documents which may be necessary to carry out the terms of this Contract.
- c) Entire Contract – This Contract (including materials incorporated herein by reference) constitutes the entire agreement between the parties hereto and there are no agreements, representations, or warranties which are not set forth herein. All prior negotiations, agreements, and understandings are superseded hereby. This Contract may not be amended or revised except by a writing signed by all parties hereto. This Contract shall be construed and interpreted without any presumption either for or against the party who caused its preparation.
- d) Binding Effect – This Contract shall be binding upon an inure to the benefit of the heirs, legal representatives, successors and assigns of the respective parties hereto, provided that this Contract and all rights hereunder may not be assigned by any party hereto without the written consent of the other party.
- e) Time of Performance – Time is of the essence with regard to the performance of this Contract.
- f) Survivability – The terms of this Contract shall survive execution and delivery of any deeds or bills of sale called for hereunder.
- g) Headings – The headings in the paragraphs of this Contract are inserted for convenience only and do not constitute a part hereof.

Bidder shall furthermore be responsible for and required to make good at its expense any and all damages of whatever nature to persons or property arising during the period of the Contract caused by carelessness, neglect, or want of due precaution on the part of Bidder, its agents, employees, or workmen. Bidder shall also indemnify and save harmless the Owner, and the officers and agents thereof, from all third party claims, suits, and proceedings of every name and description which may be brought against the Owner, or the officers and agents thereof, for or on account of any injuries or damages to persons or property received or sustained by any person or persons, firm, or corporation, by or in consequence of any materials used in said work, to the extent caused by the negligence of Bidder, its agents, employees, servants, or workmen.

It is agreed and understood that the Notice to Prospective Bidders, Definitions, Instructions to Bidders, and Technical Specifications, the accepted Bidder's Proposal, and the enumerated addenda are incorporated in this Contract by reference and are an integral part thereof as set forth herein.

And the Owner doth hereby covenant and agree with Bidder that it will pay to Bidder, when due and payable under the terms of said Specifications and said award, the above-mentioned sum;

and that it will well and faithfully comply with and perform each and every obligation imposed upon it by said Specifications and the terms of said award.

Bidder shall, upon completion of all work awarded under this Contract, furnish to the Owner invoices or copies of invoices for all materials purchased for said work; and such invoices shall state the amount of North Carolina sales tax paid for said materials. Bidder shall also furnish the Owner and affidavit certifying the total costs of materials purchased for all work performed under the Contract and the total amount of state sales tax paid for said materials.

Whenever used herein, the singular shall include the plural, the plural the singular, and the use of any genders shall be applicable to all genders as the context may require.

[Balance of Page Left Blank Intentionally]

PROVIDE CURRENT LIABILITY INSURANCE CERTIFICATE(S)

Section I General Instructions, 24. Contractor's Insurance

COVERAGES:

1. Workmen's Compensation Insurance shall include all of the Bidder's employees employed at the site of the project under his contract. In case any class of employees engaged in hazardous work under this Contract at the site of the project is not protected under the Workmen's Compensation Statute, the Bidder shall provide adequate coverage for the protection of his employees not otherwise protected.
2. Public Liability and Property damage Insurance shall be in such amounts as to adequately protect the Owner and the Bidder from claims for damages for personal injury, including accidental death, as well as from claims for property damages which may arise from operations under this Contract, whether such operations be by himself or by anyone directly or indirectly employed by him. The amount of such insurance shall be for the following:
 - 2.1. Public Liability Insurance for bodily injury or death \$1,000,000 per one person, and \$2,000,000 for each accident.
 - 2.2. Property Damage Insurance \$2,000,000 for each accident and \$2,000,000 aggregate for accidents during the policy period.
3. Motor Vehicle Liability Insurance shall be for the following amounts:
 - 3.1. Bodily injury or death \$1,000,000 for one person and \$2,000,000 for each accident.
 - 3.2. Property damage is \$2,000,000 for each accident.

Copies of Certificates of Insurance for all aforementioned policies shall be furnished by the Bidder and shall be attached to the respective pages of the Contract Agreement at the time of signing.

It shall be understood that the above required insurance shall not be canceled or changed until thirty (30) days after written notice of such termination or alteration has been sent by registered mail to the certificate holder. Each certificate must not terminate before the contract completion date.

CERTIFICATE HOLDER:

Greenville Utilities Commission
401 South Green Street
Greenville, NC 27835-1847
Contact: Mr. Cleve Haddock, Lifetime CLGPO
Phone: 252-551-1533

IN TESTIMONE WHEREOF, Bidder and Owner have duly signed and sealed this Contract.

BIDDER:

(Imprint Corporate Seal
Below this line)

_____(SEAL)

By _____(SEAL)

Title _____

ATTEST:

By: _____

Title: _____

**GREENVILLE UTILITIES COMMISSION
(GUC) OF THE CITY OF GREENVILLE,
PITT COUNTY, NORTH CAROLINA**

By _____
Anthony C. Cannon

Title _____
General Manager/CEO

ATTEST:

By: _____
Amy Wade

Title: _____
Executive Secretary

APPROVED AS TO FORM AND LEGALITY:

By: _____
Phillip R. Dixon

Title: _____
General Counsel

CERTIFICATE OF ATTORNEY

**GREENVILLE UTILITIES COMMISSION (GUC)
OF THE CITY OF GREENVILLE,
PITT COUNTY, NORTH CAROLINA**

This is to certify I have examined the attached Contract Documents, and after such examination I am of the opinion that such Documents conform to the laws of the State of North Carolina, the execution of the Contract is in due and proper form, the representatives of the respective contracting parties have full power and authority to execute such contract on behalf of the respective contracting parties, and the foregoing agreements constitute valid and binding obligations on such parties.

By: _____
Phillip R. Dixon

Title: _____
General Counsel

Date: _____

**GREENVILLE UTILITIES COMMISSION
GREENVILLE, NORTH CAROLINA**

**STRUCTURE RELOCATION
CONTRACT FOR 12.47 KV DISTRIBUTION AND 115 KV TRANSMISSION
ALONG ALLEN ROAD**

**FORM OF PROPOSAL
(Provide two (2) copies)**

Respectfully submitted this _____ day of _____, 2024.

OWNER:	BIDDER
<p>Greenville Utilities Commission 401 South Greene Street Greenville, North Carolina 27834 P.O. Box 1847 Greenville, North Carolina 27835</p> <p>Mr. Cleve Haddock, Lifetime CLGPO Procurement Manager Office: 252-551-1533 Cell: 252-361-3655</p>	
	<p>NAME TITLE</p>
	<p>STREET ADDRESS</p>
	<p>CITY/STATE/ZIP</p>
	<p>PHONE:</p>
	<p>FAX:</p>
	<p>EMAIL:</p>
	<p>SIGNATURE</p>
<p align="center">MANUFACTURER OF PROPOSED EQUIPMENT</p>	
<p>MANUFACTURER</p>	
<p>STREET ADDRESS</p>	
<p>CITY/STATE/ZIP</p>	

TERMS AND CONDITIONS

1. The undersigned, hereafter called the Contractor, hereby declares that the only person or persons interested in this Proposal as principal or principals is or are named herein and that no other person than herein mentioned has any interest in this Proposal or in the Contract to be entered into; that this Proposal is made without connection with any other person, company or parties making a bid or Proposal; and that it is in all respects fair and in good faith without collusion or fraud.
2. The Contractor further declares that he has examined the site of the work and informed himself fully in regard to all conditions pertaining to the locations where the work is to be done; that he has examined the Technical Specifications for the work and Contract Documents relative there to, and has read all special provisions furnished prior to the opening of bids; that he has satisfied himself relative to the work to be performed.
3. The Contractor proposes and agrees, if this Proposal is accepted, to contract with the Owner in the form of Contract specified, to furnish all necessary labor, equipment, and materials, except materials and equipment specified to be furnished by the Owner, required for the installation of the station, complete in accordance with the Plans, Specifications and Contract Documents, to the full and entire satisfaction of the Owner with a definite understanding that no money will be allowed for extra work except as set forth in the General Conditions and Contract Documents, as filed on Change Order forms. No changes in work shall begin without prior written approval by the Owner or its representative Engineer.
4. The Bid Schedule is subject to the following terms and conditions which, by reference, are made a part of this Proposal.
5. The prices of materials set forth herein do not include any sums which are or may be payable by the Contractor on account of North Carolina Sales Tax upon the sale, purchase, or use of the materials hereunder, the amount thereof shall be added to the purchase price and paid by the Owner after the Contractor has ascertained the actual sales tax to be included in the Contract price.
6. The prices quoted in the Proposal shall be firm unless otherwise clearly noted in the Proposal.
7. The price quoted includes delivery FOB substation site of any equipment and materials and complete installation at substation site. The prices of the equipment and installation set forth herein shall include the cost of delivery at the Contractor's risk to the site.
8. The Contractor shall provide the Owner quoted prices on a per-hour basis, for various personnel and equipment, assuming a normal work week as being forty (40) hours.
9. The Contractor shall state his normal work week for the project:

_____ Five (5), eight (8) hour days (Monday through Friday)

_____ Four (4), ten (10) hour days (Monday through Thursday)

_____ Other, _____

10. Work on weekends or generally accepted holidays will only be allowed if specific outage arrangements are required, or if the Contractor falls behind in meeting the project's scheduled completion date. If the Contractor deems this necessary, he must receive the Owner's written approval five (5) business days prior to beginning the revised work scheme.
11. The time of completion for this project is of the essence.
12. The Contractor shall submit a proposed project construction schedule with the Proposal for review and approval by the Owner and Engineer. The targeted date for completion is June 7, 2025. If this date is not possible, please present an alternate date.
13. The time for delivery and installation shall be extended for the period of any reasonable delay due exclusively to causes beyond the control and without fault of the Contractor, including acts of God, fires, floods, strikes, and delay in transportation.
14. The Contractor will not be paid for inclement weather days or for travel time to and from the job site, unless expressly requested by the Contractor as a written stipulation to his original Proposal.
15. The Contractor-furnished materials shall conform to the "Technical Specifications" attached hereto and made a part hereof.
16. Title to the materials furnished by the Contractor shall pass to the Owner upon completion of the installation at the point above specified.
17. This Proposal is made pursuant to the provisions of the Notice and Instructions to Bidders, the Specifications, and the Contractor agrees to the terms and conditions thereof.
18. The Contractor warrants the accuracy of all statements contained in the Bidders Qualifications, if any shall be submitted, and agrees that the Owner shall rely upon such accuracy as a condition of the Contract if this Proposal is accepted.
19. The Contractor warrants that the Contractor-furnished Materials will conform to the performance data and guarantees attached which, by this reference, are made a part of this Proposal. Any exceptions or deviations from the Plans and Specifications must be clearly stated in the Proposal to warrant consideration.

20. The Contractor assumes liability for the proper care, handling, storage, and security of all materials furnished to the Contractor by the Owner for the project.
21. The undersigned further agrees that in case of failure on his part to execute said Contract within ten (10) consecutive calendar days after written notice has been given of the Award of the Contract, bid security accompanying this bid, and the monies payable thereon, shall be paid into the funds of the Owner's account set aside for this project, as liquidated damages for such failure, otherwise, the check, cash, or Original Bid Bond accompanying the Proposal shall be returned to the undersigned.
22. The Contractor shall maintain during the project and shall provide the Owner/Engineer one (1) complete set of "as-constructed" drawings upon the completion of the project.
23. The Contractor warrants that it possesses Electric Utility Contractor's License for the State of North Carolina. A copy of the license shall be included in this *Form of Proposal*.
24. The Contractor shall submit, in the *Form of Proposal*, the proposed project management staff, i.e., project manager, site superintendent, general foreman, etc. The qualifications / work experience level of the Bidder's proposed work force shall be included as well. The Contractor shall provide evidence of a minimum of 60% of the proposed work force having five (5) years or more tenure with the Bidder's firm. If other personnel are assigned to the project, similar information will be required prior to construction assignment.
25. The Contractor shall provide a list of recent projects of similar voltage class and complexity, along with the Owner and contact information of the representative who was reported to directly.
26. If the proposed staff along with their qualifications is not provided, the bid may be subject to non-compliance, thus, making it unacceptable.
27. The Contractor shall provide a list of subcontractors (if any) in the proposal and their respective support services which will be used by the Contractor when undertaking this project. All subcontractors will be subject to review and approval by the Owner.
28. **A mandatory pre-construction meeting will be scheduled at a later time based on the construction schedule.**
29. Uniform Guidance: Contracts funded with federal grant or loan funds must be procured in a manner that conforms with all applicable federal laws, policies, and standards, including those under the Uniform Guidance (2 C.F.R. Part 200).

INSERT

ADDENDA / CLARIFICATIONS / BULLETINS

Section I General Instructions, 6. Bulletins and Addenda

PROPOSAL PAGES

DISTRIBUTION AND TRANSMISSION CONSTRUCTION ASSEMBLY UNITS

Definitions:

POLE UNITS

A pole unit consists of one pole in place. It does not include pole-top construction assembly unit or other parts attached to the pole. The first two digits of the unit number column indicate the length of the pole; the following digits specify the RUS Class.

Pole Plan Under Which the Poles are to be Furnished: (Check one)

1. Insured Warranted
2. Independently Inspected
3. Quality Assured
4. Either Insured Warranted, Independently Inspected, or quality Assured

POLE TOP CONSTRUCTION ASSEMBLY UNITS

A pole top construction assembly unit generally consists of the insulator(s), crossarm(s), braces, and hardware, except tie wire, required to support the power conductors and overhead ground wire, as indicated on the applicable drawing. It does not include the pole, the downlead, and butt coil, which are separate units.

GUY CONSTRUCTION ASSEMBLY UNITS (DG UNITS)

A guy construction assembly unit consists of the hardware and wire. Guy guards are designated separately.

ANCHOR CONSTRUCTION ASSEMBLY UNITS

An anchor construction assembly unit consists of the anchor with rod or rods, complete, ready for attaching the guy wire.

TRANSMISSION CONSTRUCTION ASSEMBLY UNITS CONTINUED

Definitions:

POLE UNITS

A pole unit consists of setting new pole top section of VC foundation, jacking slip joint, and installing pole ground and includes any temporary work needed for construction access around existing wires.

A mobilization and de-mobilization unit for vibratory hammer, cranes, and transmission bucket trucks shall be listed as separate unit price.

The existing pole VC foundation and pole top removal shall be listed as a transmission removal cost.

Final pole vendor drawings will be available prior to final pole and VC delivery, currently scheduled for December 2024.

POLE TOP CONSTRUCTION ASSEMBLY UNITS

Consists of installing new 115 kV insulators, hardware, OHGW hardware to new pole and reconnecting existing 115 kV conductors and OHGW to new pole and checking sag/tension to confirm insulators and clamps stay plumb. Includes any temporary work needed for construction access around existing wires.

All distribution underbuild unit descriptions will be as per distribution pole top units described in above section and per bid unit sheet.

FOUNDATION UNIT

Consists of vibratory steel casing installed in the ground to correct depth and alignment. Includes any temporary work needed for construction access around existing wires. Soil data from the old steel pole location, Boring #3 is attached for contractor reference in the transmission drawing attachments.

DISTRIBUTION CONSTRUCTION ASSEMBLY UNITS

Part 1a - Pole Units - Direct Embedded			Labor	
Unit NO.	Embedded Depth (FT)	NO. of Units	Unit Labor \$	Extended Labor \$
35 Foot Class 5 Pole	5.5	12	\$	\$
40 Foot Class 4 Pole	6	3	\$	\$
45 Foot Class 4 Pole	6.5	3	\$	\$
50 Foot Class 3 Pole	7	29	\$	\$
55 Foot Class 3 Pole	7.5	16	\$	\$
60 Foot Class 2 Pole	8	10	\$	\$
65 Foot Class 2 Pole	8.5	4	\$	\$
Install Pole Tag		77	\$	\$

Part 1b - Conductor Units		Labor	
Unit NO.	NO. of Units (FT)	Unit Labor \$	Extended Labor \$
#6 Aluminum Triplex (Poly)	359	\$	\$
#2 Aluminum Triplex (Clam)	1070	\$	\$
1/0 Aluminum Triplex (Murex)	488	\$	\$
2/0 Aluminum Triplex (Rucina)	467	\$	\$
1/0 Aluminum Clad Steel Reinforced (Raven) (Per Phase)	12238	\$	\$
336MCM Aluminum Clad Steel Reinforced (Merlin) (Per Phase)	28783	\$	\$
795MCM Stranded Aluminum (Arbutus) (Per Phase)	3156	\$	\$

Part 1c - Pole Framing Units		Labor	
Drawing NO.	NO. of Units	Unit Labor \$	Extended Labor \$
Single Phase Single Dead End (Tap), Suspension (A5)	5	\$	\$
Single Phase Tangent, Double Deadend Suspension (A6)	1	\$	\$
Two Phase Single Deadend (Tap), Suspension (B5)	1	\$	\$
Three Phase Tangent, MIF Construction Single Pin (C1)	15	\$	\$
Three Phase, Tangent, MIF Vertical Single Pin (C1.V1)	14	\$	\$
Three Phase Small Angle, MIF Construction Double Pin (C2)	15	\$	\$
Three Phase Large Angle, Suspension Insulator (C3)	5	\$	\$
Three Phase Large Angle, Double Deadend Suspension (C4)	15	\$	\$
Three Phase Single Deadend, Crossarm Suspension (C5)	8	\$	\$
Three Phase Single Deadend (Tap), Vertical Suspension (C5.V)	5	\$	\$
Three Phase Tangent Double Deadend, Cross Suspension (C6)	2	\$	\$
Three Phase Tangent, Double Deadend Suspension (C6.V)	3	\$	\$

Part 1d - Guy Construction Units		Labor	
Drawing NO.	NO. of Units	Unit Labor \$	Extended Labor \$
DG-12_14	201	\$	\$
SWG-12_14	9	\$	\$
DG-SG	44	\$	\$

Part 1e - Anchor Construction Units		Labor	
Drawing NO.	NO. of Units	Unit Labor \$	Extended Labor \$
DA	122	\$	\$

DISTRIBUTION CONSTRUCTION ASSEMBLY UNITS CONTINUED

Part 1f - Transformer Units		Labor	
Unit NO.	NO. of Units	Unit Labor \$	Extended Labor \$
Single Phase Transformer, 10 kVA CSP (120/240)	4	\$	\$
Single Phase Transformer, 15 kVA CSP (120/240)	11	\$	\$
Single Phase Transformer, 25 kVA CSP (120/240)	4	\$	\$
Three Phase Transformer Bank, (3) 50 kVA Conventional (120/240)	1	\$	\$

Part 1g - Protection & Sectionalizing Units		Labor	
Unit NO.	NO. of Units	Unit Labor \$	Extended Labor \$
Fused Cutout - Single Phase	4	\$	\$
Fused Cutout - Two Phase	1	\$	\$
Fused Cutout - Three Phase	10	\$	\$
600A Inline Switches - Three Phase	4	\$	\$
900A Horizontal Gang Switch- Three Phase	3	\$	\$
600A Vertical Gang Switch-Three Phase	2	\$	\$

Part 1h - Riser Pole (OH to UG)		Labor	
Unit NO.	NO. of Units	Unit Labor \$	Extended Labor \$
Single Phase 200A w/ Fused Cutout	2	\$	\$
Two Phase 200A w/ Fused Cutout	1	\$	\$
Three Phase 200A w/ Fused Cutout	6	\$	\$

Part 1i - Voltage Alteration Units		Labor	
Unit NO.	NO. of Units	Unit Labor \$	Extended Labor \$
Capacitor Bank (Three Phase)	2	\$	\$

Part 1j - Secondary Service Units		Labor	
Unit NO.	NO. of Units	Unit Labor \$	Extended Labor \$
Connect Service On Pole	3	\$	\$
Service Assembly - Secondary Riser Up Pole	9	\$	\$
Light Fixture Installation	6	\$	\$

Part 2a - Excavation Units		Labor	
Unit NO.	NO. of Units (FT)	Unit Labor \$	Extended Labor \$
Machine Trench (minimum 40" cover)	5	\$	\$
Backhoe (minimum 24" cover)	405	\$	\$
Backhoe (minimum 40" cover)	258	\$	\$
Reseed Trench	1336	\$	\$

Part 2b - Boring Units		Labor	
Unit NO.	NO. of Units (FT)	Unit Labor \$	Extended Labor \$
2" Directional Boring (1 conduit)	672	\$	\$
3" Directional Boring (1 conduit)	104	\$	\$
4" Directional Boring (1 conduit)	1504	\$	\$

DISTRIBUTION CONSTRUCTION ASSEMBLY UNITS CONTINUED

Part 2c - Conduit Installation (In Trench) Units		Labor	
Unit NO.	NO. of Units	Unit Labor \$	Extended Labor \$
2" Conduit	935	\$	\$
3" Conduit	123	\$	\$
4" Conduit	1663	\$	\$
5" Conduit	5	\$	\$
2" PVC 90* Elbow	11	\$	\$
2" PVC 45* Elbow	5	\$	\$
3" PVC 90* Elbow	3	\$	\$
3" PVC 45* Elbow	1	\$	\$
4" PVC 90* Elbow	8	\$	\$
4" PVC 90* Elbow (36" RAD)	2	\$	\$
4" PVC 45* Elbow	2	\$	\$
5" PVC 90* Elbow	2	\$	\$

Part 2d - UG Primary In Conduit Installation Units		Labor	
Unit NO.	NO. of Units (FT)	Unit Labor \$	Extended Labor \$
1/0 AWG Aluminum(1 Phase)	6438	\$	\$

Part 2e - UG Secondary In Conduit Installation Units		Labor	
Unit NO.	NO. of Units (FT)	Unit Labor \$	Extended Labor \$
#6 Aluminum Triplex	893	\$	\$
2/0 Aluminum Triplex	360	\$	\$
4/0 Aluminum Triplex	115	\$	\$
350 Aluminum Triplex	104	\$	\$

Part 2f - Pandmounted Transformers & Equipment		Labor	
Unit NO.	NO. of Units	Unit Labor \$	Extended Labor \$
Two Phase Sectionalizing Cabinet	1	\$	\$
Three Phase Sectionalizing Cabinet	1	\$	\$
200A Load Break Elbow	15	\$	\$
Bushing Inserts	6	\$	\$
10 kV Elbow Arrestor	3	\$	\$
200A Terminator	19	\$	\$

Part 2g - Secondary Pedestal/Service		Labor	
Unit NO.	NO. of Units	Unit Labor \$	Extended Labor \$
9x14 Pedestal	4	\$	\$
9x14 Pedestal Flat Lid	4	\$	\$
18x24 Pedestal	2	\$	\$
18x24 Pedestal Flat Lid	2	\$	\$
4 Point Secondary Buss Kit	5	\$	\$
Connect Service in Pedestal or Transformer	5	\$	\$
Connect Service in Meter Base	4	\$	\$

TRANSMISSION CONSTRUCTION ASSEMBLY UNITS

Part 3a - Transmission Pole Units		Labor	
Unit NO.	NO. of Units	Unit Labor \$	Extended Labor \$
105 ft tangent Valmont V13 pole , 8700 lbs, 35.16 base dia, 14.7" top dia	1	\$	\$
tapered VC fnd, 25 ft embed, 7 ft tapered reveal, 32 ft long , 5400 lbs	1	\$	\$
S-3B framing, 115kv HLP susp, 1 OHGW susp	1	\$	\$
DC UB on FG crossarm	3	\$	\$
SC UB on 35 kv line posts	1	\$	\$
Mob and De mob for crews and specialty equipment, VC, cranes, buckets	1	\$	\$
Pole 42 and foundations removal and wire transfer	1	\$	\$

[Balance of Page Left Blank Intentionally]

PROPOSAL SUMMARY

DISTRIBUTION AND TRANSMISSION CONSTRUCTION ASSEMBLY UNITS

Distribution Removal	\$ _____
Transmission Removal	\$ _____
Wood Pole Install.....	\$ _____
Tubular Steel Pole Install	\$ _____
Distribution Pole Top Assembly.....	\$ _____
Transmission Pole Top Assembly.....	\$ _____
Guy Assembly.....	\$ _____
Anchor Assembly.....	\$ _____
Conductor Assembly.....	\$ _____
OH/UG Service Units.....	\$ _____

TOTAL CONSTRUCTION ASSEMBLY UNITS \$ _____

INSERT

PROPOSED CONSTRUCTION SCHEDULE

*General Instructions, 19. Completion
Terms and Conditions – Item 12*

INSERT

CERTIFICATE(S) OF INSURANCE

General Instructions, 24. Contractor's Insurance

INSERT

CONTRACTOR'S LICENSE

*General Instructions, 25. Contractor's License
Terms and Conditions – Item 23*

EQUAL EMPLOYMENT OPPORTUNITY AFFIDAVIT
General Conditions, 24. Equal Employment Opportunity

The Contractor shall include the provisions of the Equal Employment Opportunity, as found in General Conditions section, in every Subcontract unless exempted by rules, regulations, or orders of the Owner so that such provisions will be binding upon each Subcontractor.

Bidder: _____

By: _____

Date: _____

Special Instructions to Bidders

**City of Greenville/Greenville Utilities Commission
Minority and/or Women Business Enterprise (M/WBE) Program**

**GUC
Construction Guidelines and Affidavits
\$100,000 and above**

These instructions shall be included with each bid solicitation.

**City of Greenville/Greenville Utilities Commission
Minority and/or Women Business Enterprise Program**

\$100,000 and Construction Guidelines for M/WBE Participants

Policy Statement

It is the policy of the City of Greenville and Greenville Utilities Commission to provide minorities and women equal opportunity for participating in all aspects of the City’s and Utilities’ contracting and procurement programs, including but not limited to, construction projects, supplies and materials purchases, and professional and personal service contracts.

Goals and Good Faith Efforts

Bidders responding to this solicitation shall comply with the M/WBE program by making Good Faith Efforts to achieve the following aspiration goals for participation.

	GUC	
	MBE	WBE
Construction This Goal includes Construction Manager at Risk	7%	4%

Bidders shall submit M/WBE information with their bids on the forms provided. This information will be subject to verification by GUC prior to contract award. **As of July 1, 2009, contractors, subcontractors, suppliers, service providers, or M/WBE members of joint ventures intended to satisfy GUC M/WBE goals shall be certified by the NC Office of Historically Underutilized Businesses (NC HUB) only.** Firms qualifying as “WBE” for GUC’s goals must be designated as a “women-owned business” by the HUB Office. Firms qualifying as “MBE” for GUC’s goals must be certified in one of the other categories (i.e.: Black, Hispanic, Asian American, American Indian, Disabled, or Socially and Economically Disadvantaged). Those firms who are certified as both a “WBE” and “MBE” may only satisfy the “MBE” requirement. A complete database of NC HUB certified firms may be found at <http://www.doa.nc.gov/hun/>. An internal database of firms who have expressed interest to do business with the City and GUC is available at www.greenvillencmwbe.org. However, the HUB status of these firms must be verified by the HUB database. GUC shall accept NCDOT certified firms on federally funded projects only. Please note: A contractor may utilize any firm desired. However, for participation purposes, all M/WBE vendors who wish to do business as a minority, or a female must be certified by NC HUB.

The Bidder shall make good faith efforts to encourage participation of M/WBEs prior to submission of bids in order to be considered as a responsive bidder. Bidders are cautioned that even though their submittal indicates they will meet the M/WBE goal, they should document their good faith efforts and be prepared to submit this information, if requested.

The M/WBE's listed by the Contractor on the **Identification of Minority/Women Business Participation** which are determined by the GUC to be certified shall perform the work and supply the materials for which they are listed unless the Contractors receive prior authorization

from the GUC to perform the work with other forces or to obtain materials from other sources. If a contractor is proposing to perform all elements of the work with his own forces, he must be prepared to document evidence satisfactory to the owner of similar government contracts where he has self-performed.

The Contractor shall enter into and supply copies of fully executed subcontracts with each M/WBE or supply signed Letter(s) of Intent to the Project Manager after award of contract and prior to Notice to Proceed. Any amendments to subcontracts shall be submitted to the Project Manager prior to execution.

Instructions

The Bidders Shall Provide with the bid the following documentation:

- Identification of Minority/Women Business Participation
(if participation is zero, please mark zero – Blank forms will be considered nonresponsive)
- Affidavit A (if subcontracting)

OR

- Identification of Minority/Women Business Participation
(if participation is zero, please mark zero – Blank forms will be considered nonresponsive)
- Affidavit B (if self-performing; must attest that bidder does not customarily subcontract work on this type of project – includes supplies and materials)

Within 72 hours or 3 business days after notification of being the apparent low bidder who is subcontracting anything must provide the following information:

- Affidavit C (if aspirational goals are met or are exceeded)

OR

- Affidavit D (if aspirational goals are not met)

After award of contract and prior to issuance of notice to proceed:

- Letter(s) of Intent or Executed Contracts

****With each pay request, the prime contractors will submit the Proof of Payment Certification, listing payments made to M/WBE subcontractors.**

*****If a change is needed in M/WBE Participation, submit a Request to Change M/WBE Participation Form. Good Faith Efforts to substitute with another M/WBE contractor must be demonstrated.**

Minimum Compliance Requirements:

All written statements, affidavits, or intentions made by the Bidder shall become a part of the agreement between the Contractor and the GUC for performance of contracts. Failure to comply with any of these statements, affidavits or intentions or with the minority business guidelines shall constitute a breach of the contract. A finding by the GUC that any information submitted (either prior to award of the contract or during the performance of the contract) is inaccurate, false, or incomplete, shall also constitute a breach of the contract. Any such breach may result in termination of the contract in accordance with the termination provisions contained in the contract. It shall be solely at the option of the GUC whether to terminate the contract for breach or not. In determining whether a contractor has made Good Faith Efforts, the GUC will evaluate all efforts made by the Contractor and will determine compliance regarding quantity, intensity, and results of these efforts.

Greenville Utilities Commission AFFIDAVIT A – Listing of Good Faith Efforts

County of _____

Affidavit of _____

(Name of Bidder)

I have made a good faith effort to comply under the following areas checked:

Bidders must earn at least 50 points from the good faith efforts listed for their bid to be considered responsive. (1 NC Administrative Code 30 I.0101)

- 1 – (10 pts)** Contacted minority businesses that reasonably could have been expected to submit a quote and that were known to the contractor, or available on State or local government-maintained lists, at least 10 days before the bid date and notified them of the nature and scope of the work to be performed.
- 2 – (10 pts)** Made the construction plans, specifications and requirements available for review for review by prospective minority businesses or providing these documents to them at least 10 days before the bids are due.
- 3 – (15 pts)** Broken down or combined elements of work into economically feasible units to facilitate minority participation.
- 4 – (10 pts)** Worked with minority trade, community, or contractor organizations identified by the Office of Historically Underutilized Businesses and included in the bid documents that provide assistance in recruitment of minority businesses.
- 5 – (10 pts)** Attended Prebid meetings scheduled by the public owner.
- 6 – (20 pts)** Provided assistance in getting required bonding or insurance or provided alternatives to bonding or insurance for subcontractors.
- 7 – (15 pts)** Negotiated in good faith with interested minority businesses and did not reject them as unqualified without sound reasons based on their capabilities. Any rejection of a minority business based on lack of qualification should have the reasons documented in writing.
- 8 – (25 pts)** Provided assistance to an otherwise qualified minority business in need of equipment, loan capital, lines of credit, or joint pay agreements to secure loans, supplies, or letters of credit, including waiving credit that is ordinarily required. Assisted minority businesses in obtaining the same unit pricing with the bidder's suppliers in order to help minority businesses in establishing credit.

9 – (20 pts) Negotiated joint venture and partnership arrangements with minority businesses in order to increase opportunities for minority business participation on a public construction or repair project when possible.

10 – (20 pts) Provided quick pay agreements and policies to enable minority contractors and suppliers to meet cash-flow demands.

The undersigned, if apparent low bidder, will enter into a formal agreement with the firms listed in the identification of Minority/Women Business Participation schedule conditional upon scope of contract to be executed with the Owner. Substitution of contractors must be in accordance with GS143-128.2(d). Failure to abide by this statutory provision will constitute a breach of the contract.

The undersigned hereby certifies that he or she has read the terms of the minority/women business commitment and is authorized to bind the bidder to the commitment herein set forth.

Date: _____ Name of Authorized Officer: _____

Signature: _____

Title: _____

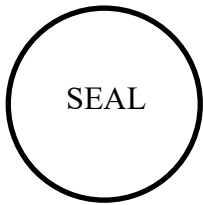

State of _____, County of _____

Subscribed and sworn to before me this _____ day of _____ 20____

Notary Public _____

My Commission expires _____

Greenville Utilities Commission - AFFIDAVIT B - Intent to Perform Contract with Own Workforce

County of _____

Affidavit of _____
(Name of Bidder)

In making this certification, the Bidder states that the Bidder does not customarily subcontract elements of this type of project, and normally performs and has the capability to perform and will perform all elements of the work on this project with his/her own current work forces; and

The Bidder agrees to provide any additional information or documentation requested by the owner in support of the above statement.

The undersigned hereby certifies that he or she has read this certification and is authorized to bind the Bidder to the commitments herein contained.

Date: _____ Name of Authorized Officer: _____

Signature: _____

Title: _____



State of _____, County of _____

Subscribed and sworn to before me this _____ day of _____ 20_____

Notary Public _____

My commission expires _____

Greenville Utilities Commission – AFFIDAVIT C – Portion of the Work to be Performed by M/WBE Firms

County of _____

(Note this form is to be submitted only by the apparent lowest responsible, responsive bidder.)

If the portion of the work to be executed by M/WBE businesses as defined in GS143-128.2(g) and the COG/GUC M/WBE Plan sec. III is equal to or greater than 11% of the bidder’s total contract price, then the bidder must complete this affidavit. This affidavit shall be provided by the apparent lowest responsible, responsive bidder within **72 hours** after notification.

Affidavit of _____ I do hereby certify that on the
(Name of Bidder)

(Project Name)

Project ID# _____ Amount of Bid \$ _____

I will expend a minimum of _____% of the total dollar amount of the contract with minority business enterprises and a minimum of _____% of the total dollar amount of the contract with women business enterprises. Minority/women businesses will be employed a construction subcontractors, vendors, suppliers, or providers of professional services. Such work will be subcontracted to the following firms listed below.

Name and Phone Number	*M/WBE Category	Work Description	Dollar Value

*M/WBE categories: Black, African American (**B**), Hispanic, Latino (**L**), Asian American (**A**), American Indian (**I**), Female (**F**), Socially and Economically Disadvantaged (**S**), Disabled (**D**)

Pursuant to GS143-128.2(d), the undersigned will enter into a formal agreement with M/WBE Firms for work listed in this schedule conditional upon execution of a contract with the Owner. Failure to fulfill this commitment may constitute a breach of the contract.

The undersigned hereby certifies that he or she has read the terms of this commitment and is authorized to bind the bidder to the commitment herein set forth.

Date: _____ Name of Authorized Officer: _____

Signature: _____

Title: _____

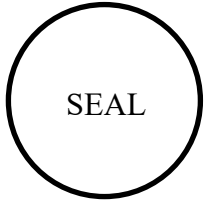

State of _____, County of _____

Subscribed and sworn to before me this _____ day of _____ 20_____

Notary Public _____

My commission expires _____

Greenville Utilities Commission – AFFIDAVIT D – Good Faith Efforts

County of _____

(Note this form is to be submitted only by the apparent lowest responsible, responsive bidder)

If the goal of 11% participation by minority/women business **is not** achieved, the Bidder shall provide the following documentation to the Owner of his good faith efforts:

Affidavit of _____ I do hereby certify that on the
(Name of Bidder)

_____ (Project Name)

Project ID# _____ Amount of Bid \$ _____

I will expend a minimum of _____% of the total dollar amount of the contract with minority business enterprises and a minimum of _____% of the total dollar amount of the contract with women business enterprises. Minority/women businesses will be employed a construction subcontractors, vendors, suppliers, or providers of professional services. Such work will be subcontracted to the following firms listed below.

Name and Phone Number	*M/WBE Category	Work Description	Dollar Value

*M/WBE categories: Black, African American (**B**), Hispanic, Latino (**L**), Asian American (**A**), American Indian (**I**), Female (**F**), Socially and Economically Disadvantaged (**S**), Disabled (**D**)

Examples of documentation required to demonstrate the Bidder's good faith efforts to meet the goals set forth in these provisions include, but are not necessarily limited to, the following:

- A. Copies of solicitations for quotes to at least three (3) minority business firms from the source list provided by the State for each subcontract to be let under this contract (if 3 or more firms are shown on the source list). Each solicitation shall contain a specific description of the work to be subcontracted, location where bid documents can be reviewed, representative of the Prime Bidder to contact, and location, date and time when quotes must be received.
- B. Copies of quotes or responses received from each firm responding to the solicitation.
- C. A telephone log of follow-up calls to each firm sent a solicitation.
- D. For subcontracts where a minority business firm is not considered the lowest responsible, responsive sub-bidder, copies of quotes received from all firms submitting quotes for that subcontract.

- E. Documentation of any contacts or correspondence to minority business, community, or contractor organizations in an attempt to meet the goal.
- F. Copy of pre-bid roster.
- G. Letter documenting efforts to provide assistance in obtaining required bonding or insurance for minority business.
- H. Letter detailing reasons for rejection of minority business due to lack of qualification.
- I. Letter documenting proposed assistance offered to minority business in need of equipment, loan capital, lines of credit, or joint pay agreements to secure loans, supplies, or letter of credit, including waiving credit that is ordinarily required.

Failure to provide the documentation as listed in these provisions may result in rejection of the bid and award to the next lowest responsible and responsive bidder

Pursuant to GS143-128.2(d), the undersigned will enter into a formal agreement with M/WBE Firms for work listed in this schedule conditional upon execution of a contract with the Owner. Failure to fulfill this commitment may constitute a breach of the contract.

The undersigned hereby certifies that he or she has read the terms of this commitment and is authorized to bind the bidder to the commitment herein set forth.

Date: _____ Name of Authorized Officer: _____

Signature: _____

Title: _____

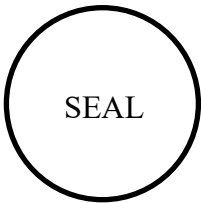

State of _____, County of _____

Subscribed and sworn to before me this _____ day of _____ 20____

Notary Public _____

My commission expires _____

**LETTER OF INTENT
M/WBE Subcontractor Performance**

Please submit this form or executed subcontracts with M/WBE firms after award of contract and prior to issuance of notice to proceed.

PROJECT: _____
(Project Name)

TO: _____
(Name of Prime Bidder/Architect)

The undersigned intends to perform work in connection with the above project as a:

_____ Minority Business Enterprise _____ Women Business Enterprise

The M/WBE status of the undersigned is certified by the NC Office of Historically Underutilized Businesses (required). _____ Yes _____ No

The Undersigned is prepared to perform the following described work or provide materials or services in connection with the above project at the following dollar amount:

Work/Materials/Service Provided	Dollar Amount of Contract	Projected Start Date	Projected End Date

(Date)

(Address)

(Name & Phone No. of M/WBE Firm)

(Name & Title of Authorized Representative of M/WBE)

(Signature of Authorized Representative of M/WBE)

REQUEST TO CHANGE M/WBE PARTICIPATION

Submit changes only if notified as apparent lowest bidder, continuing through project completion)

Project: _____

Bidder or Prime Contractor: _____

Name & Title of Authorized Representative: _____

Address: _____ **Phone #:** _____

_____ **Email Address:** _____

Total Contract Amount (including approved change orders or amendments): \$ _____

Name of Subcontractor: _____

Good or service provided: _____

Proposed Action:

- _____ Replace subcontractor
- _____ Perform work with own forces

For the above actions, you must provide one of the following reasons (Please check applicable reason):

_____ The listed MBE/WBE, after having had a reasonable opportunity to do so, fails or refuses to execute a written contract.

_____ The listed MBE/WBE is bankrupt or insolvent.

_____ The listed MBW/WBE fails or refuses to perform his/her subcontract or furnish the listed materials.

_____ The work performed by the listed subcontractor is unsatisfactory according to industry standards and is not in accordance with the plans and specifications; or the subcontractor is substantially delaying or disrupting the progress of the work.

Proof of Payment Certification
M/WBE Contractors, Suppliers, Service Providers

Project Name: _____ Pay Application No. _____

Prime Contractor: _____ Purchase Order No. _____

Current Contract Amount (including change orders): \$ _____

Requested Payment Amount for this Period: \$ _____

Is this the final payment? Yes No

Firm Name	*M/WBE Category	Total Amount Paid from this Pay Request	Total Contract Amount (including changes)	Total Amount Remaining

*M/WBE categories: Black, African American (**B**), Hispanic, Latino (**L**), Asian American (**A**), American Indian (**I**), Female (**F**), Socially and Economically Disadvantaged (**S**), Disabled (**D**)

Date: _____

Certified By: _____

Name

Title

Signature

PROPOSED PROJECT MANAGEMENT STAFF

Terms and Conditions – Item 24

Title/Function	Name	Years with Firm	Total Years Experience
Project Manager			
Site Superintendent			
General Foreman - Foundations			

CONTRACTOR HAS DOES NOT HAVE SIXTY PERCENT (60%) OF PROPOSED WORK FORCE WITH FIVE (5) YEARS CONTINUOUS SERVICE WITH BIDDER'S FIRM

REFERENCES

Terms and Conditions – Item 25

CONTACT INFORMATION FOR RECENT SIMILAR PROJECTS

Owner Name	Project Description	Contact Name and Phone Number

LIST OF SUBCONTRACTORS
Terms and Conditions – Item 27

SUBCONTRACTOR	PROPOSED WORK TO BE PERFORMED

E-VERIFY LETTER OF COMPLIANCE

1. I have submitted a proposal for contract or desire to enter into a contract with the Greenville Utilities Commission;
2. As part of my duties and responsibilities pursuant to said proposal and/or contract, I affirm that I am aware of and in compliance with the requirements of E-Verify, Article 2 of Chapter 64 of the North Carolina General Statutes, to include (mark which applies):
3. ____ After hiring an employee to work in the United States I verify the work authorization of said employee through E-Verify and retain the record of the verification of work authorization while the employee is employed and for one year thereafter; or
4. ____ I employ less than twenty-five (25) employees in the State of North Carolina.
5. As part of my duties and responsibilities pursuant to said proposal and/or contract, I affirm that to the best of my knowledge and subcontractors employed as a part of this proposal and/or contract, are in compliance with the requirements of E-Verify, Article 2 of Chapter 64 of the North Carolina General Statutes, to include (mark which applies):
6. ____ After hiring an employee to work in the United States the subcontractor verifies the work authorization of said employee through E-Verify and retains the record of the verification of work authorization while the employee is employed and for one year thereafter; or
7. ____ Employ less than twenty-five (25) employees in the State of North Carolina.
Specify subcontractor: _____

_____ (Company Name)

By: _____ (Typed Name)

_____ (Authorized Signatory)

_____ (Title)

_____ (Date)

**LETTER OF COMPLIANCE TO THE
IRAN DIVESTMENT ACT CERTIFICATION**

Name of Vendor or Bidder: _____

**IRAN DIVESTMENT ACT CERTIFICATION
REQUIRED BY N.C.G.S. 143C-6A-5(a)**

As of the date listed below, the vendor or bidder listed above is not listed on the Final Divestment List created by the State Treasurer pursuant to N.C.G.S. 143-6A-4.

The undersigned hereby certifies that he or she is authorized by the vendor or bidder listed above to make the foregoing statement.

Signature Date

Printed Name Title

BID BOND

KNOW ALL MEN BY THESE PRESENT, THAT WE _____

_____ as Principal, and _____ as Surety, who is duly licensed to act as Surety in North Carolina, are held and firmly bound unto the Greenville Utilities Commission, Greenville, NC, as Obligee, in the penal sum of _____ DOLLARS (\$ _____) (5% Bid Bond), lawful money of the United States of America, for the payment of which, well and truly to be made, we bind ourselves, our heirs, administrators, successors and assigns, jointly and severally, firmly by these present.

SIGNED, Sealed and dated this _____ day of _____, 2024.

WHEREAS, the said Principal is herewith submitting a Proposal for

**DISTRIBUTION AND TRANSMISSION STRUCTURE RELOCATION
ALONG ALLEN ROAD**

and the Principal desires to file this Original Bid Bond in Lieu of making the cash deposit as required by the bidding documents contained herein;

NOW, THEREFORE, THE CONDITION OF THE ABOVE OBLIGATION is such that if the principal shall be awarded the Purchase Order for which the bid is submitted and shall accept the Purchase Order within ten (10) days after the award of same to the principal, then this obligation shall be null and void; but if the principal fails to so accept such purchase order as required by the bidding documents contained herein, the Surety shall, upon demand, forthwith pay to the Obligee the amount set forth in the first paragraph hereof, and upon failure to forthwith make such payment, the Surety shall pay the Obligee an amount equal to double the amount of this Bid Bond as set forth in the first paragraph hereof. Power of Attorney from the surety to is Attorney-in-Fact is attached hereto.

Principal

By _____(SEAL)

Corporate Surety

By _____(SEAL)

PERFORMANCE BOND/PAYMENT BOND

Date of Execution: _____

Name of Principal: _____

(Contractor) _____

Name of Surety: _____

Name of Contracting
Body: _____

Amount of Bond: _____

Project: _____

KNOW ALL THESE MEN BY THESE PRESENT, That We, the Principal and Surety above named, are held and firmly bound unto the above named Contracting Body, hereinafter called the Contracting Body, in the penal sum of the amount stated above the payment of which sum well and truly to be made, we bind ourselves, our heirs, executors, administrators, and successors, jointly and severally, firmly by these present.

THE CONDITION OF THIS OBLIGATION IS SUCH that whereas the Principal entered into a certain Contract with the Contracting Body, identified as shown above and hereto attached.

NOW, THEREFORE, if the Principal shall well and truly perform and fulfill all the undertakings, covenants, terms, conditions, and agreements of said Contract during the original term of said Contract and any extensions there of that may be granted by the Contracting Body, with or without notice to the Surety, and during the life of any guaranty required under the Contract, and shall also well and truly perform and fulfill all the undertakings, covenants, terms, conditions, and agreements of any and all duly authorized modifications of said Contract that may hereafter be made, notice of which modifications to the Surety being hereby waived, then, this obligation to be void; otherwise to remain in full force and virtue.

IN WITNESS WHEREOF, the above bounded parties have executed this instrument under the several seals on the date indicated above, the name and corporate seal of each corporate party being hereto affixed, and these present duly signed by its undersigned representative, pursuant to authority of its governing body.

Executed in five (5) counterparts.

Witness:

CONTRACTOR:

(Proprietorship or Partnership)

(Trade or Corporate Name)

ATTEST:

By: _____

By: _____

Title: _____
(Corporate Secretary or
Assistant Secretary Only)

Title: _____

(CORPORATE SEAL)

Witness:

SURETY COMPANY:

Countersigned:

By: _____

Title: _____
(Attorney-in-Fact)

N.C. Licensed Resident Agent

(Name and Address – Surety Agent)

(SURETY SEAL)

Surety Company Name and N.C.
Regional or Branch Office Address

***SPACE FOR ATTACHING POWER OF ATTORNEY
(Performance Bond)***

SECTION II

GREENVILLE UTILITIES COMMISSION

TECHNICAL SPECIFICATIONS INSTALLATION SPECIFICATIONS

May 30, 2024

1. SCOPE

This Specification covers the installation, removal, transfers, and materials of 77 distribution structures and 1 transmission structure along Allen Road. The new distribution line will be built behind the existing line to allow for DOT road widening. The existing structures will be removed. All transfers are the responsibility of the contractor. New primary and secondary conductors will be pulled. Existing transmission conductors will be transferred. All hardware and insulators will be replaced. Fiber and telecommunication transfers shall also be included. The proposal submitted by the contractor shall include all labor, equipment, and all other necessary items to complete this project.

The distribution primary overhead conductor installations consist of approximately 3,100 feet of 795 AAC, 29,000 feet of 336 ACSR, and 12,200 feet of 1/0 ACSR measured in linear feet per phase.

The distribution primary underground conductor installations consist of approximately 6,400 feet of 1/0 AWG Aluminum measured in linear feet per phase.

The transmission conductor being transferred is 1272 kcmil 61/0 strands NARCISSUS AAC.

Stantonsburg Road and Allen Road intersection shall be the priority to begin relocations. Therefore, relocation work on Detail Construction Drawing "Sheet#: 14" shall be completed as first order of business and prior to beginning other construction relocations.

Transmission pole delivery is planned for December 2024. Change orders will not be accepted for transmission pole delivery delays.

Distribution parcels with outstanding easements will not be available for construction relocation prior to verbal or written authorization from engineering. Parcels with outstanding distribution easements are expected to be acquired no later than October 15, 2024. All distribution parcels with outstanding easements are depicted with red identification numbers on the Detail Construction Drawings and are identified as followed: 18Z, 24Z, 28Z, 64Z.

2. GENERAL

- 2.1. The new construction, rearrangements, relocations, modifications, and removals shall be complete in accordance with the Plans, Specifications, stringing charts,

and Assembly Drawings. All work shall be done in a thorough and workmanlike manner.

- 2.2. The latest edition of the National Electrical Safety Code shall be followed. All construction shall conform to that required for a medium loading district. Deviations from the Plans, Specifications, and Construction Drawings will not be permitted except upon written permission from the Engineer.
- 2.3. All work shall be done in a thorough and workmanlike manner to produce a complete and functional system with minimal interruption to customers served by existing facilities.

3. CODES AND STANDARDS

Codes, standards, or other documents referred to in this specification shall be considered as part of this specification. The following codes and standards are referenced:

- 3.1. American Institute of Steel Construction (AISC), *Specification for the Design, Fabrication and Erection of Structural Steel for Buildings*, latest edition.
- 3.2. American Society of Civil Engineers (ASCE) Standard, *Design of Steel Transmission Pole Structures*, Manual 48, latest edition.
- 3.3. American Society for Testing and Materials (ASTM), various standards, latest version.
- 3.4. American Concrete Institute (ACI), *Building Code Requirements for Reinforced Concrete*, ACI 318, latest edition.
- 3.5. American Welding Society (AWS), *Structural Welding Code*, AWS D1.1, latest edition.
- 3.6. American National Standards Institute (ANSI), *National Electrical Safety Code*, ANSI C2, latest edition.
- 3.7. Society for Protective Coatings (SSPC, formerly Steel Structure Painting Council), *Surface Preparation Specification*, SSPC SP6/NACE NO.3, latest edition.

4. REMOVALS

- 4.1. Removals shall consist of removing each and every item designated on the drawings, the disassembling of structures into material items, and the transportation of the items from the site of the work to the storage area designated by the Commission.

- 4.2. Poles with telecommunication attachments shall be topped at the highest attachment. Poles without telecommunication attachments shall be removed.
- 4.3. Conductor removal shall include the coiling or reeling of the conductor removed in a workmanlike manner.
- 4.4. Anchor assemblies shall be removed by removing the anchor rod only. If the anchor rod cannot be unscrewed, the rod must be cut or bent down so as to be a minimum of eighteen inches (18") below the ground line. Screw-type anchors shall be completely removed.
- 4.5. The removal shall include any necessary handling, re-sagging, and retying of conductors in those cases where an existing assembly unit will be removed and replaced by a new assembly unit and where any existing conductor is to be retained. Removal will also include any holding or handling of main line or tap conductors at tap lines, angles, and deadends where such is involved and the reinstalling of such conductor, including re-sagging and reconnection. It shall also include reinstalling any conductors temporarily detached.
- 4.6. The Contractor shall reinstall, at his own expense, any other items removed by him for his own convenience.
- 4.7. Wood poles shall be cut into sections no longer than 45 feet in length and transported to the wood pole disposal area designated by the Commission.
- 4.8. All materials removed as part of the work and not specified to be reused will remain the property of the Commission.

5. TRANSFERRING

- 5.1. Transferring shall consist of disconnecting existing material and reinstalling this material in a different location on the same structure or a new structure, provided the new structure is adjacent to the existing structure.
- 5.2. The transfer shall include any necessary handling, re-sagging, and retying of all conductors in those cases where an existing assembly unit will be removed and replaced by a new assembly unit and where any existing conductor is to be retained. Transfer will also include any holding or handling of all conductors at tap lines, angles, and deadends where such is involved and the reinstalling of such conductor, including re-sagging and reconnection. It shall also include reinstalling any conductors temporarily detached.
- 5.3. Contractor will be responsible for all service transfers.

6. POLES-WOOD AND/OR TUBULAR STEEL

6.1. Inspection

- 6.1.1. All main-line distribution poles will be wood.
- 6.1.2. The Contractor shall not install a pole that, in his opinion, or the opinion of the Commission or Engineer, has been damaged or is otherwise unsafe. The Contractor shall promptly report any damaged or questionable pole or other component to the Commission and Engineer and confirm the report in writing.

6.2. Handling and Storage

- 6.2.1. The Contractor will be responsible for any damage to the poles and arms resulting from his handling, transporting, or storing procedures.
- 6.2.2. Poles and structural members' arms shall not be stored directly on the ground. Stored poles and arms shall be elevated from the ground using wood or other suitable non-abrasive blocking. Poles are to be stored with identification marks clearly visible.

6.3. Lifting and Setting

- 6.3.1. All poles shall be lifted in accordance with such precaution required to eliminate the possibility of bending or overstressing any section. Nylon slings shall be used to avoid damage to pole finish. During lifting, all flexible components shall be restrained to prevent any damage to insulators or pole finish.

- 6.3.2. The minimum setting depths shall be as follows:

<u>Pole Length</u> (Feet)	<u>Setting Depth</u> (Feet)
30	5.5
35	6.0
40	6.0
45	6.5
50	7.0
55	7.5
60	8.0
65	8.5
70	9.0
75	9.5
80	10.0
85	10.5
90	11.0
95	11.5

Additional embedment may be required for some construction units

- 6.3.3. On sloping ground, the depth of the hole shall always be measured from the low side of the hole.
- 6.3.4. Holes shall be approximately eight inches (8") larger than the butt diameter of the pole unless noted otherwise and shall be at least as large at the bottom as at the top.
- 6.3.5. All poles shall be set plumb and in alignment except at line angle points. At line angles where horizontal post insulators are stacked on one side of the pole or suspension insulator construction is used, poles shall be offset on the bisector of the angle so that conductors will hang directly over the point of intersection in line with the tangent in both directions. All poles shall be plumb after conductors are strung. Where poles are set along the edge of cuts or embankments, or where the soil is liable to be washed out, special precautions shall be taken to ensure durable foundations and the setting depth shall be measured from the lower side of the hole.

6.4. Excavation and Backfill

- 6.4.1. Unsuitable Material: The Contractor shall excavate for the foundation to the dimensions and outline shown on the Drawings. Excavated material which conforms to the Specifications for backfill material may be used for this purpose. Materials which are not suitable for backfill and excess material shall be disposed of as directed by the Commission or Engineer.
- 6.4.2. Excavation Classification: All excavation will be classified as "common excavation." All excavation including soft shale, gravel, or other material which can be removed by hand or machine is defined as common excavation.
- 6.4.3. Excavation Preparation: Excavation in earth shall be to clean level surfaces of undisturbed material of adequate bearing value. Over-excavation shall be backfilled with well compacted six-inch (6") layers of aggregate base course (ABC) gravel. If the over-excavation is unnecessary, the cost of the backfill shall be borne by the Contractor. The quality of the soil and the adequacy of its bearing value shall be decided by the Engineer before backfill material is placed in any excavation. Where water is encountered, the excavation shall be kept dry by pumping during the installation of the structure and during the backfilling process. If unsuitable material is encountered at the proposed bearing surface, the Engineer may require further excavation

to reach sound bearing. Backfill labor and material for this type of required over-excavation will be supplied at the Contractor's expense and should be included in the Unit Price for "M-2 (Stone Backfill)" in the Proposal Section. The Contractor will be paid on a per cubic yard unit basis.

- 6.4.4. Gravel Base: The stone or gravel base cited in Section 6.4.3 shall consist of a mixture of graded aggregate, coarse and fine, together with soil binder. The coarse aggregate shall consist of sound, tough, durable particles or fragments of gravel or stone. The material shall be placed in six-inch (6") layers and thoroughly compacted. A gravel base shall be formed before pole is placed in the excavated hole.
- 6.4.5. Excavation Maintenance: The excavation shall be maintained in a safe, clean and sound condition up to the time of placement of pole. The excavation shall be suitably protected when not attended. Whenever necessary, the Contractor shall re-excavate materials which have accumulated in the previously prepared excavation. Any muck or other unsatisfactory bearing material resulting from frost action or entrance of water into excavation previously prepared to the required depth for sound bearing shall be removed and replaced with well compacted ABC gravel backfill at the Contractor's expense.
- 6.4.6. Sheeting and Shoring: The Contractor shall do all bracing, sheeting, and shoring necessary to support and protect all excavations as required for safety and to conform to laws and regulations of all governmental bodies having jurisdiction. When sheeting is used, it shall be removed during or upon completion of backfilling.
- 6.4.7. Backfill: All backfill around the pole base shall be compacted in six-inch (6") layers by means of mechanical tampers. Excavated material is suitable for backfill, the Contractor shall at his expense spread and aerate the material around the structure after the excavation has been completely backfilled with the specified material. The surplus earth shall be placed around the pole in a conical shape and packed tightly in order that water will drain away from the pole. The degree of compaction to be attained for all backfill shall be the equivalent density of adjacent undisturbed earth. Large stones, muck, frozen material, roots, or other undesirable material shall not be used for backfilling. This material, furnished by the Contractor, shall be locally available and when placed and compacted in six-inch (6") layers will bind and compact around the foundation. Sources of this material shall be approved by the Engineer.

6.5. Holes in Pole

The Contractor will be responsible for field drilling distribution, fiber attachments, or any other holes required for construction (see drawings for details). Cost for drilling these holes shall be part of the pole top assembly unit. In no instances will additional charges be paid for drilling holes.

7. ROCK ENCOUNTERED DURING EXCAVATIONS

- 7.1. The Contractor shall be responsible for the removal and disposition of solid rock when encountered in holes for wood poles and tubular steel poles. Solid rock shall be defined as solid, naturally occurring mineral formations that cannot be effectively removed by conventional trenchers, backhoes, or pressure augers on line-trucks. Loose rock or limestone in intermittent layers that result in “difficult digging” shall not be defined as solid rock excavations. “Solid rock” shall require the use of air hammers, blasting or other specialized equipment. (Note: Blasting must be approved by the Commission in accordance with local ordinances.)
- 7.2. An adder (M-1 (Rockhole)) will be quoted by the Bidder in the Proposal Section to establish a labor cost for rock excavations, including disposition to the Commission’s landfill, on a per- cubic-yard basis. Quantities will be agreed upon jointly by the Contractor and the Commission (or Engineer) as the excavations occur. Over excavation to remove rock will not be counted in the quantity of rock excavations. The volume of rock excavation adder will be computed based on the normal pole hole diameter and depth, as if no rock were encountered. Rock adders will not apply to man-made surface treatments, such as asphalt, concrete or gravel.

8. DAVIT ARMS (*NOT APPLICABLE TO THIS PROJECT*)

Davit arms are being used on some structures for this project. The arms and all attachment hardware are being supplied by the steel pole manufacturer. It will be the Contractor’s responsibility to install the davit arms and ensure proper orientation of the arms.

9. GUYS AND ANCHORS

- 9.1. Guys shall be attachment type utilizing preformed guy grips or Strandvises. Guys shall be installed in locations specified by the Engineer. Points of attachment to poles shall be as shown on Construction Drawings. Guys shall be installed before conductors or overhead ground wires are strung.
- 9.2. All anchors and rods shall be in line with the strain. All anchors are to be single or multiple helix screw type or expanding rock type and shall be located as staked by the Engineer. Anchor rods shall be so installed that approximately six

inches (6") of the rod shall remain out of the ground or extend more than twelve inches (12") out of the ground in cultivated fields. The setting of each anchor in regard to depth, torque, and position shall be inspected by the Commission's Construction representative and his approval given in writing. The Contractor shall fill out anchor installation reports, furnished by the Engineer, as each anchor is installed. No anchor installations shall be invoiced without copies of the installation reports properly filled out and attached.

- 9.3. All anchors shall be installed using a Hydraulic Torque Indicator control tool. Expanding rock type anchors shall be installed and torqued per manufacturer's recommendations.
- 9.4. Anchor locations shall be checked and verified by the Contractor prior to installation to assure that guys do not conflict with phase conductors. This is especially critical when transmission guying passes through distribution phase positions. Where fiberglass guy strain insulators are installed in guys, a minimum of ten inches (10") must be maintained to any under-build phase conductors.
- 9.5. Where multiple fiberglass guy strain insulators are to be installed, in one (1) guy strand, they shall be connected using a chain link of the appropriate size.

10. HARDWARE

- 10.1. Hardware shall be installed as indicated on the Drawings. All bolts shall be installed with nuts and locknuts. Bolts shall be long enough to accommodate the necessary nuts, washers, etc. without projecting more than one and one-half inches (1-1/2") or less than one-half inch (1/2") at the free end. They shall not project more than one-fourth inch (1/4") into an eye-nut installed.
- 10.2. Care should be exercised during all phases of construction to protect all bolt threads. Nuts should operate on bolt threads without forcing.

11. INSULATORS

- 11.1. Care shall be exercised in handling and erecting insulators.
- 11.2. All insulators shall be handled with utmost care during storage, transportation, assembly, and installation. Care shall be taken to avoid bending stresses in insulator strings during handling. Insulators shall not be dropped. Insulators subjected to these or any other abuses or damage shall be permanently marked, rejected from the job and charged to the Contractor.
- 11.3. All insulators shall be protected from the accumulation of all foreign materials insofar as is possible. Mud, grease, and other foreign materials shall be cleaned from insulators using clean rags. Wire brushes may not be used for the cleaning

of any insulator parts. Upon installation, all insulators shall be clean on all surfaces. Workmen shall not climb on insulators at any time.

12. GROUNDING ASSEMBLY

12.1. Wood Poles

12.1.1. Driven ground rods (DM-9) shall be installed on all wood distribution poles as indicated on the Staking Sheets.

12.1.2. Refer to the following drawing for the grounding of wood distribution poles: DM-9

12.2. Where transmission and distribution assemblies are joint use structures, a common ground shall be shared. For wood poles, the common ground will be a ground wire. For steel poles, the common ground will be the pole itself.

12.3. Guys and overhead ground wires shall be attached to the common ground.

12.4. The distribution neutral shall be attached to the common ground.

12.5. Ground rods shall be driven to their full length into undisturbed earth according to the unit assembly drawings. The top of the ground rod shall be located a minimum of one foot (1'-0") below grade or as indicated otherwise on the Assembly Drawings.

12.6. Ground rods shall be 1-5/8" x 8'-0" and 1-5/8" x 12'-0" Copper. Extensions (DM-9) shall be added if necessary, to obtain a verifiable ground resistance of twenty-five (25) ohms or less.

12.7. Ground wire for distribution poles shall be No.4 AWG soft drawn tinned copper wire.

13. CONDUCTORS

13.1. Distribution Conductors

13.1.1. Care shall be exercised to avoid kinking, twisting, or abrading the conductor in any manner. Conductors shall not be trampled on, run over by vehicles, or dragged over sharp rocks. The wire on each reel shall be inspected for cuts, kinks, or other injuries. Injured portions or crooked or imperfect splices in the conductor shall be cut out and the wire respliced.

13.1.2. Conductors shall be pulled over suitable rollers or stringing blocks properly mounted on the pole or crossarm to prevent binding while stringing.

- 13.1.3. Installation of conductors and accessories shall be done in accordance with manufacturer's recommendations.
- 13.1.4. With post- and pin-type insulators, the conductors shall be tied in the top groove of the insulator on tangent poles and on the side of the insulator away from the strain at angles greater than ten degrees (10°). Post- and pin-type insulators shall be tight on the pins and on tangent construction the top groove must be in line with the conductor after tying in
- 13.1.5. There shall not be more than one splice per conductor in any span and no splice shall be located within ten feet (10'-0") of the conductor support. Splices will not be permitted in road or street crossing spans.
- 13.1.6. Utmost care shall be exercised in installing parallel groove clamps. The contact surface of the conductor shall be clean and bright. A steel brush shall be the principal cleaning medium; contact compound shall be used for all connections to aluminum conductors. Those same precautions for cleaning shall also apply to the conductor before splicing.
- 13.1.7. Conductors shall be sagged in accordance with sag and tension charts or tables furnished by the Engineer. Under no circumstances will a decrease in the specified sag be allowed. Sagging by sighting between targets or dynamometer is recommended.
- 13.1.8. The conductor temperature at the time and place of stringing shall be determined by a certified, thermometer inserted in a short section of conductor. The temperature at which the conductor is sagged and the spans in which sags are measured shall be recorded and the information given to the Engineer.

14. RIGHT OF WAY GENERAL

- 14.1. Access to right-of-way areas shall be from existing public or private roads or along existing Commission rights-of-way. Where private roads or trails are used, the Contractor shall obtain permission in writing from the property owner for their use with copies to be furnished to the Commission's Engineer.
- 14.2. All right-of-way clearing shall be completed for a section of the line before pole setting may begin. No poles shall be set with right-of-way not completely cleared.
- 14.3. All right-of-way clearing will be by the Commission.

14.4. At the completion of construction and clean-up, the Contractor shall regrade all disturbed right-of-way areas to their preconstruction contours where practicable. All cuts or fills shall maintain a maximum slope of 3:1 in order to insure as little run off as possible. Any soil erosion and sedimentation devices required to stabilize and/or reduce further erosion shall be installed. All devices installed during construction and no longer required shall be removed. All disturbed or denuded areas shall be covered with topsoil, if required, fertilized, limed, seeded, strawed, and tacked as necessary. Fertilizer, lime, and seed rates and mixes shall be as specified by the local soil conservation service for the time of year applied. All cost for right-of-way clean-up and restoration shall be included in the overall price of the project.

14.5. Maintenance of Existing Rights-of-Way

Existing rights-of-way, both public and private, must be maintained during construction in such a manner so as not to create a hazard. Deep ruts shall be backfilled and graded out. Denuded grass and vegetation areas shall be replanted with a suitable seed mixture. At the end of the construction, the right-of-way should be left in as good or better condition than it was before construction began. All cost of maintaining existing right-of-way and/or reseeding shall be borne by the Contractor.

14.6. Temporary Service or Access Roads

14.6.1. If, during the course of construction, it should become necessary for the Contractor to construct, modify, widen, grade, or perform any other earth work in order to provide access to or work areas around any facilities covered in this Contract, he shall do so at his own cost.

14.6.2. The Contractor shall be responsible for all permits required for such construction. He shall also be responsible for the installation and maintenance of any soil erosion and sediment control devices required by local, county, or state agencies.

14.6.3. All cost associated with the construction, maintenance, removal, and rehabilitation of any area associated with the rights-of-way, access roads, service roads, etc., shall be included in the Contractor's overall price. A separate cost item will not be billed for this work.

14.7. Poles & Foundations in Wetlands

14.7.1. Any excavation for poles and/or foundations in wetland areas shall utilize extra precaution to avoid disturbing the root mat around the excavated area. Tree stumps and root mats must be left intact in forested wetlands.

- 14.7.2. Any excess excavated soil in wetland areas must be removed from the wetland area and deposited (spread evenly) on higher ground.
- 14.7.3. No concrete may be poured directly in wetland areas. The use of steel vibratory casings/forms must be used to prevent contact of concrete with surface waters. The cost of the casing/form must be included in the foundation unit.
- 14.7.4. No mechanized clearing (bulldozers) in jurisdictional wetlands.
- 14.7.5. Minimize soil disturbance in jurisdictional wetlands (use mats where possible).
- 14.7.6. Maintain preconstruction contours in jurisdictional wetlands.

[Balance of Page Left Blank Intentionally]

SECTION III

GREENVILLE UTILITIES COMMISSION

TECHNICAL SPECIFICATIONS-MATERIALS SPECIFICATIONS

May 30, 2024

1. SCOPE

All hardware, conductors, and insulators needed to complete each structure will be replaced. Greenville Utilities Commission will furnish all distribution materials required for the construction unless otherwise noted in this specification. The proposal submitted by the contractor shall include all labor, equipment, and all other necessary items to complete this project.

2. GENERAL

- 2.1. All materials shall be new, except items specified for reuse, and will be furnished by the Commission and the Contractor as outlined in this specification.
- 2.2. All materials issued to the Contractor must be acknowledged by a material receipt.
- 2.3. Materials removed and salvaged must be returned to the Commission's warehouse and a receipt will be issued to the Contractor for materials returned.
- 2.4. The Contractor will be charged for all materials removed which are neither reused nor returned to the Commission's warehouse. Current stock item prices will be used to determine the removed material charge.
- 2.5. A brief description of the materials is furnished hereinafter for the Contractor's information.
- 2.6. Reference to ASTM, NEMA, AWS, SSPC, or ACI Standard implies reference to the latest revision or to its replacement if it has been discontinued.

3. POLES-WOOD-

- 3.1. All poles shall meet the requirements of ANSI Standard "Specifications and Dimensions for Wood Poles 05.1," the latest revision thereof.
- 3.2. Poles shall be framed as indicated on the Drawings. All holes shall be field drilled and treated with a two percent (2%) solution of Copper Naphthenate or other EPA approved preservative before framing.

- 3.3. New poles shall be Southern Yellow Pine or Douglas Fir and shall meet the requirements set forth in ANSI Specification and Dimensions for Wood Poles 05.1. Treatment shall be AWP Standard C4 for the Preservative Treatment of Poles by Waterborne Process. The preservative shall be Chromated Copper Arsenate, CCA, conforming to AWP Specification P5, or the latest revisions thereof.

4. POLES-TUBULAR STEEL- *Furnished by Owner*

- 4.1. All poles will meet the requirements of the Tubular Steel Structures Specifications pertaining to this project.
- 4.2. Transmission and distribution under-build pole-top assembly attachment point holes will be predrilled at the factory, unless otherwise specified. The contractor will be responsible for field drilling any other holes required for construction. Cost for drilling these holes shall be part of the pole top assembly unit. In no instance will additional charges be paid for drilling holes. The Contractor shall touch up the finish of all field drilled holes using high zinc content paint (Galvon) supplied by the pole manufacturer.
- 4.3. Poles may be delivered in two (2) or three (3) pieces. The Contractor is responsible for all field assembly required for these poles. Additionally, the Contractor is responsible for providing any equipment (i.e., jacks) required to join pieces.
- 4.4. Any unused holes are to be plugged and sealed using galvanized steel plugs or caulk and plastic plugs.

5. HARDWARE-*Furnished by Owner*

Hardware shall be hot dip galvanized.

- 5.1. Bolts and nuts shall conform to ANSI Standards as follows:
 - 5.1.1. C135.1 for machine, carriage, and double-arming bolts
 - 5.1.2. C135.4 for eye bolts
 - 5.1.3. C135.3 for lag screws
- 5.2. Steel parts shall conform to ASTM Specifications A36.
- 5.3. Malleable iron shall conform to ASTM Specifications A47.
- 5.4. Galvanizing shall conform to ASTM Specifications A153.

6. GUY WIRE-*Furnished by Owner*

Guy wire shall be 3/8” High Strength Steel rated 10,800 pounds ultimate strength and supplied by the Owner.

7. OVERHEAD GROUND WIRE-*Not Applicable to this Project*

A 7 No. 9 Alumoweld overhead ground wire shall be installed.

8. ANCHORS-*Furnished by Owner*

- 8.1. Distribution anchors shall be a no wrench 96” long with a single 10” helix. Anchors have a tripeye and are rated 10,000 lbs. in Class 6 soil.
- 8.2. The anchors shall be installed per the manufacturer’s recommendations.
- 8.3. The ultimate holding capacity of these anchors is dependent upon the soil properties. Holding capacity for Class 6 soil is 10,000 lbs.
- 8.4. The holding capacity of the anchors is dependent upon the torque values achieved while setting the anchors. Additionally, it will be necessary for the eye of the anchor to be installed a specific distance out of the ground in accordance with the construction drawings.

In order for the Contractor to meet the specification criteria for both torque and depth, it may be necessary to use multiple shaft length extensions in increments of three and one- half feet (3’-6”), and six feet (6’-0”).

9. INSULATORS-*Furnished by Owner*

9.1. Suspension

9.1.1. Insulators shall be polymer and shall conform to ANSI, IEEE, ASTM, and AEIC Standards for insulators. All suspension insulators shall be gray.

9.1.2.

Insulator Type	Flashover (kV)		Leakage (in.)	Suggested Manufacturer	Catalog Number
	Dry	Wet			
Polymer Suspension	155	135	31	Ohio Brass	4010250215

9.1.3. Suspension insulators shall be attached via shoulder eye through bolts, or guy plates.

9.2. Horizontal Post

9.2.1. Porcelain 15 kV Pin insulators shall be Porcelain products or equivalent.

9.2.2.

Insulator Type	Flashover (kV)		Leakage (in.)	Suggested Manufacturer	Catalog Number
	Dry	Wet			
Porcelain 15 kV Pin	55	30	7	Porcelain Products	263-S

9.2.3. Mechanical strength 2500 lbs, design cantilever load.

10. FIBERGLASS STRAIN INSULATOR-Furnished by Owner

Fiberglass strain insulator for use in guys shall have an ultimate strength of 16,000 pounds; shall have an insulating distance of thirty-six inches (36") and shall be equipped with clevis ends and the number of rollers required.

11. CONNECTORS AND SPLICES-Furnished by Owner

All connectors and splices for 1272 AAC, 795 AAC, 556 ACSR, 336 ACSR, 1/0 ACSR, and 7 No. 9 Alumoweld OHGW conductors shall be the compression type. Full tension compression splices shall develop strength equal to not less than ninety-five percent (95%) of the ASTM rated strength of the conductor. See Material List and Cross Reference pages provided by Greenville Utilities Commission for preferred manufacturer and catalog numbers.

12. ARMOR RODS-Furnished by Owner

Where armor rods are installed on phase conductors or OHGW, they shall be of a type specifically designed for the conductor being protected and shall be manufactured with aluminum alloy, aluminized acceptable. Armor rods shall be installed with the midpoint within two inches (2") of the center of the suspension clamp. The maximum distance between the ends of any two (2) individual rods within a bundle shall not exceed one-half inch (1/2").

13. CONDUCTOR CLAMPS-Furnished by Owner

13.1. Trunnion Clamps and Suspension Clamps

Suspension clamps and connecting pieces, material items on tangent and light/medium angle type pole top assemblies for 1272 AAC, 795 AAC, 556 ACSR, 336 ACSR, 1/0 ACSR, and 7 No. 9 Alumoweld OHGW conductors shall be sized to fit conductor with Armor Rod as manufactured by Preformed or approved equal. See Material List and Cross Reference pages provided by

Greenville Utilities Commission for preferred manufacturer and catalog numbers.

13.2. Cushion Grip Supports

Cushion grip supports on tangent and light/medium angle type pole top assemblies shall be sized to fit 1272 AAC, 795 AAC, 556 ACSR, 336 ACSR, 1/0 ACSR, and 7 No. 9 Alumoweld OHGW conductors. See Material List and Cross Reference pages provided by Greenville Utilities Commission for preferred manufacturer and catalog numbers.

14. DEADENDS-*Furnished by Owner*

Deadends for 1272 AAC, 795 AAC, 556 ACSR, 336 ACSR, 1/0 ACSR, and 7 No. 9 Alumoweld OHGW conductors may be bolted, quadrant type or full compression. See Material List and Cross Reference pages provided by Greenville Utilities Commission for preferred manufacturer and catalog numbers.

15. GROUNDING-*Furnished by Owner*

- 15.1. All poles shall have driven grounds as indicated on the Drawings. Guys and overhead ground wire shall be attached to the common ground.
- 15.2. Ground rods shall be 5/8" x 8' and 5/8" x 12' copper. Extensions shall be added if necessary, to obtain a verifiable ground resistance of 25 ohms or less. Ground rods shall be installed at the direction of the Engineer. Threaded ground rod couplings shall be used to secure each ground rod section as it is installed.
- 15.3. Ground wire for poles shall be No. 4 AWG soft drawn tinned copper wire unless otherwise specified.

16. STATIC GROUND BRACKETS-*Not Applicable to this Project*

The ground wire cable supports shall be Hughes Brothers 2855 series or approved equal for tangent and light angle structures.

17. CONDUCTOR-

- 17.1. Overhead conductor for the distribution line is 336 kcmil ACSR. The neutral conductor is 1/0 ACSR.
- 17.2. Overhead Service conductors consist of 2/0, 1/0, #2, and #6 triplex.

18. OWNER-FURNISHED MATERIAL STANDARDS*-Furnished by Owner*

The successful bidder will be provided a list of Owner-furnished material pages as a "Standard" for reference. The Commission may substitute other manufacturer's products of equal or better quality.

[Balance of Page Left Blank Intentionally]

Appendix A: Detail Construction Drawings

[Balance of Page Left Blank Intentionally]

LEGEND	
	INSTALL (RED)
	REMOVE (GREEN)
	EXISTING TO REMAIN (BLUE)
	ABANDON (ORANGE)
	TEMPORARY (YELLOW)
	PERMANENT UTILITIES EASEMENT
	AERIAL UTILITIES EASEMENT

REMOVALS:	OH INSTALLATIONS:	UG INSTALLATIONS:
POLES: 35: 1 40: 4 45: 3 50: 1 55: 1	POLES: 35C: 1 40C: 2 50C: 1 55C: 2 60C: 3 TAGS: 9	EXCAVATION: BACKHOE(24"): 19' RESEED: 38' BORING: BORE(1-3"): 104' CONDUIT: 3" COND: 123' 3" 90° ELBOW: 3 3" 45° ELBOW: 1 LG SECONDARY: 4.0 TPK: 15' 350 TPK: 104' LG SECONDARY SVC: SVC IN METER: 2
OH CONDUCTORS: #2 TPK: 317' 1/0 ACSR: 714' 3/6 ACSR: 2142' OH MISC: DOWN GUY: 17 SPAN GUY: 4 ANCHORS: 2 10 FRAMING: 1 30 FRAMING: 9 30 FUSE: 1 GANG SW: 2 TRANSFORMERS: 15kVA CSP TFO: 1 25kVA CSP TFO: 1 30 BANK 150kVA (120/208): 1 UNDERGROUND: 4.0 TPK: 134' 350 TPK: 111' REMOVE SVC: 2	OH CONDUCTORS: #2 TPK: 151' 1/0 ACSR: 522' 3/6 ACSR: 1566' FRAMING: CI.VI: 4 C4: 2 C5.V: 2 C6.V: 1 BS: 1 DOWN GUYS: 25 SPAN GUYS: 10 ANCHORS: 13 TRANSFORMERS: 10kVA CSP TFO: 1 15kVA CSP TFO: 1 25kVA CSP TFO: 1 30 BANK 150kVA (120/208): 1 PROTECTION: 30 FUSE: 1 900A HORIZ. GANG SW: 1 600A VERT. GANG SW: 1 SECONDARY SVC: SEC. RISER: 2	

DETAIL CONSTRUCTION DRAWING	
Site Contact: James Richardson	Phone Number: (919) 612-9716
Site Contact: Danny Cobb	Phone Number: (919) 654-5874
GUC Contact: Jacob Swink	Phone Number: (252) 508-6891
GUC Contact:	Phone Number:
Address: U-5875 Allen Rd 4000 Dickinson Ave Greenville, NC 27834	Scale: 1" = 50' Sheet #: 4

PIKE ENGINEERING
4721 HARGROVE ROAD
RALEIGH, NC 27616
LICENSURE #: F-1217

ISSUED FOR CONSTRUCTION

VERIFY PHASING AT TIME OF CONSTRUCTION.
PHASING ON PRINT IS BASED ON RECORDS.

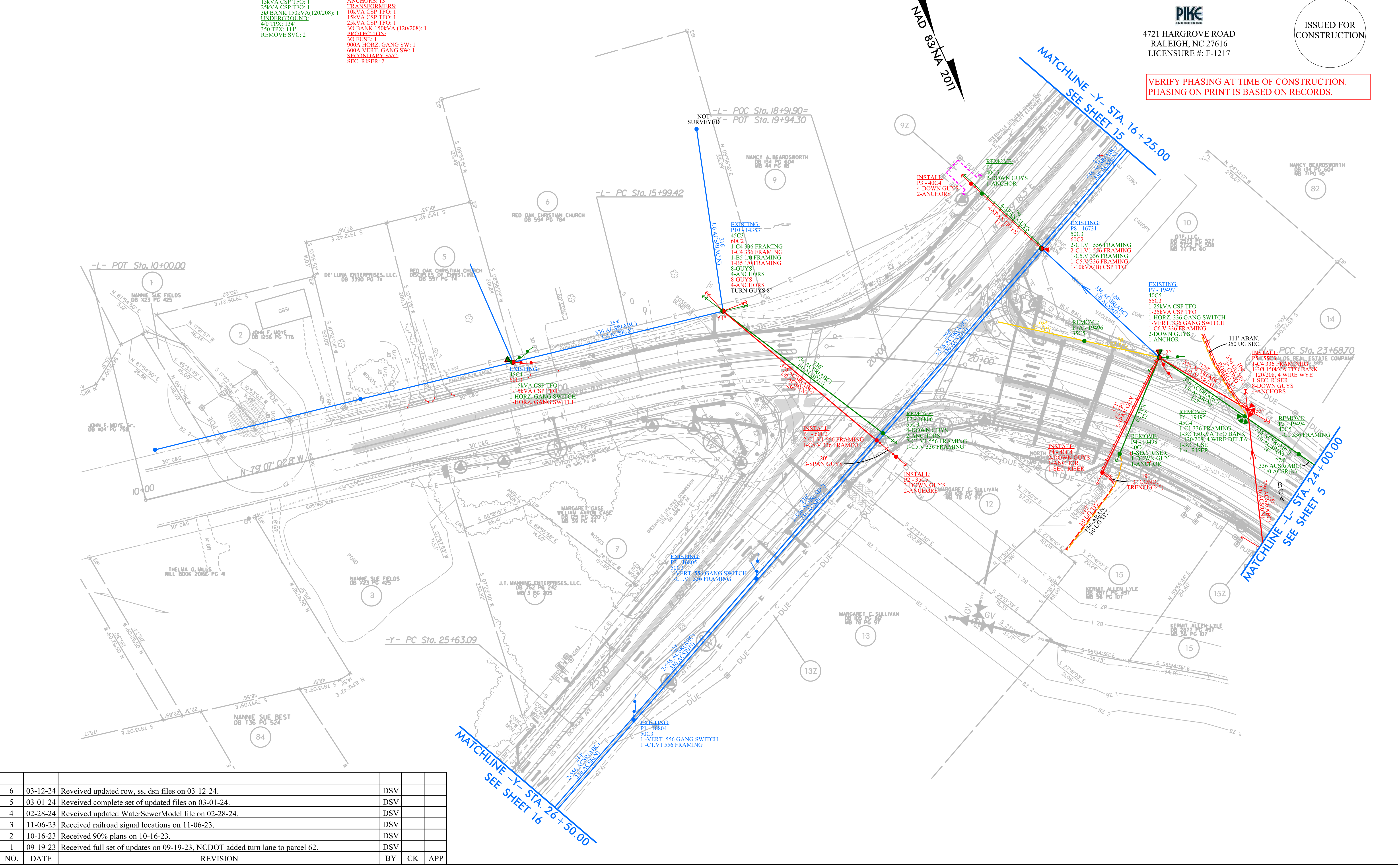

6	03-12-24	Received updated row, ss, dsn files on 03-12-24.	DSV		
5	03-01-24	Received complete set of updated files on 03-01-24.	DSV		
4	02-28-24	Received updated WaterSewerModel file on 02-28-24.	DSV		
3	11-06-23	Received railroad signal locations on 11-06-23.	DSV		
2	10-16-23	Received 90% plans on 10-16-23.	DSV		
1	09-19-23	Received full set of updates on 09-19-23. NCDOT added turn lane to parcel 62.	DSV		
NO.	DATE	REVISION	BY	CK	APP

LEGEND	
	INSTALL (RED)
	REMOVE (GREEN)
	EXISTING TO REMAIN (BLUE)
	ABANDON (ORANGE)
	TEMPORARY (YELLOW)
	PERMANENT UTILITIES EASEMENT
	AERIAL UTILITIES EASEMENT

REMOVALS:	OH INSTALLATIONS:	UG INSTALLATIONS:
POLES:	POLES:	
35: 1	38C3: 2	
50: 7	50C3: 6	
OH CONDUCTORS:	60C2: 1	
336 ACSR: 1653	TAGS: 9	
1/0 ACSR: 1046	CONDUCTORS:	
1/0 TPX: 223	336 ACSR: 2646	
#2 TPX: 203	1/0 ACSR: 1490	
OH MISC:	#2 TPX: 177	
30 FRAMING: 9	FRAMING:	
DOWN GUYS: 14	CT: 4	
ANCHORS: 7	C2: 2	
30 FUSE: 1	C4: 1	
LIGHT: 1	C5: 2	
TRANSFORMERS:	DOWN GUYS: 16	
10 15kVA CSP: 2	SW GUY: 1	
	SPAN GUYS: 6	
	ANCHORS: 12	
	TRANSFORMERS:	
	10 15kVA CSP: 2	
	PROTECTION:	
	30 FUSE: 1	
	SECONDARY:	
	LIGHT: 1	

DETAIL CONSTRUCTION DRAWING	
Site Contact: James Richardson	Phone Number: (919) 612-9716
Site Contact: Danny Cobb	Phone Number: (919) 654-5874
GUC Contact: Jacob Swink	Phone Number: (252) 508-6891
GUC Contact:	Phone Number:
Address: U-5875 Allen Rd 4000 Dickinson Ave Greenville, NC 27834	Scale: 1" = 50' Sheet #: 5

PIKE ENGINEERING
4721 HARGROVE ROAD
RALEIGH, NC 27616
LICENSURE #: F-1217

ISSUED FOR CONSTRUCTION

VERIFY PHASING AT TIME OF CONSTRUCTION.
PHASING ON PRINT IS BASED ON RECORDS.

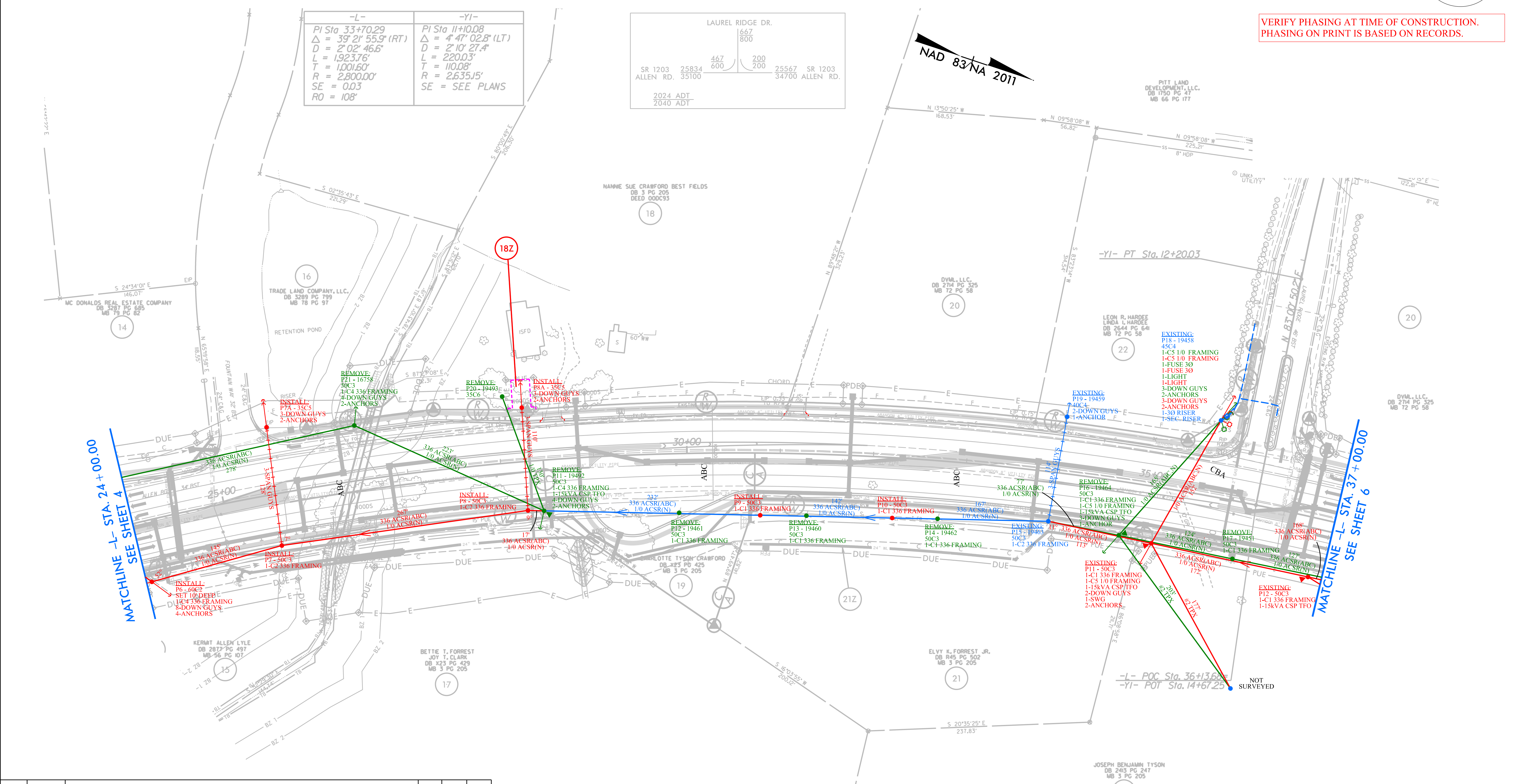

NO.	DATE	REVISION	BY	CK	APP
6	03-12-24	Received updated row, ss, dsn files on 03-12-24.	DSV		
5	03-01-24	Received complete set of updated files on 03-01-24.	DSV		
4	02-28-24	Received updated WaterSewerModel file on 02-28-24.	DSV		
3	11-06-23	Received railroad signal locations on 11-06-23.	DSV		
2	10-16-23	Received 90% plans on 10-16-23.	DSV		
1	09-19-23	Received full set of updates on 09-19-23. NCDOT added turn lane to parcel 62.	DSV		

LEGEND

- INSTALL (RED)
- REMOVE (GREEN)
- EXISTING TO REMAIN (BLUE)
- ABANDON (ORANGE)
- TEMPORARY (YELLOW)
- PERMANENT UTILITIES EASEMENT (DASHED PINK)
- AERIAL UTILITIES EASEMENT (DASHED BLUE)

REMOVALS:

POLES:
35: 1
45: 3
50: 2

OH CONDUCTORS:
1/0 ACSR: 2380'
336 ACSR: 3534'

OH MISC:
DOWN GUY: 17
ANCHOR: 8
10 FRAMING: 4
30 FRAMING: 7
30 200A RISER: 1
30 FUSE: 2
CAP BANK: 1

LG CONDUCTORS:
#12/2 CU: 65'
#6 TPX: 40'
1/0 AWG: 1170'
SEC. PED: 1

OH INSTALLATIONS:

POLES:
40C4: 1
50C3: 4
55C3: 1
TAGS: 6

CONDUCTORS:
#6 TPX: 149'
1/0 ACSR: 2545'
336 ACSR: 3597'

FRAMING:
AS: 1
A5: 3
C1: 2
C2: 2
C4: 2
C5: 2

DOWN GUYS: 22
SW GUY: 2
ANCHORS: 10
TRANSFORMERS: 10
15kVA CSP: 1
PROTECTION: 30
FUSE: 2
RISERS: 30
200A: 1
VOLTAGE: 30
CAP BANK: 1

UG INSTALLATIONS:

EXCAVATION:
BACKHILL: 40'x30'
RESEED: 60'
BORING:
1-2" COND: 192'
2" COND: 192'
4" COND: 30'
4" 90° ELBOW: 2
EQUIPMENT:
200A TERM: 3
SECONDARY:
SEC. PED 9X14: 1
4PT SBR: 1

DETAIL CONSTRUCTION DRAWING

Site Contact: James Richardson Phone Number: (919) 612-9716
 Site Contact: Danny Cobb Phone Number: (919) 654-5874
 GUC Contact: Jacob Swink Phone Number: (252) 508-6891
 GUC Contact: Phone Number:
 Address: U-5875 Allen Rd Scale: 1" = 50'
 4000 Dickinson Ave Greenville, NC 27834 Sheet #: 7



4721 HARGROVE ROAD
RALEIGH, NC 27616
LICENSURE #: F-1217



VERIFY PHASING AT TIME OF CONSTRUCTION.
PHASING ON PRINT IS BASED ON RECORDS.

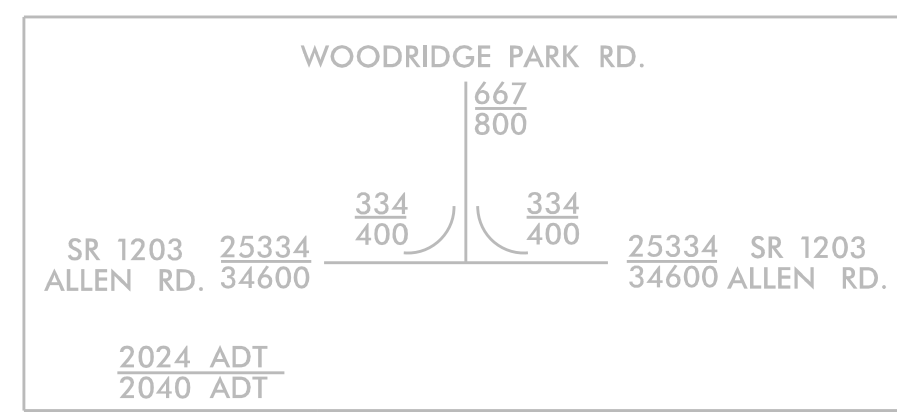
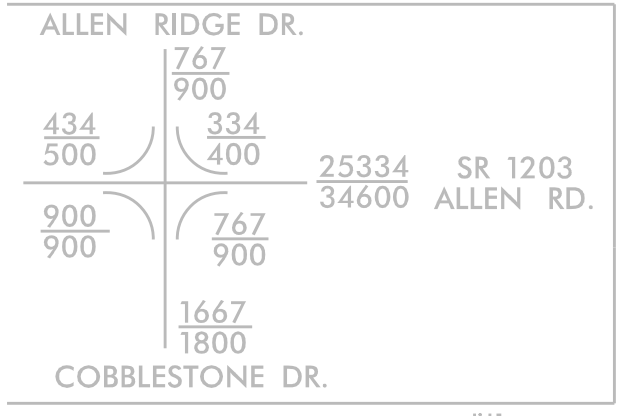
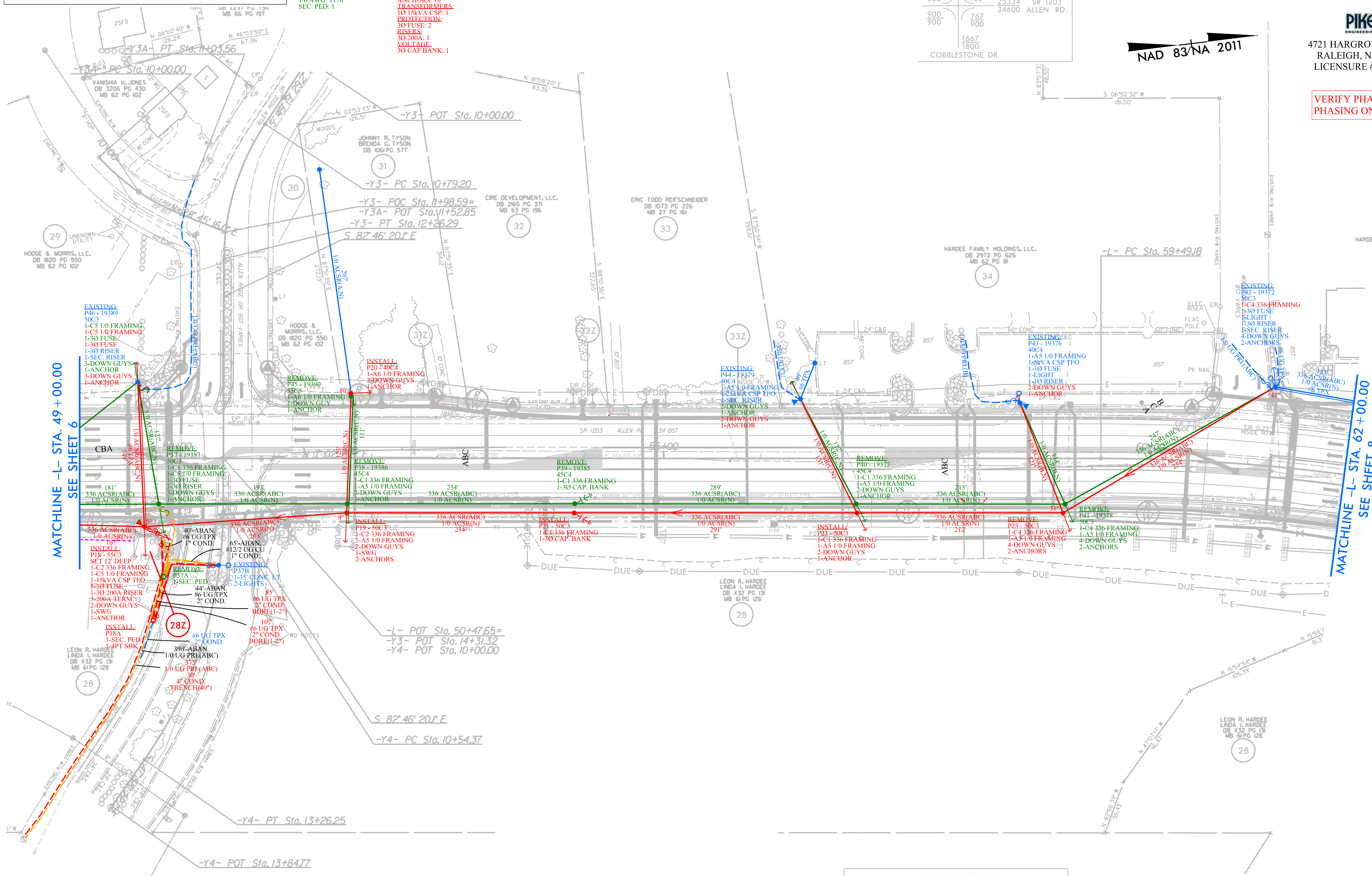

NO.	DATE	REVISION	BY	CK	APP
6	03-12-24	Received updated row, ss, dsn files on 03-12-24.			DSV
5	03-01-24	Received complete set of updated files on 03-01-24.			DSV
4	02-28-24	Received updated WaterSewerModel file on 02-28-24.			DSV
3	11-06-23	Received railroad signal locations on 11-06-23.			DSV
2	10-16-23	Received 90% plans on 10-16-23.			DSV
1	09-19-23	Received full set of updates on 09-19-23. NCDOT added turn lane to parcel 62.			DSV

LEGEND	
	INSTALL (RED)
	REMOVE (GREEN)
	EXISTING TO REMAIN (BLUE)
	ABANDON (ORANGE)
	TEMPORARY (YELLOW)
	PERMANENT UTILITIES EASEMENT
	AERIAL UTILITIES EASEMENT

REMOVALS:
POLES:
 45: 3
OH MISC:
 DOWN GUY: 3
 ANCHOR: 2
 GANG SW: 1
 30 FRAMING: 2
 LIGHTS: 2
 SEC. RISER: 1
TRANSFORMERS:
 10 5KVA CSP: 1
 10 25KVA CSP: 1

OH INSTALLATIONS:
POLES:
 50C3: 2
 TAGS: 2
FRAMING:
 DOWN GUY: 4
 ANCHOR: 2
 C1.V1: 1
 C3: 1
TRANSFORMERS:
 10 10KVA CSP: 1
 10 25KVA CSP: 1
SERVICES:
 LIGHTS: 2
 SEC. RISER: 1

DETAIL CONSTRUCTION DRAWING	
Site Contact: James Richardson	Phone Number: (919) 612-9716
Site Contact: Danny Cobb	Phone Number: (919) 654-5874
GUC Contact: Jacob Swink	Phone Number: (252) 508-6891
GUC Contact:	Phone Number:
Address: U-5875 Allen Rd	Scale: 1" = 50'
	Sheet #: 8



4721 HARGROVE ROAD
 RALEIGH, NC 27616
 LICENSURE #: F-1217



VERIFY PHASING AT TIME OF CONSTRUCTION.
 PHASING ON PRINT IS BASED ON RECORDS.

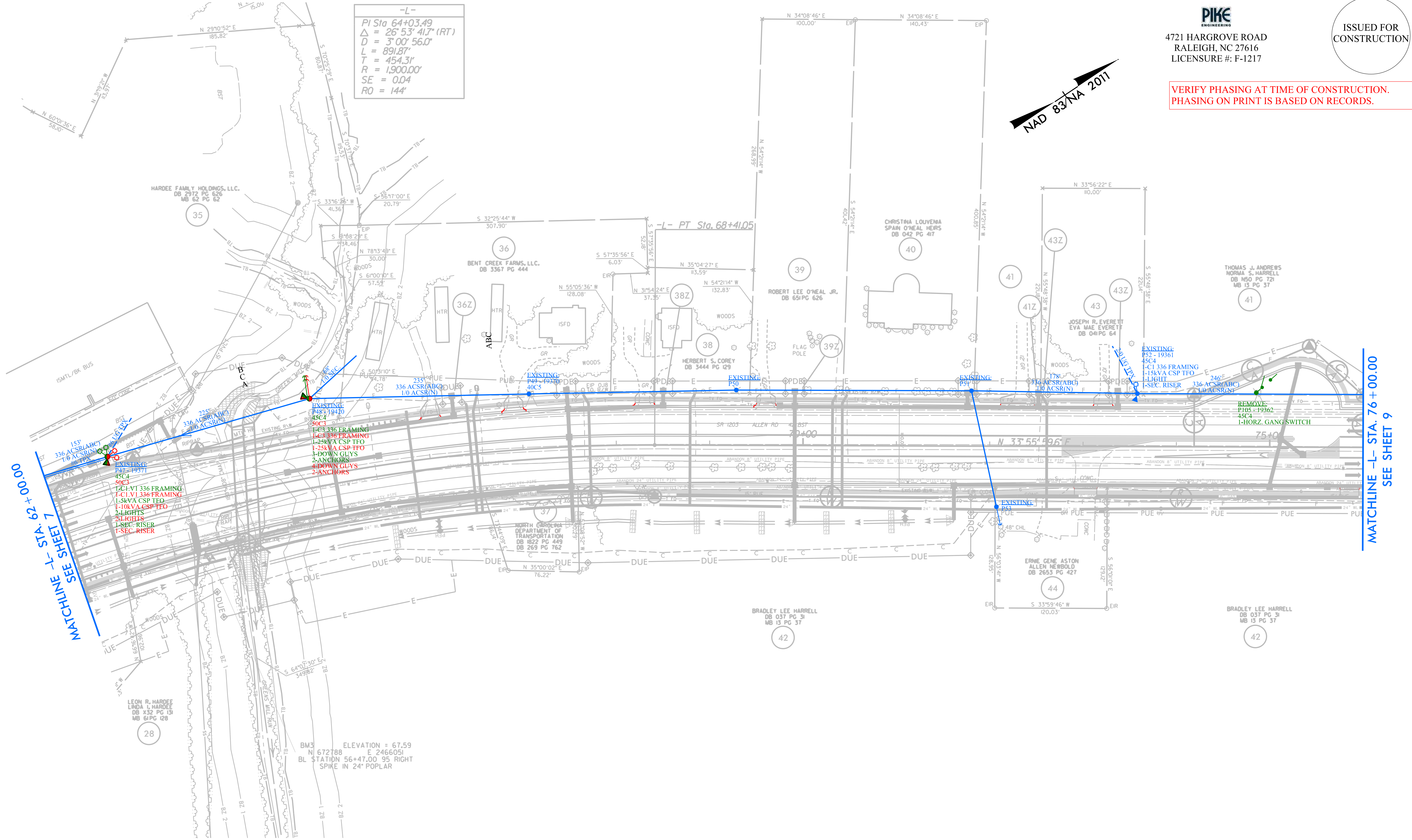

MATCHLINE -L- STA. 76 + 00.00
 SEE SHEET 7

MATCHLINE -L- STA. 76 + 00.00
 SEE SHEET 9

NO.	DATE	REVISION	BY	CK	APP
6	03-12-24	Received updated row, ss, dsn files on 03-12-24.		DSV	
5	03-01-24	Received complete set of updated files on 03-01-24.		DSV	
4	02-28-24	Received updated WaterSewerModel file on 02-28-24.		DSV	
3	11-06-23	Received railroad signal locations on 11-06-23.		DSV	
2	10-16-23	Received 90% plans on 10-16-23.		DSV	
1	09-19-23	Received full set of updates on 09-19-23. NCDOT added turn lane to parcel 62.		DSV	

LEGEND	
—	INSTALL (RED)
—	REMOVE (GREEN)
—	EXISTING TO REMAIN (BLUE)
—	ABANDON (ORANGE)
—	TEMPORARY (YELLOW)
- - -	PERMANENT UTILITIES EASEMENT
- - -	AERIAL UTILITIES EASEMENT

REMOVALS:	OH INSTALLATIONS:	UG INSTALLATIONS:
POLES: 35'-2 45'-4 55'-1	POLES: 35C3: 2 50C3: 5 55C3: 1 TAGS: 8	EXCAVATION: BACKHOE 24": 117' BACKHOE 40": 129' RESEED: 492'
OH CONDUCTORS: 1/0 TPX: 117' 2/0 TPX: 209' 1/0 ACSR: 1410' 336 ACSR: 4230'	CONDUCTORS: 1/0 TPX: 126' 2/0 TPX: 245' 1/0 ACSR: 1371' 336 ACSR: 4113'	BORING: 2" BORE (1 COND.): 55'
OH MISC: DOWN GUY: 18 ANCHOR: 12 30 FRAMING: 5 30 200A RISER: 1 30 FUSE: 1	FRAMING: C1: 1 C2: 3 C3: 1 C4: 1	CONDUIT: 2" COND: 181' 4" COND: 129' 2" 90° ELBOW: 4 2" 45° ELBOW: 2 4" 90° ELBOW: 2 4" 45° ELBOW: 2
TRANSFORMERS: 10 15kVA CSP: 1 10 25kVA CSP: 1 10 25kVA CSP: 1 2/0 TPX: 137' 1/0 SEC: 25' 1/0 PRIM: 522' SEC. PED: 2 30 CAB: 1 SVC IN METER: 1 SVC IN PED: 3	TRANSFORMERS: 10 15kVA CSP: 1 10 25kVA CSP: 1 200A TERM: 1 PROTECTION: 30 FUSE: 1 HORZ. GANG SW: 1	LG PRIMARY: 1/0 PRIM: 387' LG SECONDARY: #6 TPX: 360' 1/0 SEC: 15' 2/0 TPX: 116'
LINDEGROUND: 46 TPX: 514' 2/0 TPX: 137' 1/0 SEC: 25' 1/0 PRIM: 522' SEC. PED: 2 30 CAB: 1 SVC IN METER: 1 SVC IN PED: 3	TRANSFORMERS: 10 15kVA CSP: 1 10 25kVA CSP: 1 200A TERM: 1 PROTECTION: 30 FUSE: 1 HORZ. GANG SW: 1	LG EQUIPMENT: 30 CAB: 1 SVC IN METER: 1 SVC IN PED: 3 4PT SBK: 1
	PROTECTION: 30 FUSE: 1 HORZ. GANG SW: 1	SERVICES: 9X14 PED: 2 9X14 FLAT LID: 2 SVC IN METER: 1 SVC IN PED: 3 4PT SBK: 1
	RISERS: 30 200A RISER: 1 SERVICES: SEC. RISER: 3 LIGHT: 1	

DETAIL CONSTRUCTION DRAWING	
Site Contact: James Richardson	Phone Number: (919) 612-9716
Site Contact: Danny Cobb	Phone Number: (919) 654-5874
GUC Contact: Jacob Swink	Phone Number: (252) 508-6891
GUC Contact:	Phone Number:
Address: U-5875 Allen Rd 4000 Dickinson Ave Greenville, NC 27834	Scale: 1" = 50'
	Sheet #: 9



4721 HARGROVE ROAD
RALEIGH, NC 27616
LICENSURE #: F-1217

VERIFY PHASING AT TIME OF CONSTRUCTION.
PHASING ON PRINT IS BASED ON RECORDS.

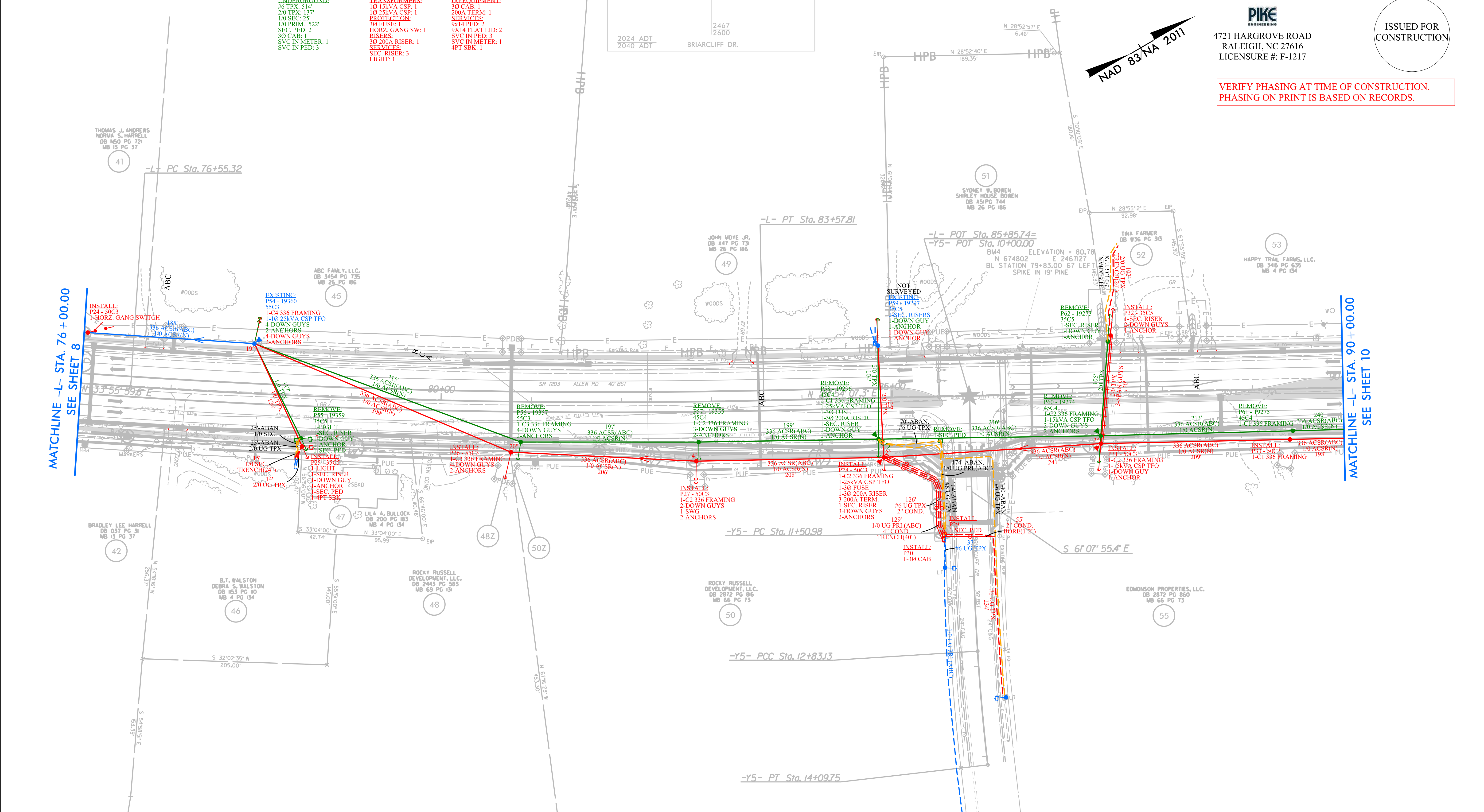

NO.	DATE	REVISION	BY	CK	APP
6	03-12-24	Received updated row, ss, dsn files on 03-12-24.			DSV
5	03-01-24	Received complete set of updated files on 03-01-24.			DSV
4	02-28-24	Received updated WaterSewerModel file on 02-28-24.			DSV
3	11-06-23	Received railroad signal locations on 11-06-23.			DSV
2	10-16-23	Received 90% plans on 10-16-23.			DSV
1	09-19-23	Received full set of updates on 09-19-23. NCDOT added turn lane to parcel 62.			DSV

LEGEND	
	INSTALL (RED)
	REMOVE (GREEN)
	EXISTING TO REMAIN (BLUE)
	ABANDON (ORANGE)
	TEMPORARY (YELLOW)
	PERMANENT UTILITIES EASEMENT
	AERIAL UTILITIES EASEMENT

REMOVALS:	OH INSTALLATIONS:	UG INSTALLATIONS:
POLES: 35'-2 45'-1 50'-3 55'-1	POLES: 35C3: 2 50C3: 1 55C3: 6 TAGS: 9	EXCAVATION: BACKHOE(24"): 13' RESEED: 26' CONDUITS: 7" COND: 13' 2" 90°: 1 4" 90°: 1
OH CONDUCTORS: #2 TPX: 197' 20 TPX: 212' 1/0 ACSR: 1923' 336 ACSR: 4215'	CONDUCTORS: #2 TPX: 218' 20 TPX: 222' 1/0 ACSR: 1776' 336 ACSR: 3732'	LG SECONDARY: 2/0 TPX: 13' SECONDARY: SEC. PED 18X24: 1 4PT SBK: 1
OIL MISC: DOWN GUY: 24 SPAN GUY: 1 ANCHOR: 12 30 FRAMING: 7 30 200A RISER: 1 30 FUSE: 2 CAP. BANK: 1 SEC. RISER: 1 SVC ON POLE: 2	TRANSFORMERS: 10 15kVA CSP: 2 10 25kVA CSP: 1 10 25kVA CSP: 1 10 25kVA CSP: 1 1/0 PRIM.: 39' SEC. PED 18X24: 1	PROTECTION: 30 FUSE: 2 RISERS: 30 200A RISER: 1 VOLTAGE ALTERATION: 30 CAP. BANK: 1 SECONDARY: SEC. RISER: 1 SVC ON POLE: 2

DETAIL CONSTRUCTION DRAWING	
Site Contact: James Richardson	Phone Number: (919) 612-9716
Site Contact: Danny Cobb	Phone Number: (919) 654-5874
GUC Contact: Jacob Swink	Phone Number: (252) 508-6891
GUC Contact:	Phone Number:
Address: U-5875 Allen Rd 4000 Dickinson Ave Greenville, NC 27834	Scale: 1" = 50' Sheet #: 10



4721 HARGROVE ROAD
RALEIGH, NC 27616
LICENSURE #: F-1217



VERIFY PHASING AT TIME OF CONSTRUCTION.
PHASING ON PRINT IS BASED ON RECORDS.

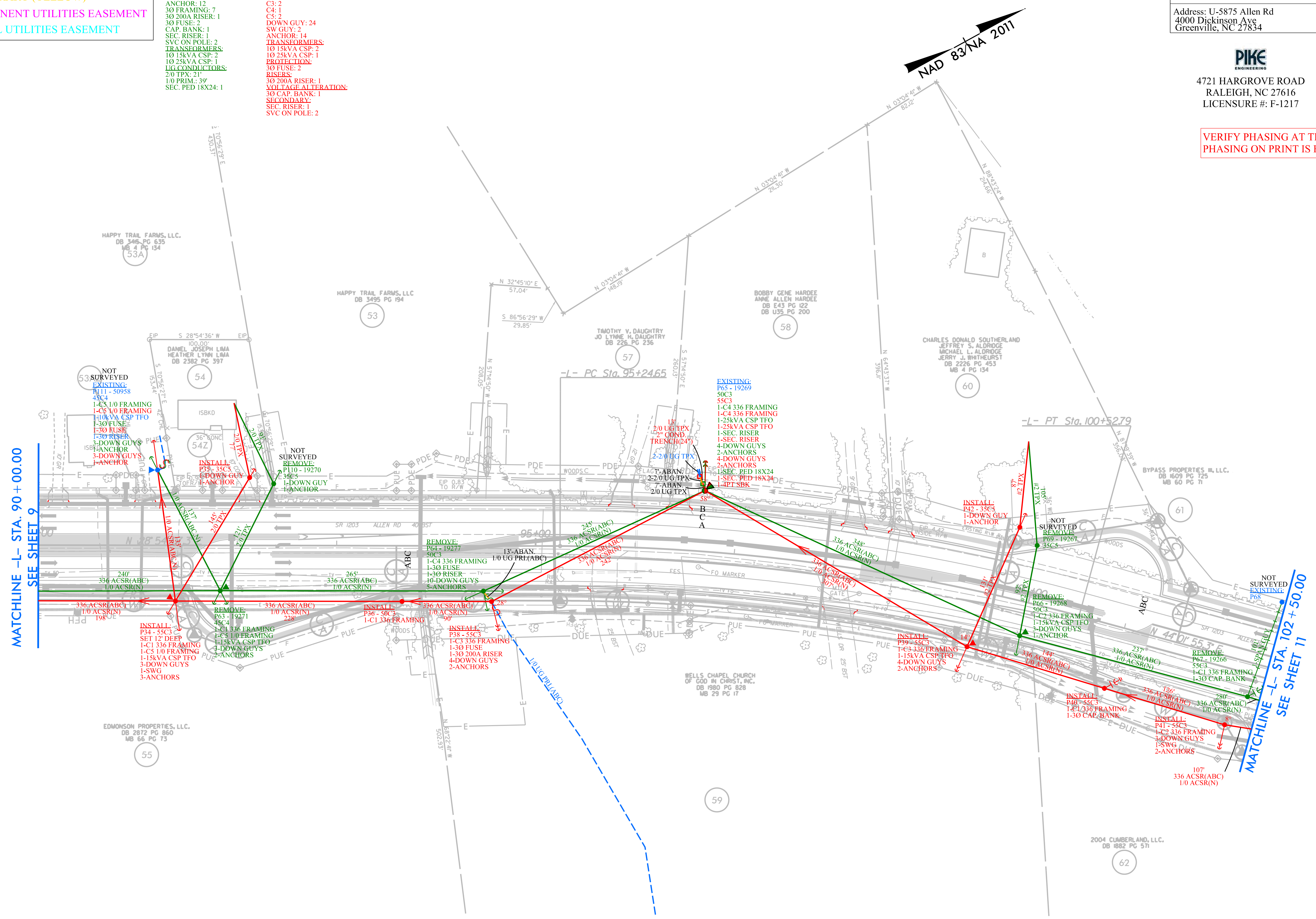

NO.	DATE	REVISION	BY	CK	APP
6	03-12-24	Received updated row, ss, dsn files on 03-12-24.			DSV
5	03-01-24	Received complete set of updated files on 03-01-24.			DSV
4	02-28-24	Received updated WaterSewerModel file on 02-28-24.			DSV
3	11-06-23	Received railroad signal locations on 11-06-23.			DSV
2	10-16-23	Received 90% plans on 10-16-23.			DSV
1	09-19-23	Received full set of updates on 09-19-23. NCDOT added turn lane to parcel 62.			DSV

LEGEND	
	INSTALL (RED)
	REMOVE (GREEN)
	EXISTING TO REMAIN (BLUE)
	ABANDON (ORANGE)
	TEMPORARY (YELLOW)
	PERMANENT UTILITIES EASEMENT
	AERIAL UTILITIES EASEMENT

REMOVALS:	OH INSTALLATIONS:	UG INSTALLATIONS:
POLES: 55: 1	POLES: 33C: 1	
OH CONDUCTORS: 10 ACSR: 723'	60C: 2	
336 ACSR: 2169'	65C: 1	
OH MISC.: DOWN GUYS: 7	TAGS: 4	
ANCHORS: 3	CONDUCTORS: #6 TPX: 94'	
30 FRAMING: 3	10 ACSR: 917'	
GANG SW: 1	336 ACSR: 2751'	
DISCONNECT SW: 3	FRAMING: C6: 2	
TRANSFORMERS: 10 10kVA CSP: 1	C6 V: 1	
10 10kVA CSP: 1	DOWN GUY: 16	
	SW GUY: 1	
	SPAN GUY: 3	
	ANCHOR: 10	
	TRANSFORMERS: 10 10kVA CSP: 1	
	PROTECTION: 30 600A INLINE SW: 3	
	30 600A VERT. GANG SW: 1	

DETAIL CONSTRUCTION DRAWING	
Site Contact: James Richardson	Phone Number: (919) 612-9716
Site Contact: Danny Cobb	Phone Number: (919) 654-5874
GUC Contact: Jacob Swink	Phone Number: (252) 508-6891
GUC Contact:	Phone Number:
Address: U-5875 Allen Rd 4000 Dickinson Ave Greenville, NC 27834	Scale: 1" = 50'
	Sheet #: 11



4721 HARGROVE ROAD
RALEIGH, NC 27616
LICENSURE #: F-1217



VERIFY PHASING AT TIME OF CONSTRUCTION.
PHASING ON PRINT IS BASED ON RECORDS.

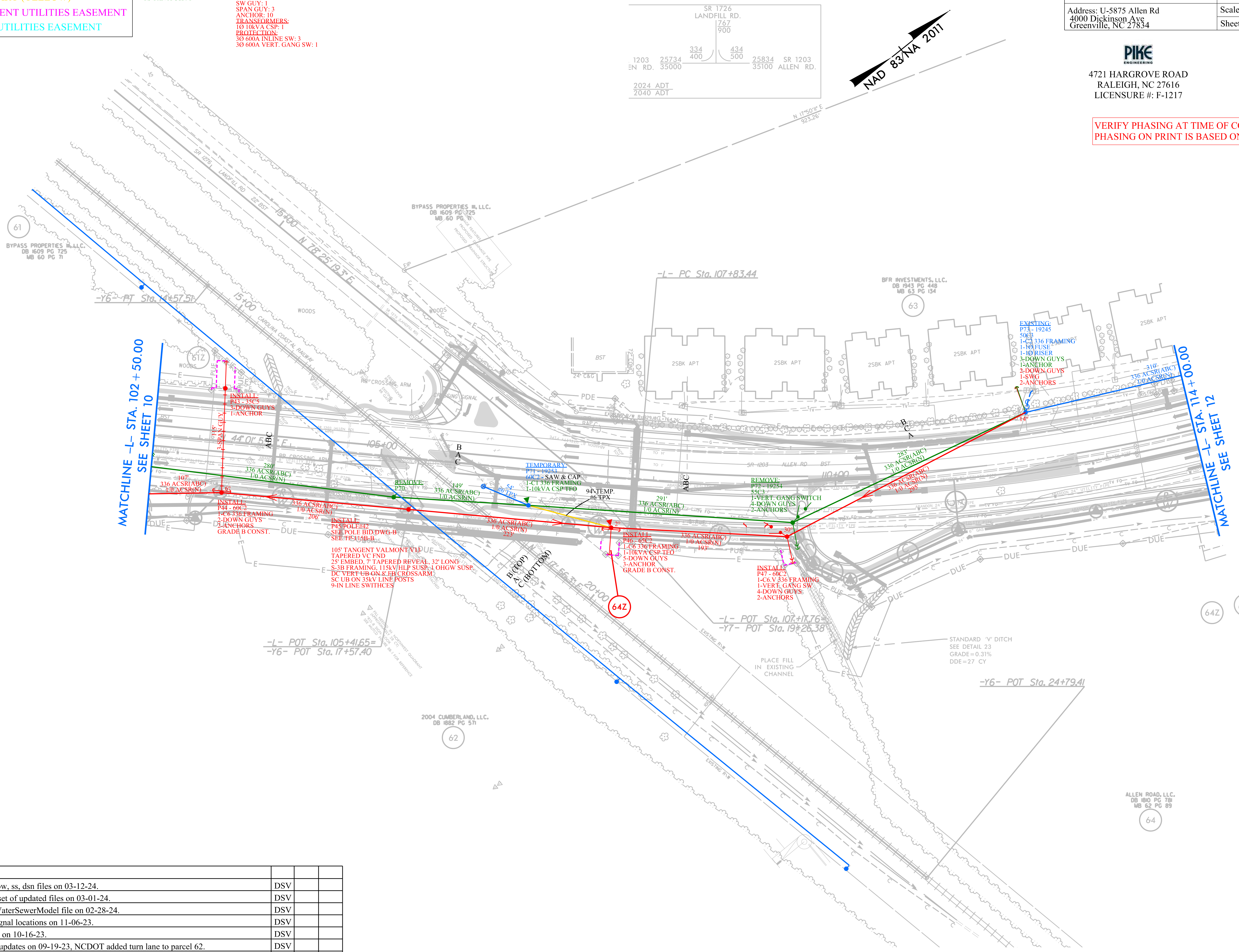

NO.	DATE	REVISION	BY	CK	APP
6	03-12-24	Received updated row, ss, dsn files on 03-12-24.			DSV
5	03-01-24	Received complete set of updated files on 03-01-24.			DSV
4	02-28-24	Received updated WaterSewerModel file on 02-28-24.			DSV
3	11-06-23	Received railroad signal locations on 11-06-23.			DSV
2	10-16-23	Received 90% plans on 10-16-23.			DSV
1	09-19-23	Received full set of updates on 09-19-23. NCDOT added turn lane to parcel 62.			DSV

LEGEND	
	INSTALL (RED)
	REMOVE (GREEN)
	EXISTING TO REMAIN (BLUE)
	ABANDON (ORANGE)
	TEMPORARY (YELLOW)
	PERMANENT UTILITIES EASEMENT
	AERIAL UTILITIES EASEMENT

REMOVALS:
POLES:
 35'-2
 40'-2
 45'-2
OH CONDUCTORS:
 1/0 TPX: 130'
 1/0 ACSR: 480'
 336 ACSR: 1032'
MISC. OH:
 DOWN GUY: 3
 SPAN GUY: 3
 ANCHOR: 2
 30 FRAMING: 4
 10 200A RISER: 1
 20 200A RISER: 1
 30 200A RISER: 1
 10 FUSE: 1
 20 FUSE: 1
 30 FUSE: 1
LIGHT:
 SVC ON POLE: 1
TRANSFORMERS:
 10 15kVA CSP: 1
LANDSCAPE:
 #6 TPX: 133'
 2/0 TPX: 56'
 1/0 PRI: 1067'
 SVC IN PED/TFO: 2

OH INSTALLATIONS:
POLES:
 35'-2
 45'-2
 50'-3: 1
 55'-3: 1
TAGS: 6
CONDUCTORS:
 1/0 TPX: 75'
 1/0 ACSR: 544'
 336 ACSR: 1632'
FRAMING:
 C1: 1
 C2: 1
 DOWN GUY: 17
 ANCHOR: 9
TRANSFORMERS:
 SPAN GUY: 1
PROTECTION:
 10 FUSE: 1
 20 FUSE: 1
 30 FUSE: 1
RISERS:
 10 200A: 1
 20 200A: 1
 30 200A: 1
SEC. SVC:
 SEC. RISER: 2
LIGHT: 1

UG INSTALLATIONS:
EXCAVATION:
 BACKHOE 24": 25'
 BACKHOE 40": 99'
 RESEED: 248'
BORING:
 BORE (1-2"): 151'
 BORE (1-4"): 318'
CONDUIT:
 2" CONDUIT: 275'
 4" CONDUIT: 318'
 7" 90° ELBOW: 4
 2" 45° ELBOW: 3
 4" 90° ELBOW: 3
UG PRIMARY:
 #6 TPX: 151'
 2/0 TPX: 28'
UG SECONDARY:
 20 CAB: 1
 200A LBE: 4
 200A TERM: 6
SEC. PED/SVC:
 SEC. PED 9X14: 1
 SVC IN PED/TFO: 2
 SVC IN METER: 1
 4PT SBK: 1

DETAIL CONSTRUCTION DRAWING



Site Contact: James Richardson
 Site Contact: Danny Cobb
 GUC Contact: Jacob Swink
 GUC Contact:
 Address: U-5875 Allen Rd
 4000 Dickinson Ave
 Greenville, NC 27834

Phone Number: (919) 612-9716
 Phone Number: (919) 654-5874
 Phone Number: (252) 508-6891
 Phone Number:
 Scale: 1" = 50'
 Sheet #: 12

PIKE ENGINEERING
 4721 HARGROVE ROAD
 RALEIGH, NC 27616
 LICENSURE #: F-1217

ISSUED FOR CONSTRUCTION

VERIFY PHASING AT TIME OF CONSTRUCTION.
 PHASING ON PRINT IS BASED ON RECORDS.

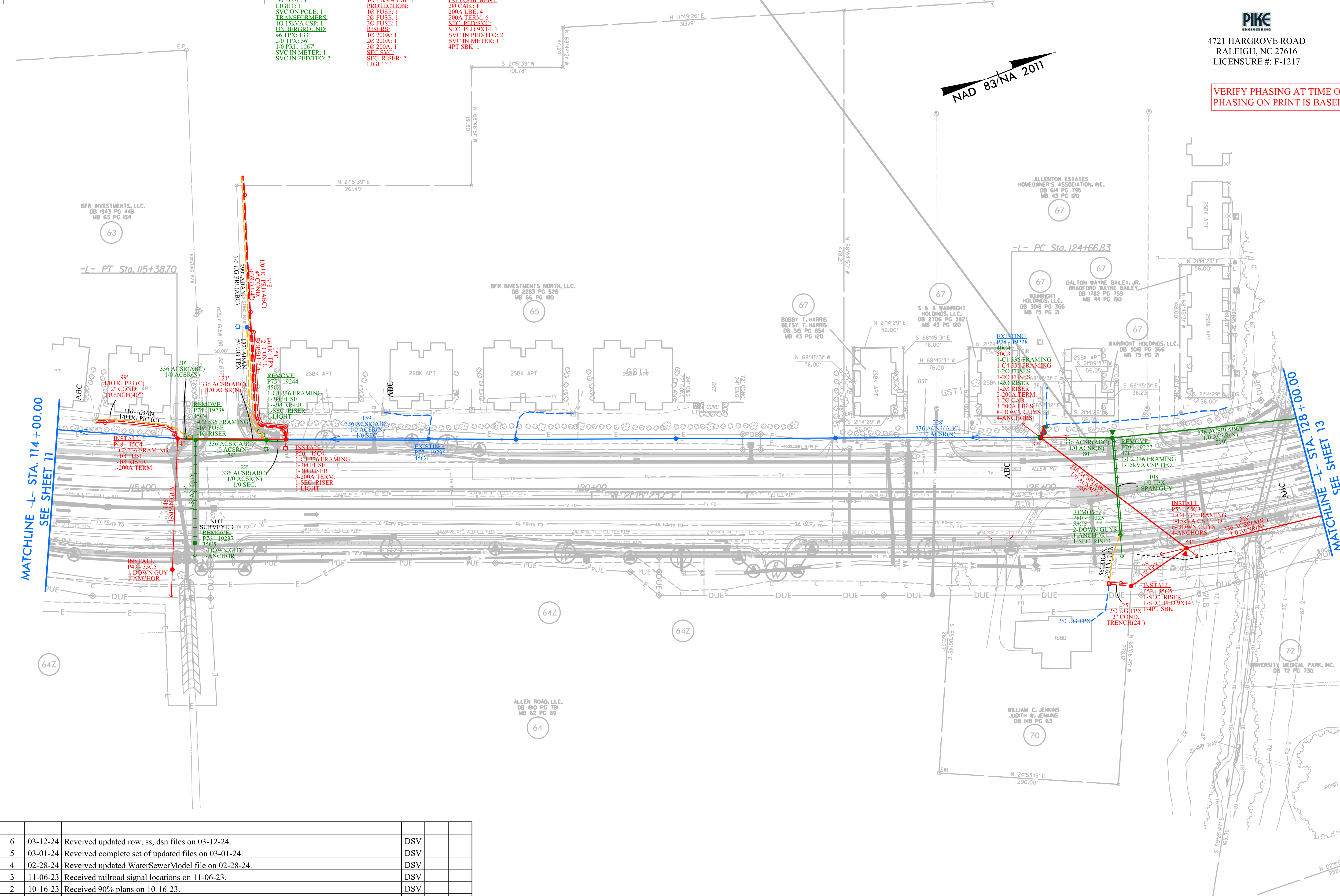

6	03-12-24	Received updated row, ss, dsn files on 03-12-24.	DSV		
5	03-01-24	Received complete set of updated files on 03-01-24.	DSV		
4	02-28-24	Received updated WaterSewerModel file on 02-28-24.	DSV		
3	11-06-23	Received railroad signal locations on 11-06-23.	DSV		
2	10-16-23	Received 90% plans on 10-16-23.	DSV		
1	09-19-23	Received full set of updates on 09-19-23. NCDOT added turn lane to parcel 62.	DSV		
NO.	DATE	REVISION	BY	CK	APP

LEGEND	
	INSTALL (RED)
	REMOVE (GREEN)
	EXISTING TO REMAIN (BLUE)
	ABANDON (ORANGE)
	TEMPORARY (YELLOW)
	PERMANENT UTILITIES EASEMENT
	AERIAL UTILITIES EASEMENT

REMOVALS:	OH INSTALLATIONS:
POLES: 35: 1 45: 2 50: 2	POLES: 50C3: 4 TAGS: 4
OH CONDUCTORS: 1/0 ACSR: 1052' 336 ACSR: 3156'	CONDUCTORS: 1/0 ACSR: 939' 336 ACSR: 2877'
OIL MISC: DOWN GUY: 6 SPAN GUY: 3 ANCHOR: 3 30 FRAMING: 3 GANG SWITCH: 1	FRAMING: C1: 2 C2: 1 DOWN GUY: 2 SW GUY: 1 ANCHOR: 2 PROTECTION: HORZ. GANG SW: 1

DETAIL CONSTRUCTION DRAWING	
Site Contact: James Richardson	Phone Number: (919) 612-9716
Site Contact: Danny Cobb	Phone Number: (919) 654-5874
GUC Contact: Jacob Swink	Phone Number: (252) 508-6891
GUC Contact:	Phone Number:
Address: U-5875 Allen Rd 4000 Dickinson Ave Greenville, NC 27834	Scale: 1" = 50' Sheet #: 13



4721 HARGROVE ROAD
RALEIGH, NC 27616
LICENSURE #: F-1217



VERIFY PHASING AT TIME OF CONSTRUCTION.
PHASING ON PRINT IS BASED ON RECORDS.

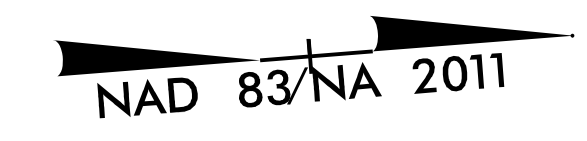

-L-	
PI Sta	126+58.61
Δ	= 16' 47" 01.2" (LT)
D	= 4' 24" 26.5"
L	= 380.81'
T	= 191.78'
R	= 1,300.00'
SE	= 0.04
RO	= 144'

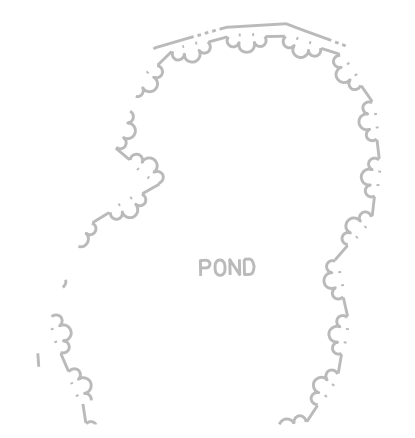
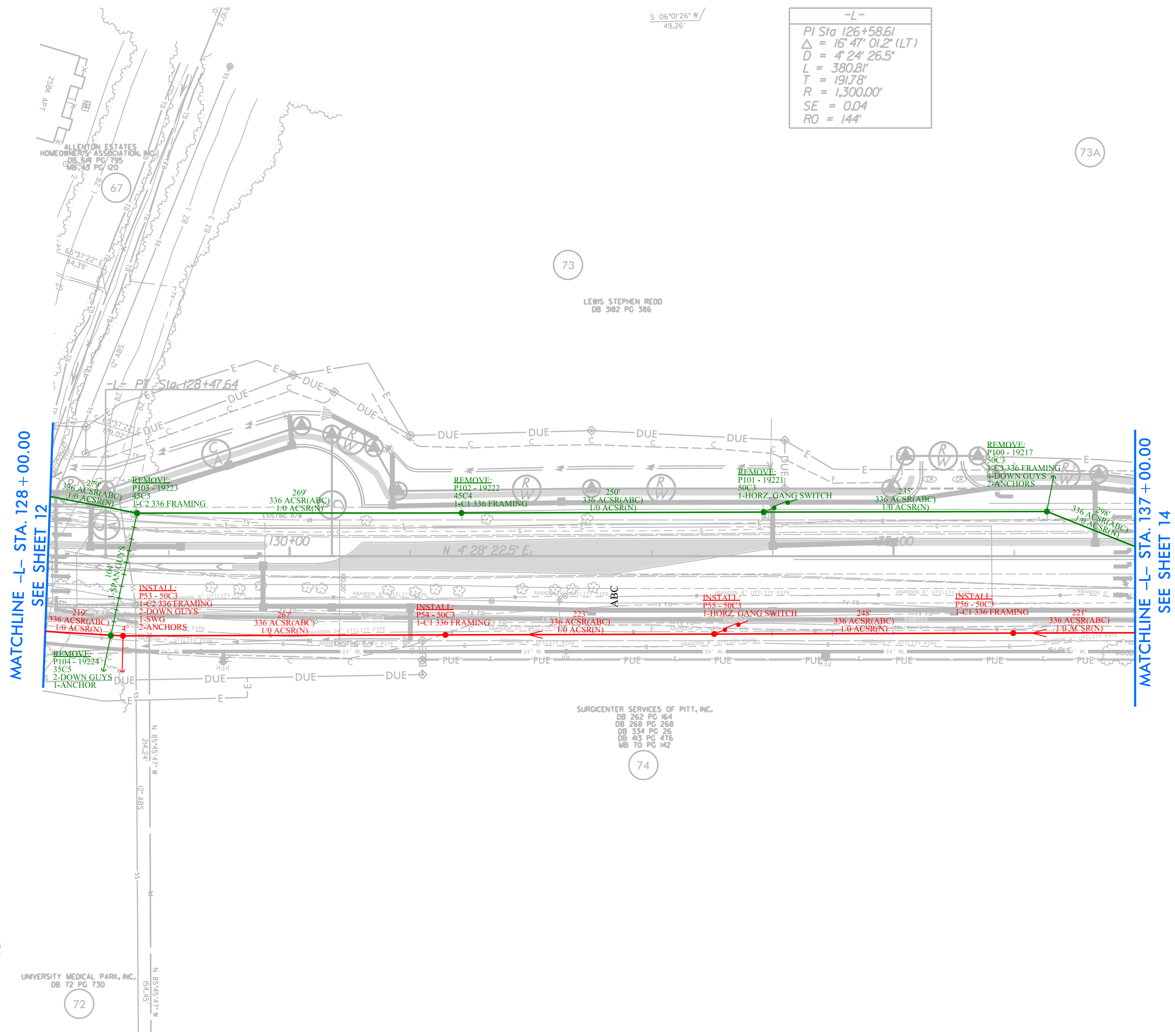

UNIVERSITY MEDICAL PARK, INC.
DB 72 PG 730

SURGICENTER SERVICES OF PITT, INC.
DB 262 PG 164
DB 268 PG 268
DB 334 PG 26
DB 403 PG 416
MB 70 PG 142

NO.	DATE	REVISION	BY	CK	APP
6	03-12-24	Received updated row, ss, dsn files on 03-12-24.			DSV
5	03-01-24	Received complete set of updated files on 03-01-24.			DSV
4	02-28-24	Received updated WaterSewerModel file on 02-28-24.			DSV
3	11-06-23	Received railroad signal locations on 11-06-23.			DSV
2	10-16-23	Received 90% plans on 10-16-23.			DSV
1	09-19-23	Received full set of updates on 09-19-23. NCDOT added turn lane to parcel 62.			DSV

LEGEND	
	INSTALL (RED)
	REMOVE (GREEN)
	EXISTING TO REMAIN (BLUE)
	ABANDON (ORANGE)
	TEMPORARY (YELLOW)
	PERMANENT UTILITIES EASEMENT
	AERIAL UTILITIES EASEMENT

REMOVALS:
POLES:
 35: 1
 40: 1
 45: 1
 50: 1
 55: 3
OH CONDUCTORS:
 #2 TFX: 416
 1-0 ACSR: 451'
 336 ACSR: 2987'
 795 AAC: 2292'
OH MISC:
 DOWN GUYS: 26
 SPAN GUYS: 4
 ANCHORS: 17
 30 FRAMING: 11
 10 200A RISER: 1
 30 200A RISER: 1
 10 FUSE: 1
 DISCONNECT SW: 2
 LIGHT: 1
 SVC ON POLE: 2
TRANSFORMERS:
 10 10kVA CSP: 1
 UNDERGROUND:
 10 PRI: 274'
 SVC IN METER: 2

OH INSTALLATIONS:
POLES:
 35C: 1
 55C: 3
 60C: 4
 65C: 2
TAGS: 10
OH CONDUCTORS:
 #2 TFX: 410'
 1-0 ACSR: 548'
 336 ACSR: 2263'
 795 AAC: 3156'
FRAMING:
 1-0 PRI: 294'
 CI.VI: 7
 C2: 1
 C4: 6
 C5.V: 2
 C6.V: 1
 DOWN GUYS: 44
 ANCHORS: 23
 SPAN GUYS: 12
TRANSFORMERS:
 10 10kVA CSP: 1
PROTECTION:
 10 FUSE: 1
 30 FUSE: 1
 RISERS:
 10 200A RISER: 1
 30 200A RISER: 1

UG INSTALLATIONS:
EXCAVATION:
 TRENCH: 40' 5"
 RESEED: 10'
BORING:
 1-2" 274'
CONDUITS:
 2" PVC: 274'
 5" PVC: 5'
 2" 90° PVC E: 2
 5" 90° PVC E: 2
UG PRIMARY:
 1-0 PRI: 294'
UG TEOS & EQUIPMENT:
 200A LBE: 5
 200A TERM: 5

DETAIL CONSTRUCTION DRAWING	
Site Contact: James Richardson	Phone Number: (919) 612-9716
Site Contact: Danny Cobb	Phone Number: (919) 654-5874
GUC Contact: Jacob Swink	Phone Number: (252) 508-6891
GUC Contact:	Phone Number:
Address: U-5875 Allen Rd 4000 Dickinson Ave Greenville, NC 27834	Scale: 1" = 50' Sheet #: 14



4721 HARGROVE ROAD
 RALEIGH, NC 27616
 LICENSURE #: F-1217



VERIFY PHASING AT TIME OF CONSTRUCTION.
 PHASING ON PRINT IS BASED ON RECORDS.

MATCHLINE -L- STA. 137 + 00.00
 SEE SHEET 13

MATCHLINE -Y8- STA. 19 + 00.00
 SEE SHEET 17

-L2-	
PI Sta 12+74.77	PI Sta 13+90.18
$\Delta = 25'09" 22.0' (RT)$	$\Delta = 0'04" 05.3' (RT)$
$D = 16'44" 17.4'$	$D = 0'04" 55.5'$
$L = 150.29'$	$L = 82.99'$
$T = 76.36'$	$T = 41.49'$
$R = 342.31'$	$R = 69.79519'$
SE = SEE PLANS	

NO.	DATE	REVISION	BY	CK	APP
6	03-12-24	Received updated row, ss, dsn files on 03-12-24.		DSV	
5	03-01-24	Received complete set of updated files on 03-01-24.		DSV	
4	02-28-24	Received updated WaterSewerModel file on 02-28-24.		DSV	
3	11-06-23	Received railroad signal locations on 11-06-23.		DSV	
2	10-16-23	Received 90% plans on 10-16-23.		DSV	
1	09-19-23	Received full set of updates on 09-19-23. NCDOT added turn lane to parcel 62.		DSV	

Appendix B: Standard Pole Framing

[Balance of Page Left Blank Intentionally]

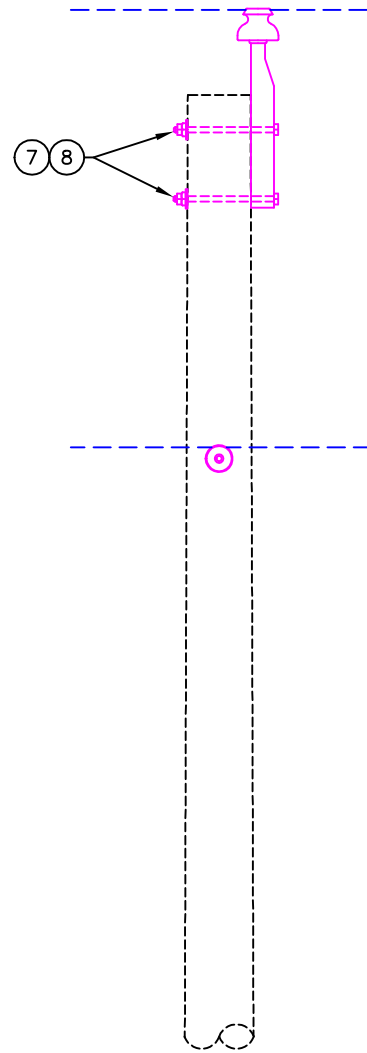
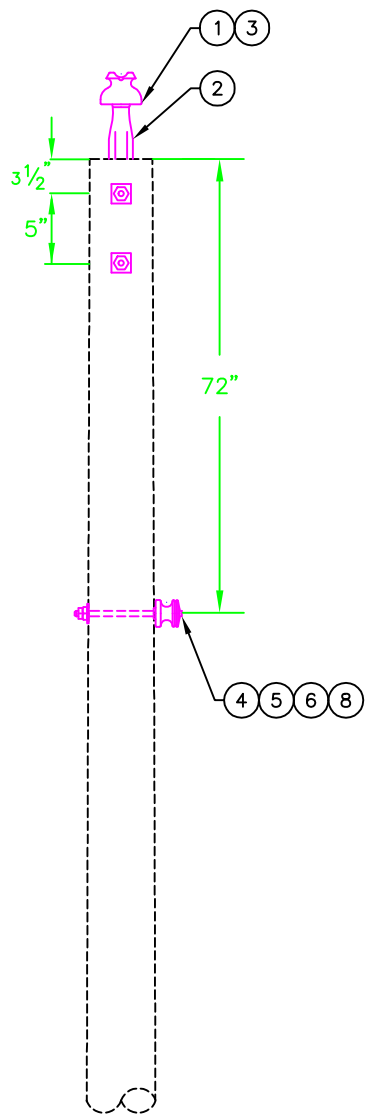

NOTES:

- 1) SEE DRAWINGS DN-GG AND DM-9 FOR INFORMATION AND MATERIALS RELATED TO GROUNDING.

DWG REF	QTY	LIST OF MATERIALS		GREENVILLE UTILITIES COMMISSION GREENVILLE, NORTH CAROLINA					
		DESCRIPTION	STOCK #	7.2KV PRIMARY, SINGLE PHASE TANGENT, SINGLE PIN/POST					
1	1	INSULATORS, 15 kV PIN TYPE	203710		DWN.	JLS	DATE:	08/21/19	DWG. NO. A1
2	1	PIN, 18" POLE TOP	203430		CKD.	KW	APPD.		
3	1	PREFORMS, 1/0 WRAP TIE	203590		SCALE:	NONE			
4	1	INSULATORS, SPOOL "J-151"	208280		DATE	REVISION	DATE	REVISION	
5	1	BOLTS, 5/8" x 12" SPOOL	202000						
6	1	PREFORMS, 1/0 SPOOL TIE	203650						
7	2	BOLTS, 5/8" x 12"	202070						
8	3	WASHERS, 2 1/4" SQUARE	204440						

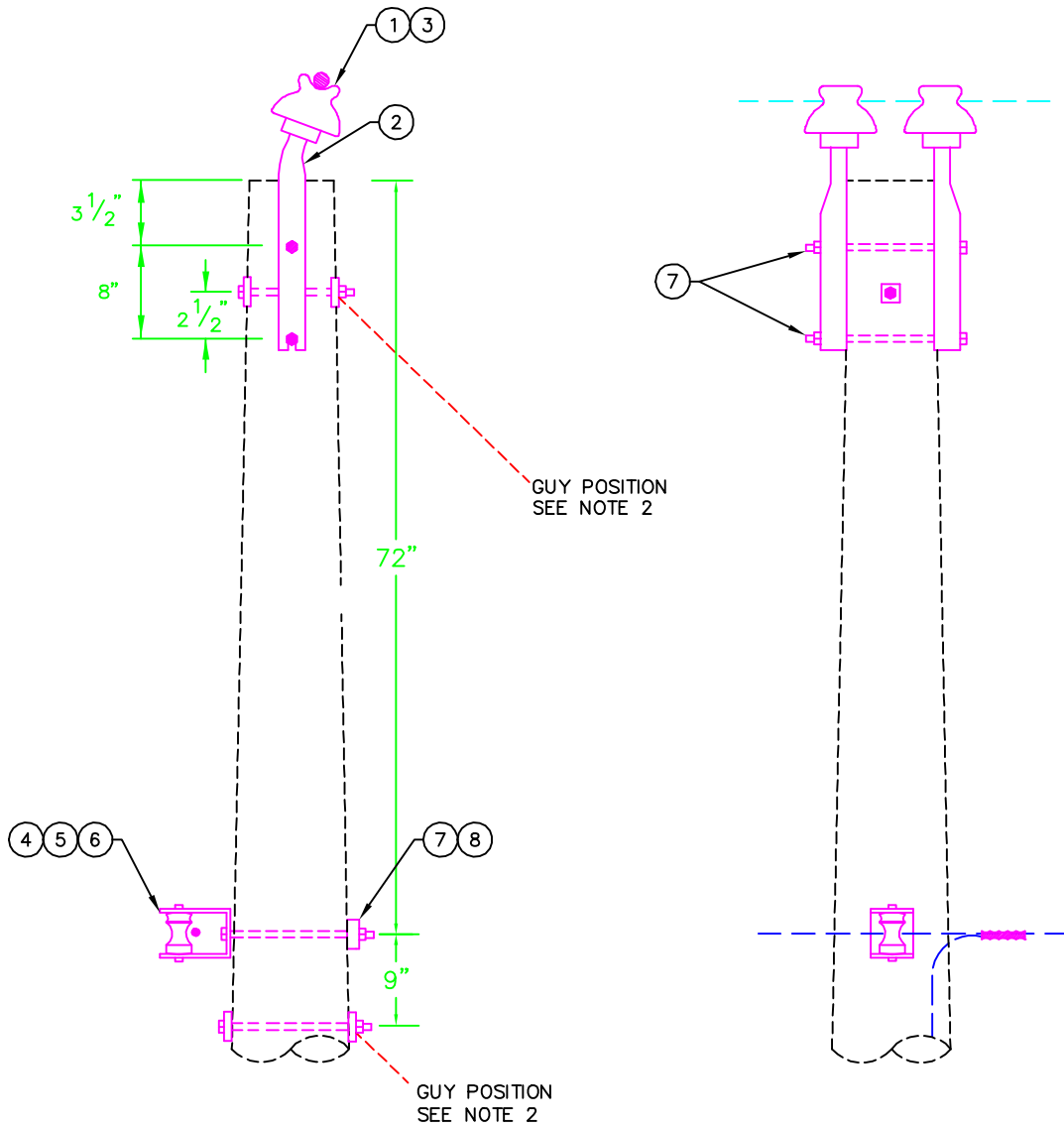

NOTES:

- 1) LINE ANGLE FOR A DOUBLE PIN INSULATOR SHOULD BE (1°-12°).
- 2) SEE DRAWINGS DG-12(14), DG-GG, AND DM-9 FOR INFORMATION AND MATERIALS RELATED TO GUYING AND GROUNDING.

DWG REF	QTY	LIST OF MATERIALS		GREENVILLE UTILITIES COMMISSION GREENVILLE, NORTH CAROLINA				
		DESCRIPTION	STOCK #	 7.2KV PRIMARY, SINGLE PHASE SMALL ANGLE, DOUBLE PIN OR POST				
1	2	INSULATORS, 15 kV PIN TYPE	203710					DWN.
2	2	PIN, ANGLE POLE TOP	206000	CKD.	KW	APPD.		
3	1	PREFORMS, 1/0 DOUBLE SUPPORT	203580	SCALE:	NTS			
4	1	INSULATORS, SPOOL "J-151"	208280	DATE	REVISION	DATE	REVISION	
5	1	CLEVIS, 1342	208290					
6	1	PREFORMS, 1/0 SPOOL TIE	203650					
7	3	BOLTS, 5/8" x 12"	202070					
8	1	WASHERS, 3 X 3 CURVED	204450					

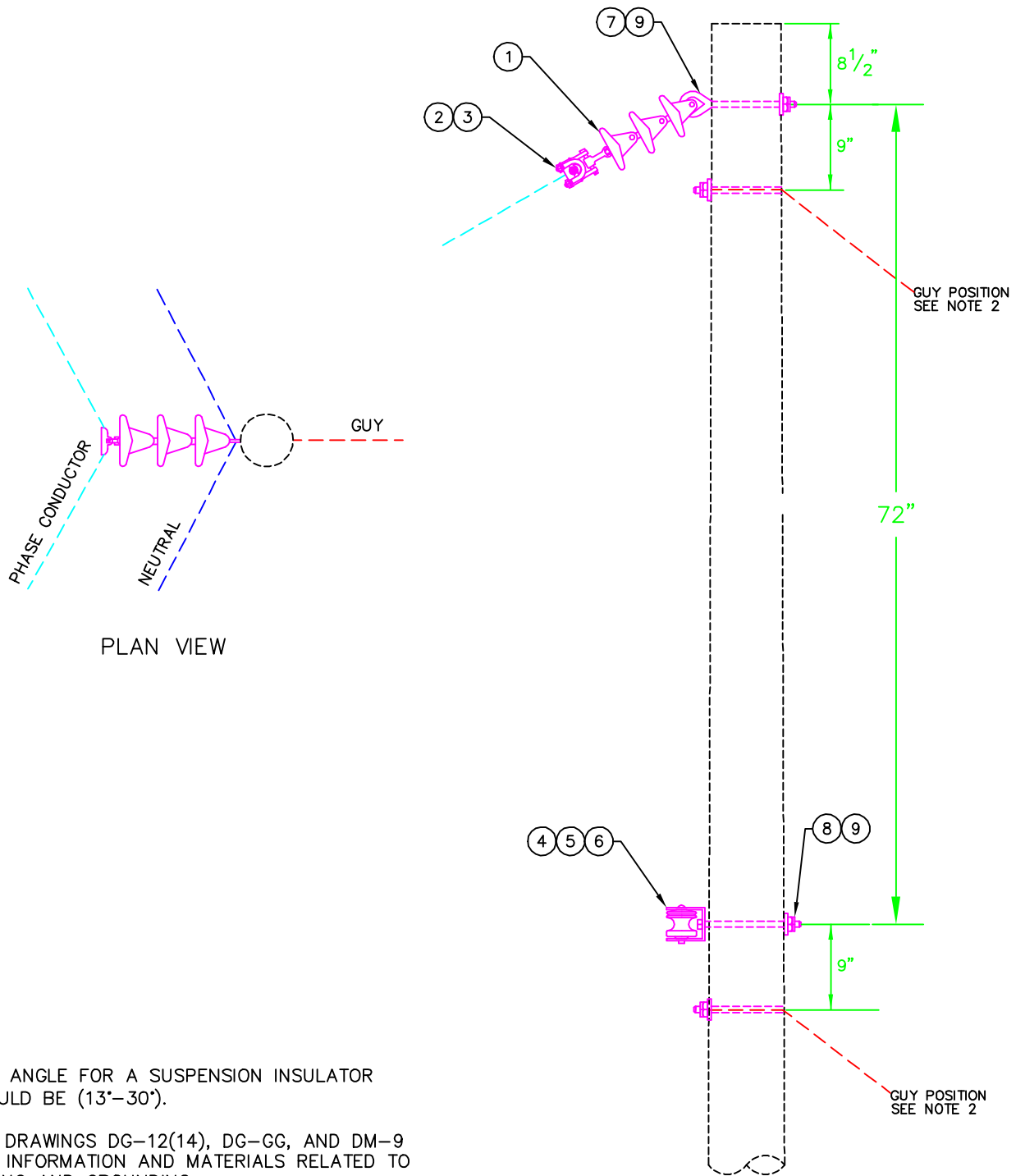

NOTES:

- 1) LINE ANGLE FOR A SUSPENSION INSULATOR SHOULD BE (13°-30°).
- 2) SEE DRAWINGS DG-12(14), DG-GG, AND DM-9 FOR INFORMATION AND MATERIALS RELATED TO GUYING AND GROUNDING.

DWG REF	QTY	LIST OF MATERIALS		GREENVILLE UTILITIES COMMISSION GREENVILLE, NORTH CAROLINA					
		DESCRIPTION	STOCK #						
1	1	INSULATORS, POLYMER DEAD END BELLS	206920		7.2KV PRIMARY, SINGLE PHASE LARGE ANGLE, SUSPENSION INSULATOR			DWG. NO. A3	
2	1	CLAMPS, 1/0 SUSPENSION	202420						
3	1	RODS, 1/0 ARMOR	201960						
4	1	INSULATORS, SPOOL "J-151"	208280		DWN.	JLS	DATE: 08/21/2019		
5	1	CLEVIS, 1342	208290		CKD.	KW	APPD.		
6	1	PREFORMS, 1/0 SPOOL TIE	203650		SCALE:	NONE			
7	1	BOLTS, 5/8" x 10" EYE	202280		DATE	REVISION	DATE		REVISION
8	1	BOLTS, 5/8" x 12"	202070						
9	2	WASHERS, 3 X 3 CURVED	204450						

GUY POSITION

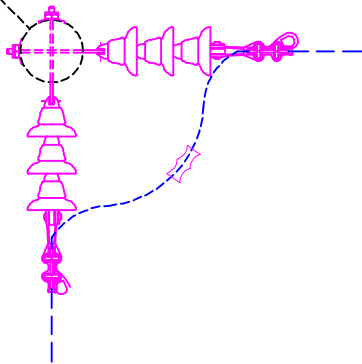

PLAN VIEW

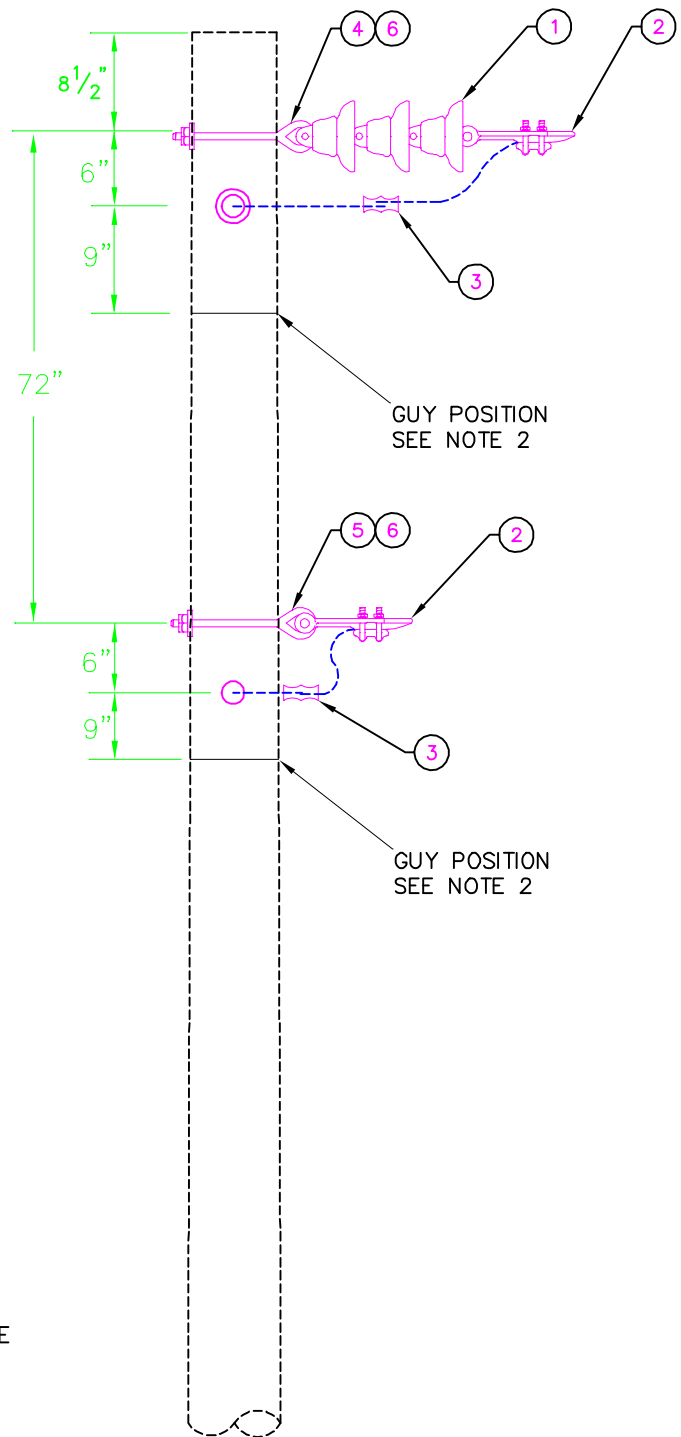

NOTES:

- 1) LINE ANGLE FOR A DOUBLE DEADEND SHOULD BE GREATER THAN 30°.
- 2) SEE DRAWINGS DG-12(14), DG-GG, AND DM-9 FOR INFORMATION AND MATERIALS RELATED TO GUYING AND GROUNDING.

DWG REF	QTY	LIST OF MATERIALS		GREENVILLE UTILITIES COMMISSION GREENVILLE, NORTH CAROLINA			
		DESCRIPTION	STOCK #		7.2KV PRIMARY, SINGLE PHASE LARGE ANGLE, DOUBLE DEADEND SUSPENSION		
1	2	INSULATORS, POLYMER DEAD END BELLS	206920		DWN. JLS CKD. KW SCALE: NONE DATE REVISION DATE REVISION	DATE: 08/22/2019	
2	4	SHOE, #6 - 1/0 DEAD END	207570	APPD.			
3	2	SQUEEZONS, #4	203010				
4	2	BOLTS, 5/8" x 10" EYE	202280				
5	2	BOLTS, 5/8" x 12" EYE	202290				
6	4	WASHERS, 3 X 3 CURVED	204450				

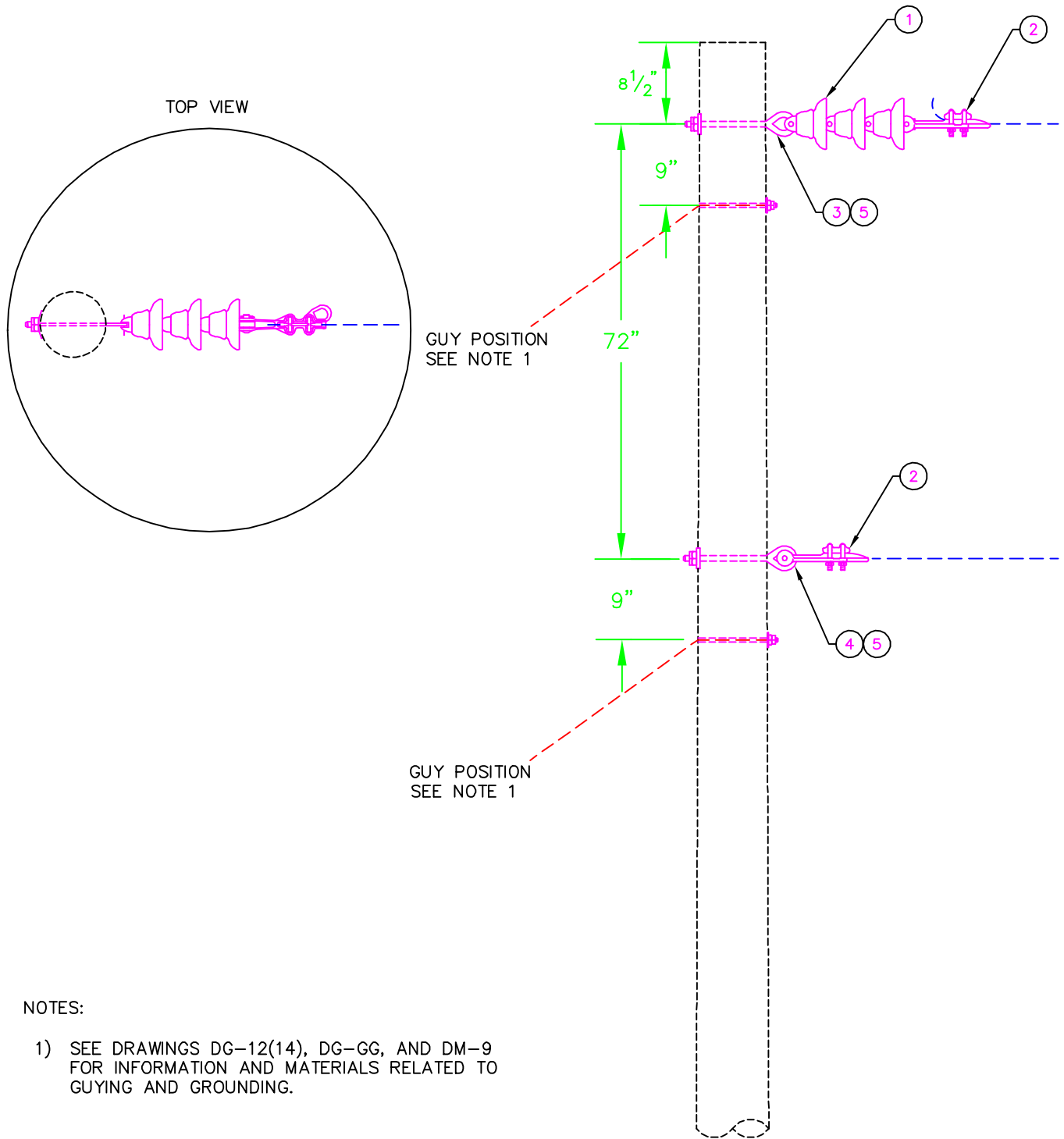

NOTES:

- 1) SEE DRAWINGS DG-12(14), DG-GG, AND DM-9 FOR INFORMATION AND MATERIALS RELATED TO GUYING AND GROUNDING.

DWG REF	QTY	LIST OF MATERIALS		GREENVILLE UTILITIES COMMISSION GREENVILLE, NORTH CAROLINA			
		DESCRIPTION	STOCK #	 7.2KV PRIMARY, SINGLE PHASE SINGLE DEADEND (TAP), SUSPENSION			
1	1	INSULATORS, POLYMER DEAD END BELLS	206920				
2	2	SHOE, #6 - 1/0 DEAD END	207570	APPD.			
3	1	BOLTS, 5/8" x 10" EYE	202280				
4	1	BOLTS, 5/8" x 12" EYE	202290				
5	2	WASHERS, 3 X 3 CURVED	204450				

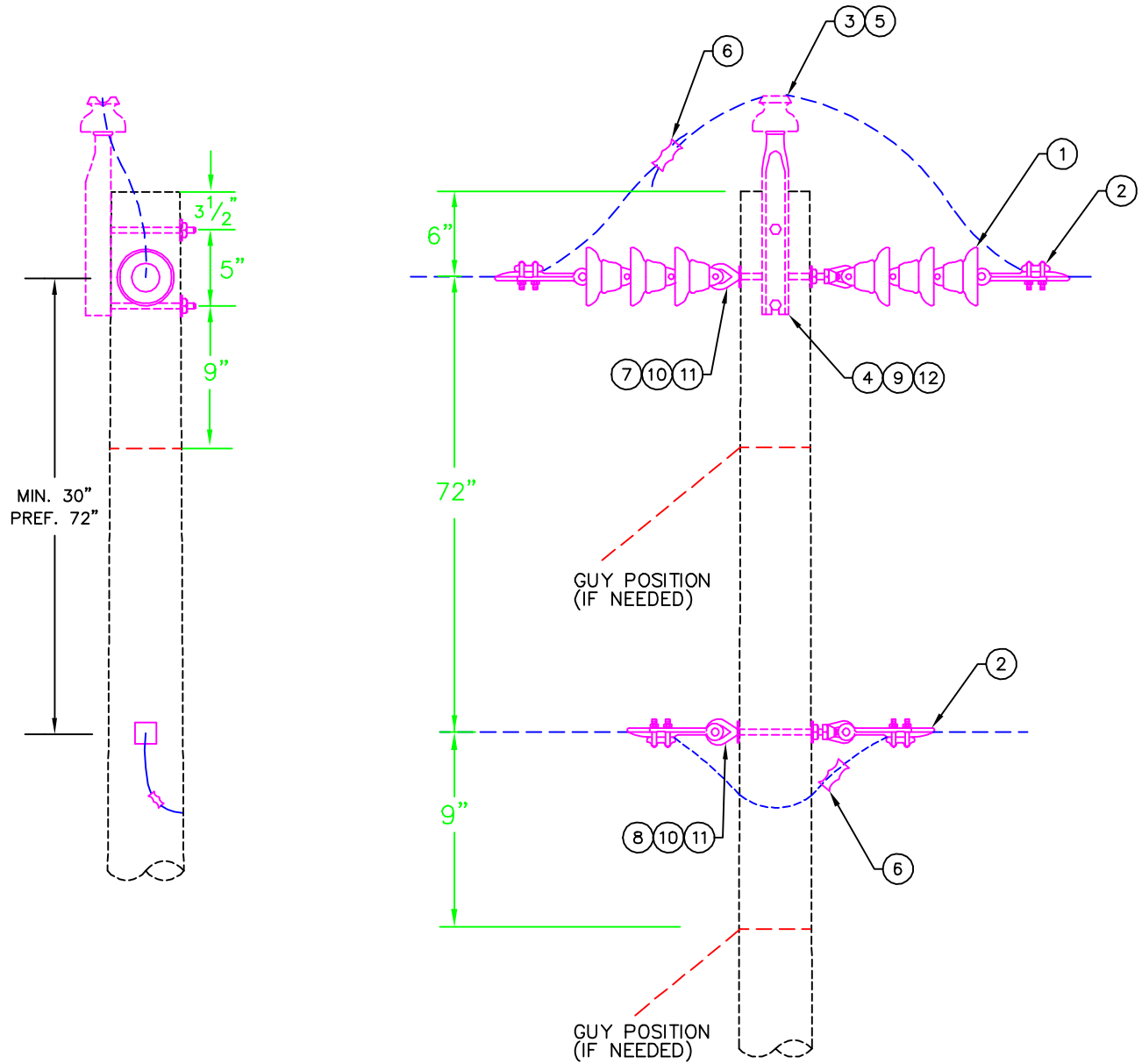

NOTES:

- 1) SEE DRAWINGS DG-12(14), DG-GG, AND DM-9 FOR INFORMATION AND MATERIALS RELATED TO GUYING AND GROUNDING.

DWG REF	QTY	LIST OF MATERIALS	
		DESCRIPTION	STOCK #
1	2	INSULATORS, POLYMER DEAD END BELLS	206920
2	4	SHOE, #6 - 1/0 DEAD END	207570
3	1	INSULATORS, 15 kV PIN TYPE	203710
4	1	PIN, 18" POLE TOP	203430
5	1	PREFORMS, 1/0 WRAP TIE	203590
6	2	SQUEEZONS, #4	203010
7	1	BOLTS, 5/8" x 10" EYE	202280
8	1	BOLTS, 5/8" x 12" EYE	202290
9	2	BOLTS, 5/8" x 12"	202070
10	2	NUTS, 5/8" EYE	204420
11	2	WASHERS, 3 X 3 CURVED	204450
12	2	2 1/4" SQUARE WASHER	204440

GREENVILLE UTILITIES COMMISSION
GREENVILLE, NORTH CAROLINA



7.2KV PRIMARY, SINGLE PHASE
TANGENT, DOUBLE DEADEND SUSPENSION

DWN.	JLS	DATE: 08/22/2019	
CKD.	KW	APPD.	
SCALE: NONE			
DATE	REVISION	DATE	REVISION

DWG. NO.
A6

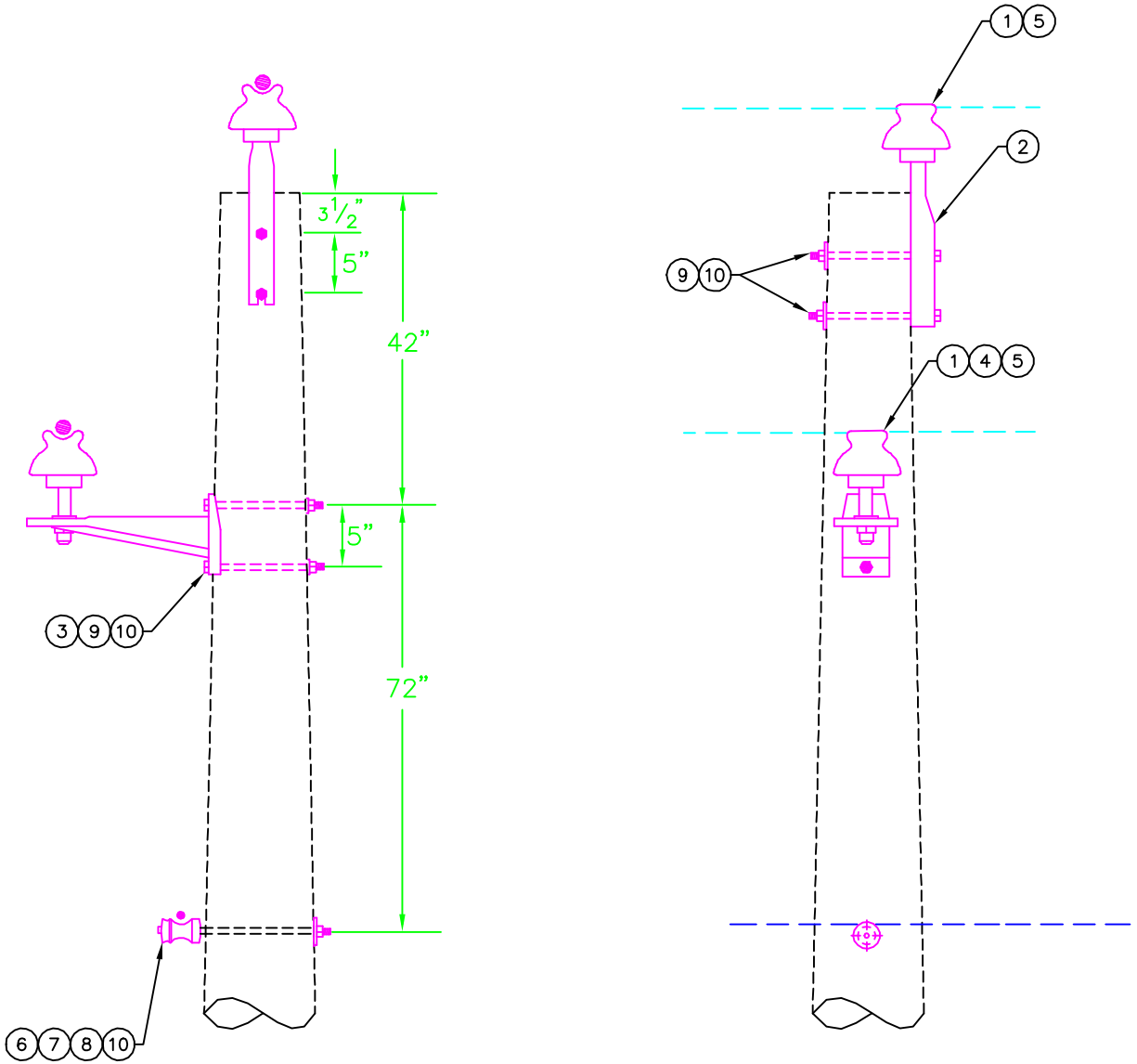

NOTES:

- 1) SEE DRAWINGS DN-GG AND DM-9 FOR INFORMATION AND MATERIALS RELATED GROUNDING.

DWG REF	QTY	LIST OF MATERIALS		GREENVILLE UTILITIES COMMISSION GREENVILLE, NORTH CAROLINA					
		DESCRIPTION	STOCK #	12.47/7.2KV PRIMARY, TWO PHASE TANGENT, MIF CONSTRUCTION SINGLE PIN					
1	2	INSULATORS, 15 kV PIN TYPE	203710		DWN.	JLS	DATE:	08/23/2019	DWG. NO. B1
2	1	PIN, 18" POLE TOP	203430		CKD.	EGS	APPD.		
3	1	BRACKETS, MIF	203420	SCALE:	NTS				
4	1	PIN, SHANK	203440	DATE	REVISION	DATE	REVISION		
5	2	PREFORMS, 1/0 WRAP TIE	203590						
6	1	INSULATORS, SPOOL "J-151"	208280						
7	1	BOLTS, 5/8" x 12" SPOOL	202000						
8	1	PREFORMS, 1/0 SPOOL TIE	203650						
9	4	BOLTS, 5/8" x 12"	202070						
10	5	WASHERS, 2 1/4" SQUARE	204440						

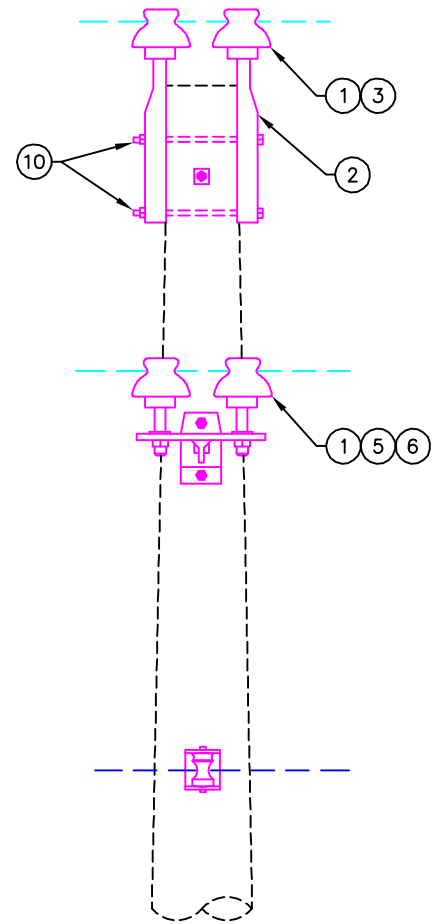
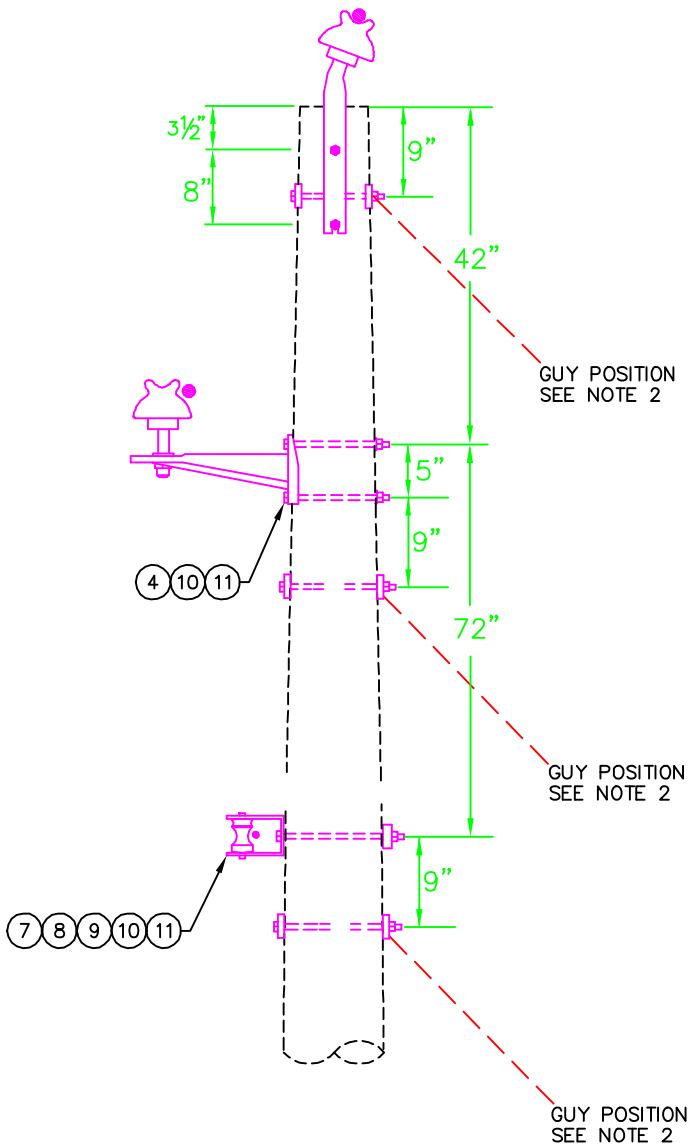

NOTES:

- 1) LINE ANGLE FOR A DOUBLE PIN INSULATOR SHOULD BE (1°-12°).
- 2) SEE DRAWINGS DG-12(14), DG-GG, AND DM-9 FOR INFORMATION AND MATERIALS RELATED TO GUYING AND GROUNDING.

DWG REF	QTY	LIST OF MATERIALS	
		DESCRIPTION	STOCK #
1	4	INSULATORS, 15 kV PIN TYPE	203710
2	2	PIN, ANGLE POLE TOP	206000
3	1	PREFORMS, 1/0 DOUBLE SUPPORT	203580
4	1	BRACKETS, MIF	203420
5	2	PIN, SHANK	203440
6	1	PREFORMS, 1/0 DOUBLE SIDE TIE	203540
7	1	INSULATORS, SPOOL "J-151"	208280
8	1	CLEVIS, 1342	208290
9	1	PREFORMS, 1/0 SPOOL TIE	203650
10	5	BOLTS, 5/8" x 12"	202070
11	3	WASHERS, 3 X 3 CURVED	204450

GREENVILLE UTILITIES COMMISSION
GREENVILLE, NORTH CAROLINA



12.47/7.2KV PRIMARY, TWO PHASE
SMALL ANGLE, MIF CONSTRUCTION DOUBLE PIN

DWN.	JLS	DATE:	08/23/2019
CKD.	KW	APPD.	
SCALE:	NTS		
DATE	REVISION	DATE	REVISION

DWG. NO.
B2

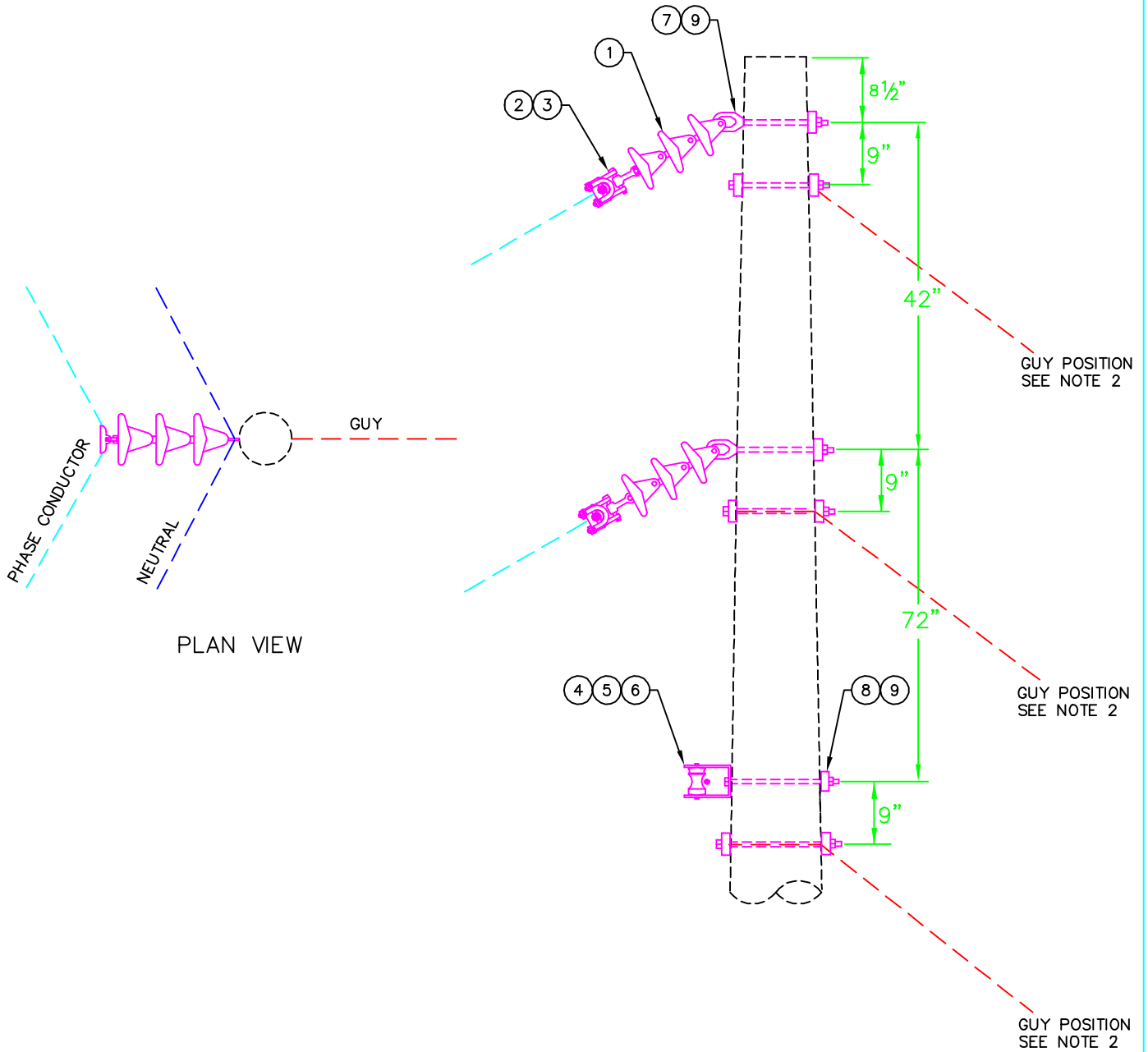

NOTES:

- 1) LINE ANGLE FOR A SUSPENSION INSULATOR SHOULD BE (13°-30°).
- 2) SEE DRAWINGS DG-12(14), DG-GG, AND DM-9 FOR INFORMATION AND MATERIALS RELATED TO GUYING AND GROUNDING.

DWG REF	QTY	LIST OF MATERIALS		GREENVILLE UTILITIES COMMISSION GREENVILLE, NORTH CAROLINA			
		DESCRIPTION	STOCK #	 12.47/7.2KV PRIMARY, TWO PHASE LARGE ANGLE, SUSPENSION INSULATOR			
1	2	INSULATORS, POLYMER DEAD END BELLS	206920				
2	2	CLAMPS, 1/0 SUSPENSION	202420				
3	2	RODS, 1/0 ARMOR	201960				
4	1	INSULATORS, SPOOL "J-151"	208280	APPD.			
5	1	CLEVIS, 1342	208290				
6	1	PREFORMS, 1/0 SPOOL TIE	203650				
7	2	BOLTS, 5/8" x 12" EYE	202290				
8	1	BOLTS, 5/8" x 12"	202070				
9	3	WASHERS, 3 X 3 CURVED	204450				

GUY POSITION

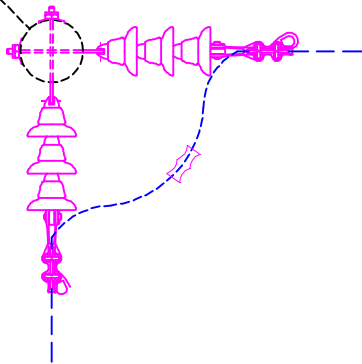

PLAN VIEW

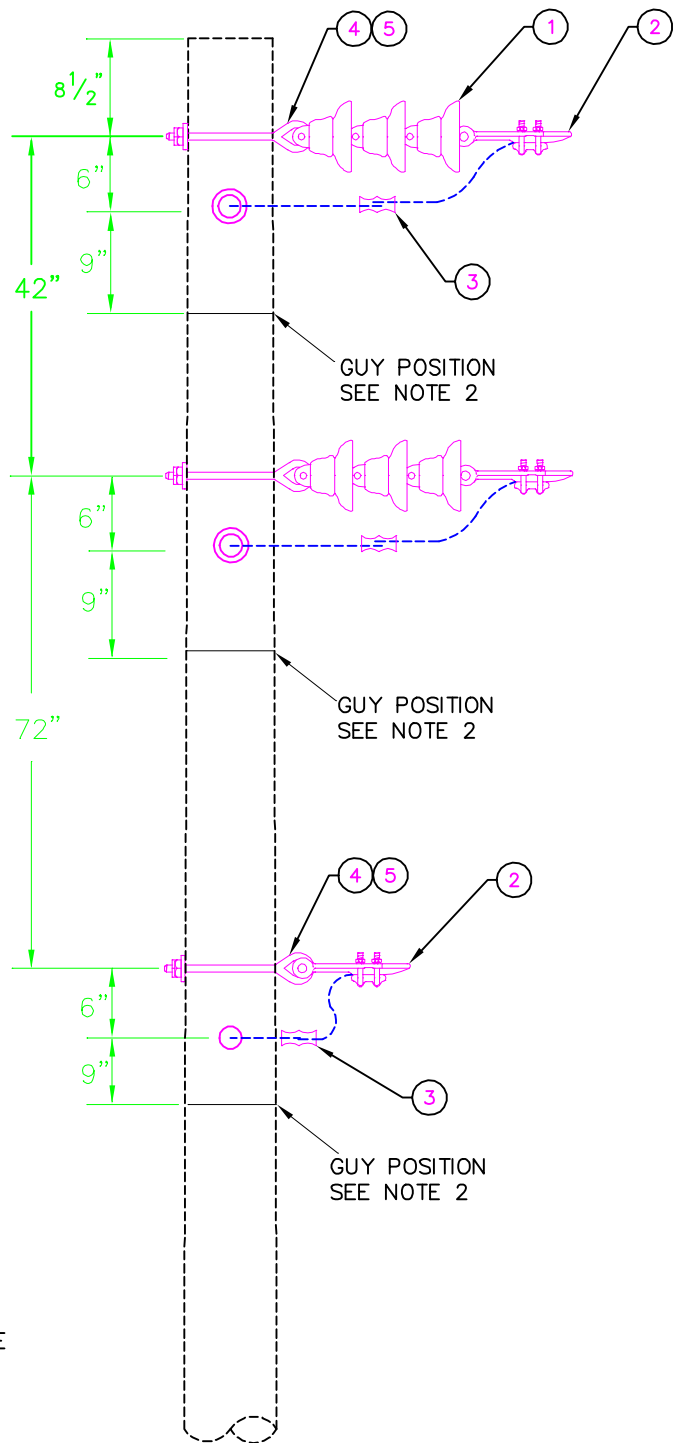

NOTES:

- 1) LINE ANGLE FOR A DOUBLE DEADEND SHOULD BE GREATER THAN 30°.
- 2) SEE DRAWINGS DG-12(14), DG-GG, AND DM-9 FOR INFORMATION AND MATERIALS RELATED TO GUYING AND GROUNDING.

DWG REF	QTY	LIST OF MATERIALS		GREENVILLE UTILITIES COMMISSION GREENVILLE, NORTH CAROLINA				
		DESCRIPTION	STOCK #	 12.47/7.2KV PRIMARY, TWO PHASE LARGE ANGLE, DOUBLE DEADEND SUSPENSION				
1	4	INSULATORS, POLYMER DEAD END BELLS	206920					DWN.
2	6	SHOE, #6 - 1/0 DEAD END	207570	CKD.	KW	APPD.		
3	3	SQUEEZONS, #4	203010	SCALE:	NONE			
4	6	BOLTS, 5/8" x 12" EYE	202290	DATE	REVISION	DATE	REVISION	
5	6	WASHERS, 3 X 3 CURVED	204450					

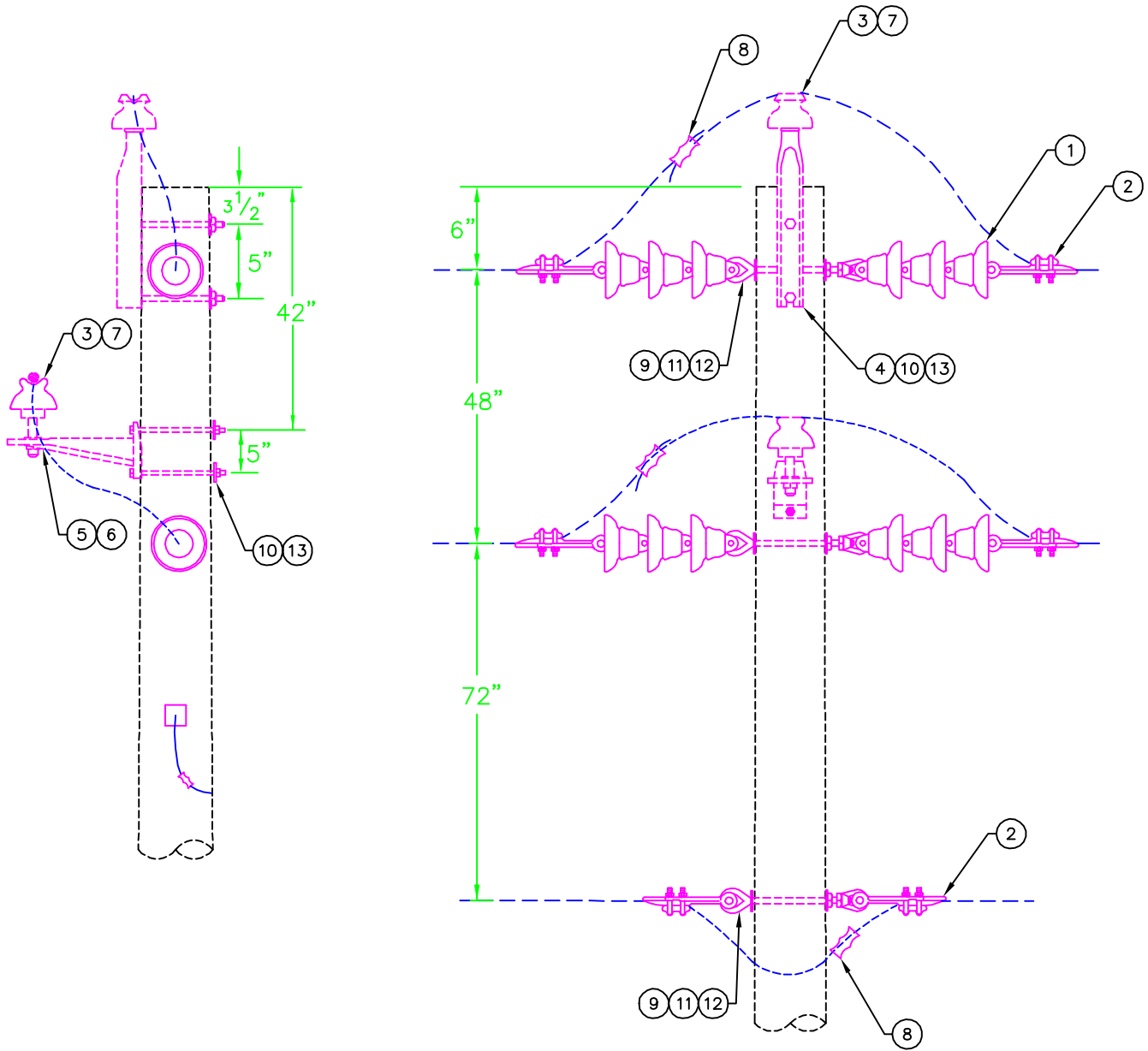

NOTES:

- 1) SEE DRAWINGS DN-GG AND DM-9 FOR INFORMATION AND MATERIALS RELATED TO GUYING AND GROUNDING.

DWG REF	QTY	LIST OF MATERIALS	
		DESCRIPTION	STOCK #
1	4	INSULATORS, POLYMER DEAD END BELLS	206920
2	6	SHOE, #6 - 1/0 DEAD END	207570
3	2	INSULATORS, 15 kV PIN TYPE	203710
4	1	PIN, 18" POLE TOP	203430
5	1	BRACKETS, MIF	203420
6	1	PIN, SHANK	203440
7	2	PREFORMS, 1/0 WRAP TIE	203590
8	3	SQUEEZONS, #4	203010
9	3	BOLTS, 5/8" x 12" EYE	202290
10	4	BOLTS, 5/8" x 12"	202070
11	3	NUTS, 5/8" EYE	204420
12	3	WASHERS, 3 X 3 CURVED	204450
13	4	2 1/4" SQUARE WASHER	204440

GREENVILLE UTILITIES COMMISSION
GREENVILLE, NORTH CAROLINA



12.47/7.2KV PRIMARY, TWO PHASE
TANGENT, DOUBLE DEADEND SUSPENSION

DWN.	JLS	DATE: 08/26/2019	
CKD.	KW	APPD.	
SCALE: NONE			
DATE	REVISION	DATE	REVISION

DWG. NO.

B6

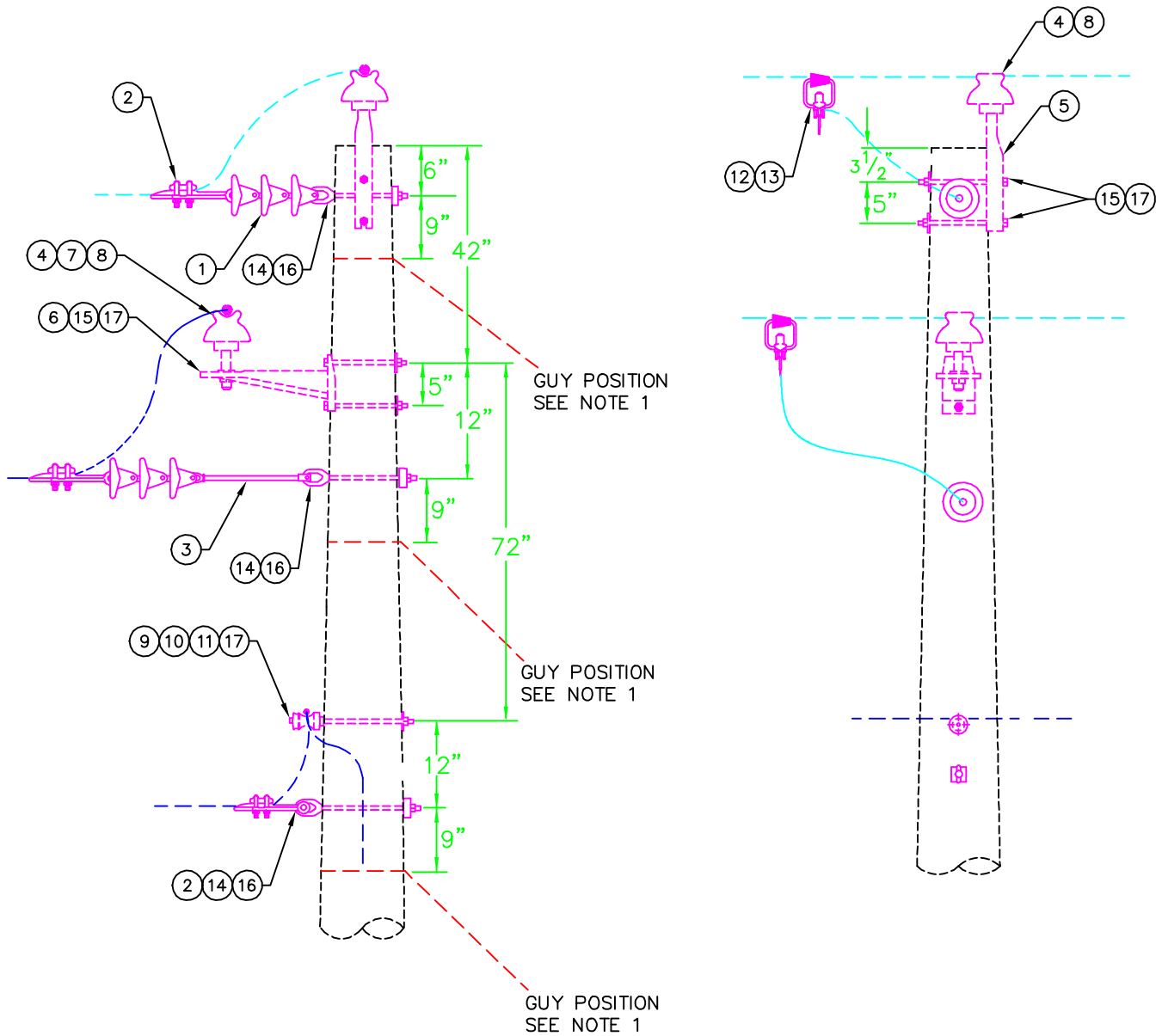

NOTES:

- 1) SEE DRAWINGS DG-12(14), DG-GG, AND DM-9 FOR INFORMATION AND MATERIALS RELATED TO GUYING AND GROUNDING.
- 2) BOND TAP NEUTRAL TO MAIN LINE NEUTRAL AND POLE GROUND. SEE DN-GG FOR DETAILS.

GREENVILLE UTILITIES COMMISSION
GREENVILLE, NORTH CAROLINA



12.47/7.2KV PRIMARY, TWO PHASE
TANGENT WITH TWO PHASE DEAD END TAP

DWG REF	QTY	LIST OF MATERIALS	
		DESCRIPTION	STOCK #
1	2	INSULATORS, POLYMER DEAD END BELLS	206920
2	3	SHOE, #6 - 1/0 DEAD END	207570
3	1	EXTENSION, 14" LINKS	210340
4	1	INSULATORS, 15 kV PIN TYPE	203710
5	1	PIN, 18" POLE TOP	203430
6	1	BRACKETS, MIF	203420
7	1	PIN, SHANK	203440
8	2	PREFORMS, 1/0 WRAP TIE	203590
9	1	INSULATORS, SPOOL "J-151"	208280
10	1	BOLTS, 5/8" x 12" SPOOL	202000
11	1	PREFORMS, 1/0 SPOOL TIE	203650
12	2	CLAMPS, 1/0 SINGLE STIRRUP	202390
13	2	TAPS, HOT LINE CLAMPS	202350
14	3	BOLTS, 5/8" x 12" EYE	202290
15	4	BOLTS, 5/8" x 12"	202070
16	3	WASHERS, 3 X 3 CURVED	204450
17	5	2 1/4" SQUARE WASHER	204440

DWN.	JLS	DATE:	08/26/2019
CKD.	KW	APPD.	
SCALE:	NONE		
DATE	REVISION	DATE	REVISION

DWG. NO.
B7

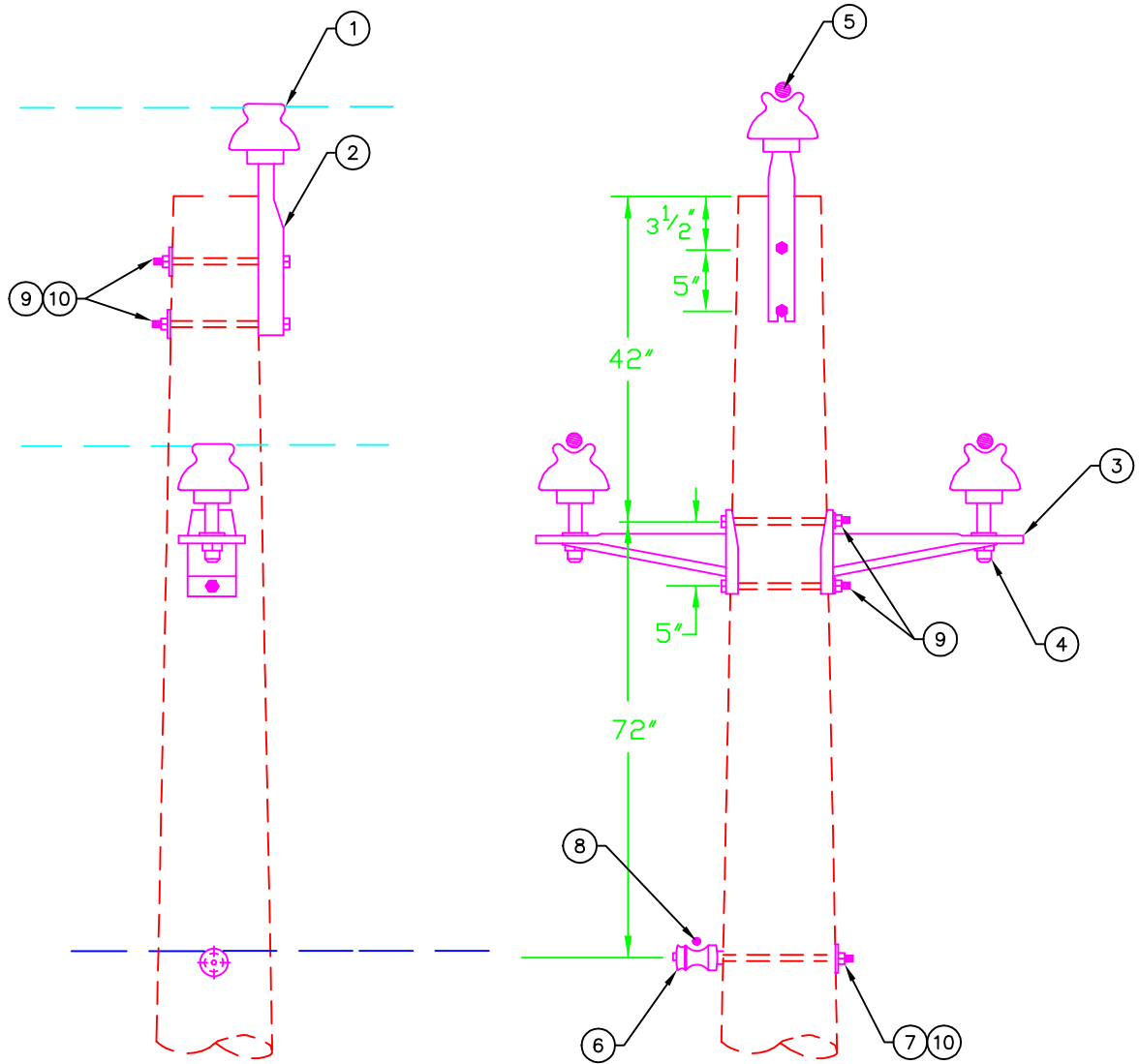

NOTES:

- 1) SEE DRAWINGS DN-GG AND DM-9 FOR INFORMATION AND MATERIALS RELATED GROUNDING.
- 2) MATERIAL VARIES WITH CONDUCTOR SIZE (1/0, 336, AND 795). SEE MATERIALS LIST FOR DETAILS.

DWG REF	QTY	LIST OF MATERIALS	STOCK#
1/0336795		DESCRIPTION	
1	3 3	INSULATORS, 15 kV PIN TYPE	203710
1	- -	INSULATOR, 25 kV POST TYPE	207720
2	1 1	PIN, 18" POLE TOP	203430
2	- -	BRACKET, 35 kV POLE TOP	207890
3	2 2	BRACKETS, MIF	203420
4	2 2	PIN, SHANK	203440
4	- -	BOLTS, 3/4" x 3/4" STUD	210361
5	3 -	PREFORMS, 1/0 WRAP TIE	203590
5	- 3	PREFORMS, 336 WRAP LOCK TIE	203600
5	- -	PREFORMS, 795 WRAP LOCK TIE	203660
6	1 1	INSULATORS, SPOOL "J-151"	208280
7	1 1	BOLTS, 5/8" x 12" SPOOL	202000
8	1 1	PREFORMS, 1/0 SPOOL TIE	203650
8	- -	PREFORMS, 336 SPOOL TIE	207580
9	4 4	BOLTS, 5/8" x 12"	202070
10	3 3	WASHERS, 2 1/4" SQUARE	204440

GREENVILLE UTILITIES COMMISSION
GREENVILLE, NORTH CAROLINA



12.47/7.2KV PRIMARY, THREE PHASE
TANGENT, MIF CONSTRUCTION SINGLE PIN

DWN.	JLS	DATE:	08/27/2019
CKD.	KW	APPD.	
SCALE:	NTS		
DATE	REVISION	DATE	REVISION

DWG. NO.
C1

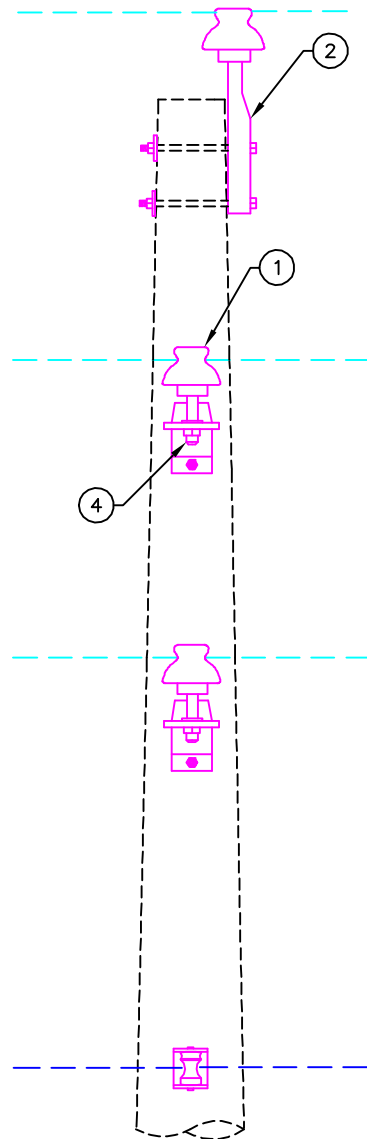
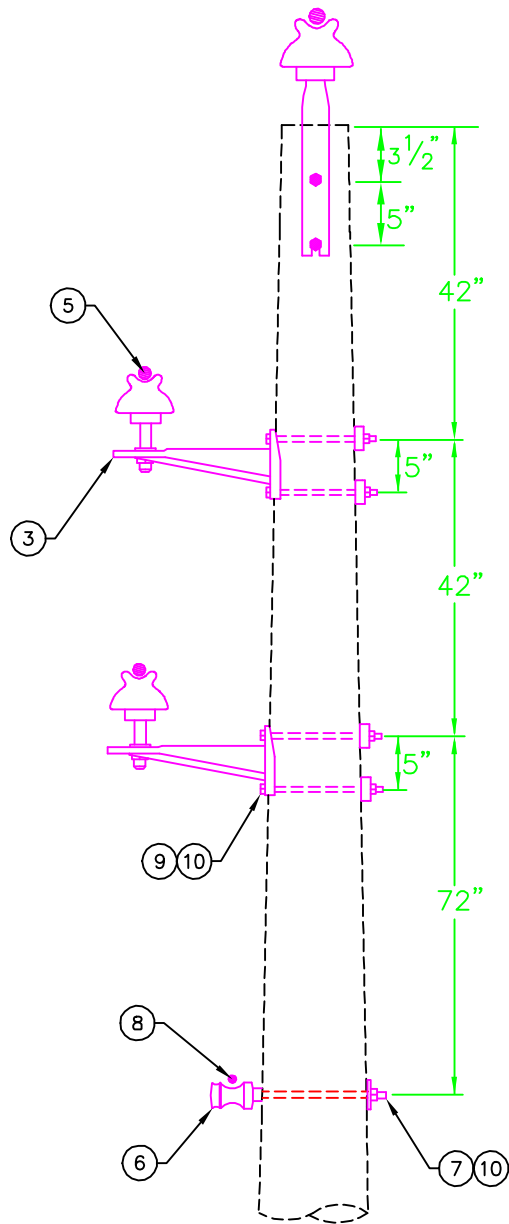

NOTES:

- 1) SEE DRAWINGS DN-GG AND DM-9 FOR INFORMATION AND MATERIALS RELATED GROUNDING.
- 2) MATERIAL VARIES WITH CONDUCTOR SIZE (1/0, 336, AND 795). SEE MATERIALS LIST FOR DETAILS.

DWG REF	QTY			LIST OF MATERIALS DESCRIPTION	STOCK#
	1/0	336	795		
1	3	3	-	INSULATORS, 15 kV PIN TYPE	203710
1	-	-	3	INSULATOR, 25 kV POST TYPE	207720
2	1	1	-	PIN, 18" POLE TOP	203430
2	-	-	1	BRACKET, 35 kV POLE TOP	207890
3	2	2	2	BRACKETS, MIF	203420
4	2	2	-	PIN, SHANK	203440
4	-	-	3	BOLTS, 3/4" x 3/4" STUD	210361
5	3	-	-	PREFORMS, 1/0 WRAP TIE	203590
5	-	3	-	PREFORMS, 336 WRAP LOCK TIE	203600
5	-	-	3	PREFORMS, 795 WRAP LOCK TIE	203660
6	1	1	1	INSULATORS, SPOOL "J-151"	208280
7	1	1	1	BOLTS, 5/8" x 12" SPOOL	202000
8	1	1	-	PREFORMS, 1/0 SPOOL TIE	203650
8	-	-	1	PREFORMS, 336 SPOOL TIE	207580
9	6	6	6	BOLTS, 5/8" x 12"	202070
10	7	7	7	WASHERS, 2 1/4" SQUARE	204440

GREENVILLE UTILITIES COMMISSION
GREENVILLE, NORTH CAROLINA



12.47/7.2KV PRIMARY, THREE PHASE
TANGENT, MIF VERTICAL SINGLE PIN, POLE TOP

DWN.	JLS	DATE: 08/28/2019	
CKD.	KW	APPD.	
SCALE: NTS			
DATE	REVISION	DATE	REVISION

DWG. NO.
C1.V

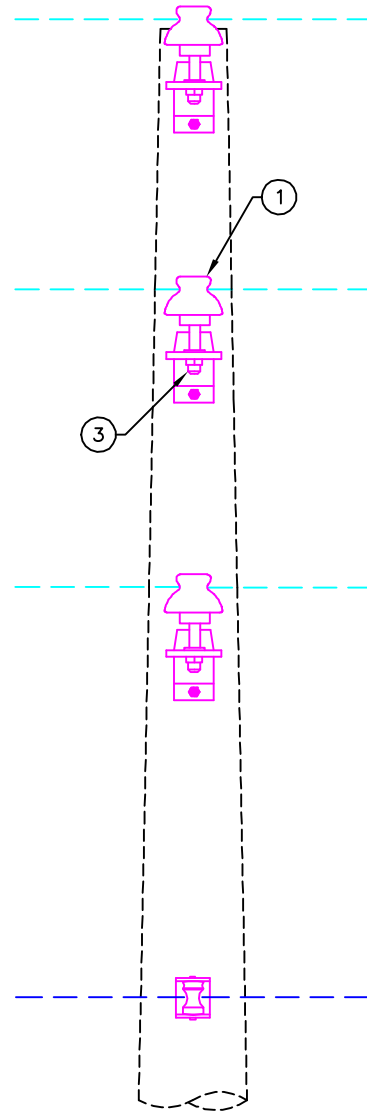
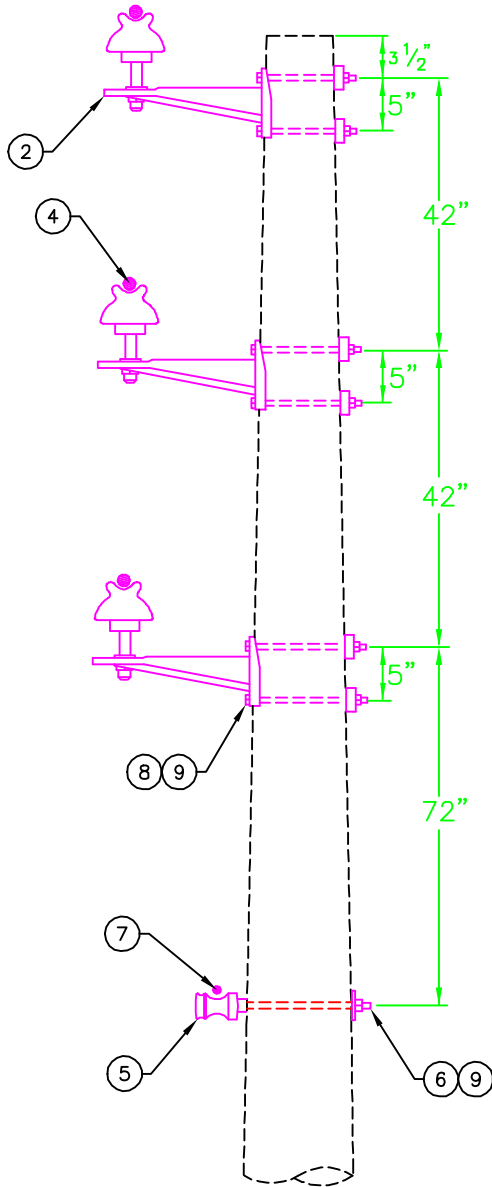

NOTES:

- 1) SEE DRAWINGS DN-GG AND DM-9 FOR INFORMATION AND MATERIALS RELATED GROUNDING.
- 2) MATERIAL VARIES WITH CONDUCTOR SIZE (1/0, 336, AND 795). SEE MATERIALS LIST FOR DETAILS.

DWG REF	QTY	LIST OF MATERIALS	STOCK#	
1/0	336	795		
		DESCRIPTION		
1	3	3	INSULATORS, 15 kV PIN TYPE	203710
1	-	-	INSULATOR, 25 kV POST TYPE	207720
2	3	3	BRACKETS, MIF	203420
3	3	3	PIN, SHANK	203440
3	-	-	BOLTS, 3/4" x 3/4" STUD	210361
4	3	-	PREFORMS, 1/0 WRAP TIE	203590
4	-	3	PREFORMS, 336 WRAP LOCK TIE	203600
4	-	-	PREFORMS, 795 WRAP LOCK TIE	203660
5	1	1	INSULATORS, SPOOL "J-151"	208280
6	1	1	BOLTS, 5/8" x 12" SPOOL	202000
7	1	1	PREFORMS, 1/0 SPOOL TIE	203650
7	-	-	PREFORMS, 336 SPOOL TIE	207580
8	6	6	BOLTS, 5/8" x 12"	202070
9	7	7	WASHERS, 2 1/4" SQUARE	204440

GREENVILLE UTILITIES COMMISSION
GREENVILLE, NORTH CAROLINA



12.47/7.2KV PRIMARY, THREE PHASE
TANGENT, MIF VERTICAL SINGLE PIN

DWN.	JLS	DATE:	08/28/2019
CKD.	KW	APPD.	
SCALE:	NTS		
DATE	REVISION	DATE	REVISION

DWG. NO.
C1.V1

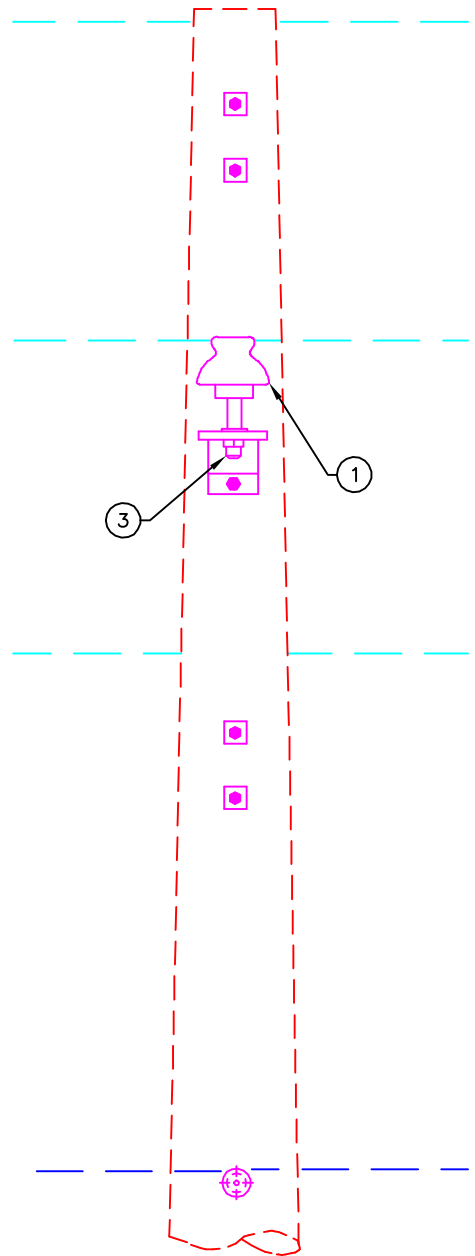
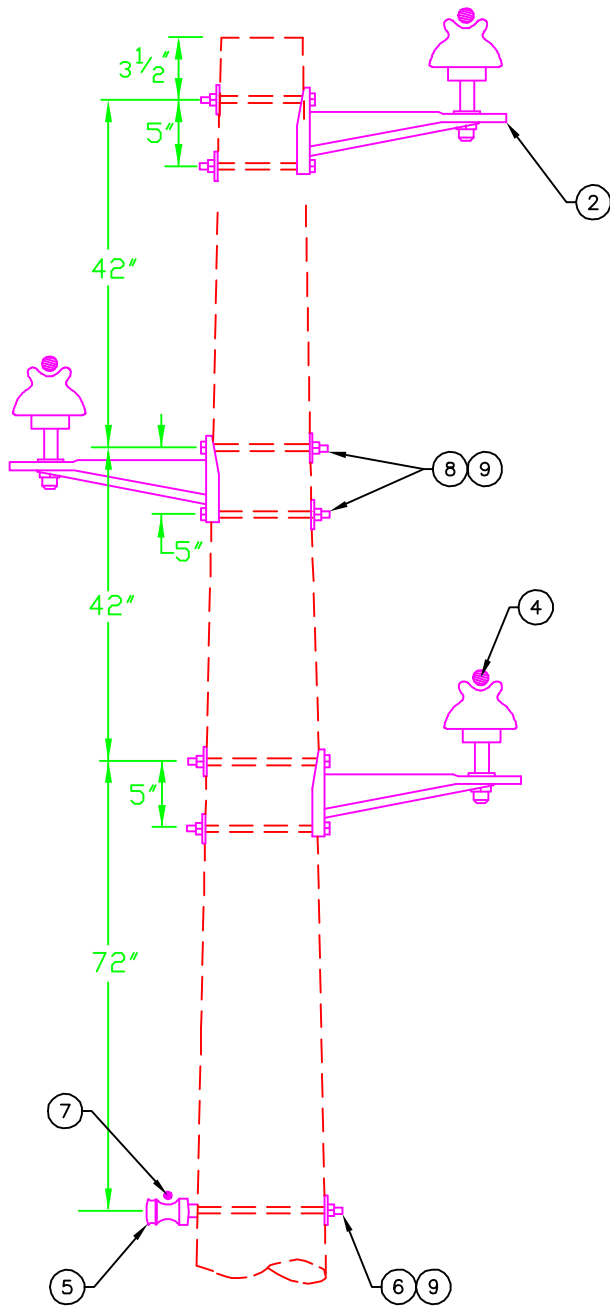

NOTES:

- 1) SEE DRAWINGS DN-GG AND DM-9 FOR INFORMATION AND MATERIALS RELATED GROUNDING.
- 2) MATERIAL VARIES WITH CONDUCTOR SIZE (1/0, 336, AND 795). SEE MATERIALS LIST FOR DETAILS.

DWG REF	QTY			LIST OF MATERIALS	
	1/0	336	795	DESCRIPTION	STOCK#
1	3	3	-	INSULATORS, 15 kV PIN TYPE	203710
1	-	-	3	INSULATOR, 25 kV POST TYPE	207720
2	3	3	3	BRACKETS, MIF	203420
3	3	3	-	PIN, SHANK	203440
3	-	-	3	BOLTS, 3/4" x 3/4" STUD	210361
4	3	-	-	PREFORMS, 1/0 WRAP TIE	203590
4	-	3	-	PREFORMS, 336 WRAP LOCK TIE	203600
4	-	-	3	PREFORMS, 795 WRAP LOCK TIE	203660
5	1	1	1	INSULATORS, SPOOL "J-151"	208280
6	1	1	1	BOLTS, 5/8" x 12" SPOOL	202000
7	1	1	-	PREFORMS, 1/0 SPOOL TIE	203650
7	-	-	1	PREFORMS, 336 SPOOL TIE	207580
8	6	6	6	BOLTS, 5/8" x 12"	202070
9	7	7	7	WASHERS, 2 1/4" SQUARE	204440

GREENVILLE UTILITIES COMMISSION
GREENVILLE, NORTH CAROLINA



12.47/7.2KV PRIMARY, THREE PHASE
TANGENT, MIF Z CONSTRUCTION SINGLE PIN

DWN.	JLS	DATE: 08/28/2019	
CKD.	KW	APPD.	
SCALE:		NTS	
DATE	REVISION	DATE	REVISION

DWG. NO.
C1.Z

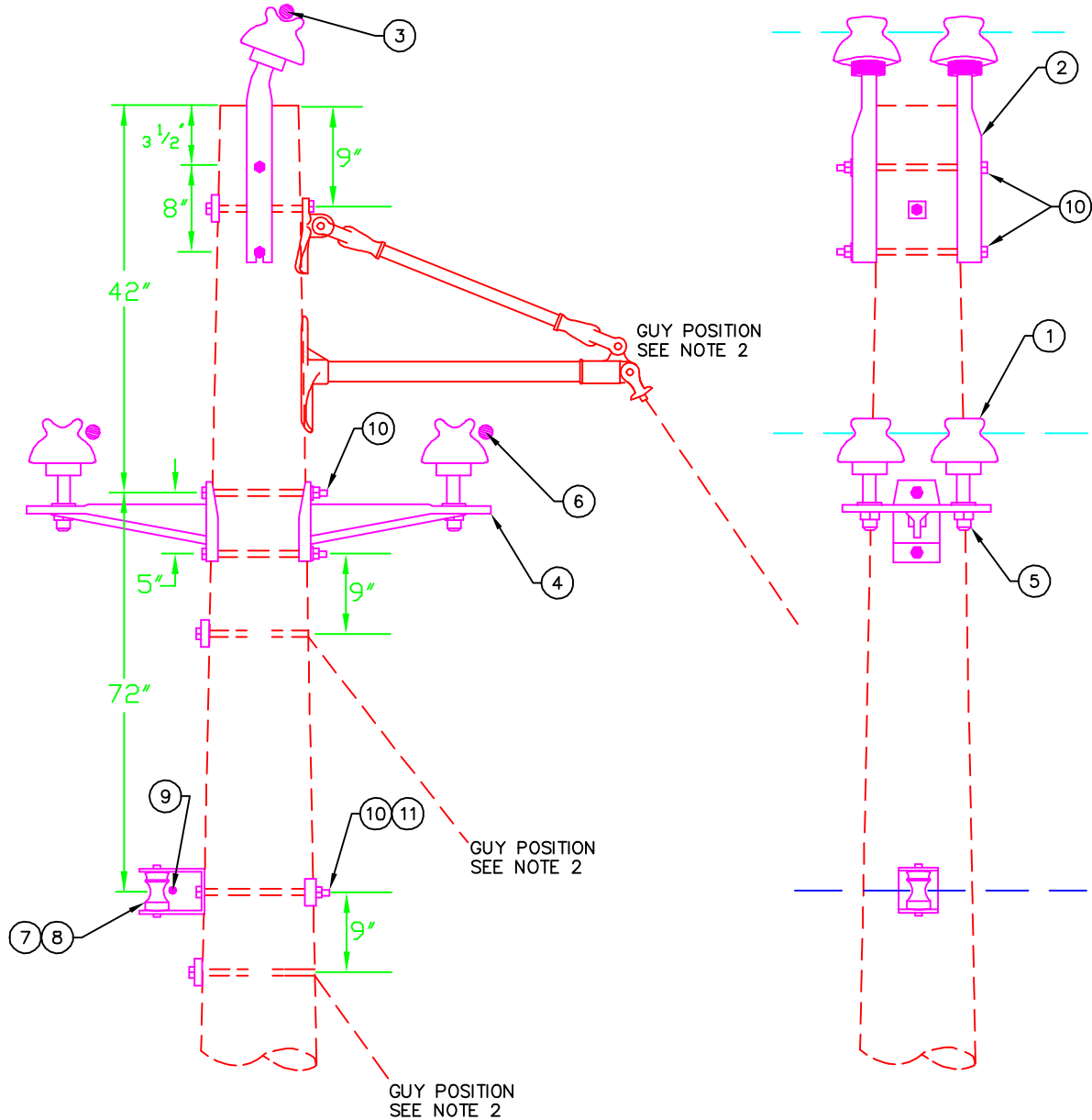

NOTES:

- 1) LINE ANGLE FOR A DOUBLE PIN INSULATOR SHOULD BE (1°-12°).
- 2) SEE DRAWINGS SWG-12(14), DG-12(14), DG-GG, AND DM-9 FOR INFORMATION AND MATERIALS RELATED TO GUYING AND GROUNDING.
- 3) MATERIAL VARIES WITH CONDUCTOR SIZE (1/0, 336, AND 795). SEE MATERIALS LIST FOR DETAILS

DWG REF	QTY	LIST OF MATERIALS	STOCK#
	1/0336795	DESCRIPTION	
1	6 6	INSULATORS, 15 kV PIN TYPE	203710
1	- -	6 INSULATOR, 25 kV POST TYPE	207720
2	2 2	PIN, 18" POLE TOP	203430
2	- -	2 BRACKET, 35 kV POLE TOP	207890
3	1 -	- PREFORMS, 1/0 DOUBLE SUPPORT	203580
3	- 1	- PREFORMS, 336 DOUBLE SUPPORT TIE	203570
3	- -	1 PREFORMS, 795 DOUBLE SUPPORT TIE	203670
4	2 2	2 BRACKETS, MIF	203420
5	4 4	- PIN, SHANK	203440
5	- -	6 BOLTS, 3/4" x 3/4" STUD	210361
6	2 -	- PREFORMS, 1/0 DOUBLE SIDE TIE	203540
6	- 2	- PREFORMS, 336 DOUBLE SIDE TIE	203550
6	- -	2 PREFORMS, 795 DOUBLE SIDE TIE	207800
7	1 1	1 INSULATORS, SPOOL "J-151"	208280
8	1 1	1 CLEVIS, 1342	208290
9	1 1	- PREFORMS, 1/0 SPOOL TIE	203650
9	- -	1 PREFORMS, 336 SPOOL TIE	207580
10	5 5	5 BOLTS, 5/8" x 12"	202070
11	1 1	1 WASHERS, 3 X 3 CURVED	204450

GREENVILLE UTILITIES COMMISSION
GREENVILLE, NORTH CAROLINA



12.47/7.2KV PRIMARY, THREE PHASE
SMALL ANGLE, MIF CONSTRUCTION DOUBLE PIN

DWN.	JLS	DATE:	08/28/2019
CKD.	KW	APPD.	
SCALE:	NTS		
DATE	REVISION	DATE	REVISION

DWG. NO.
C2

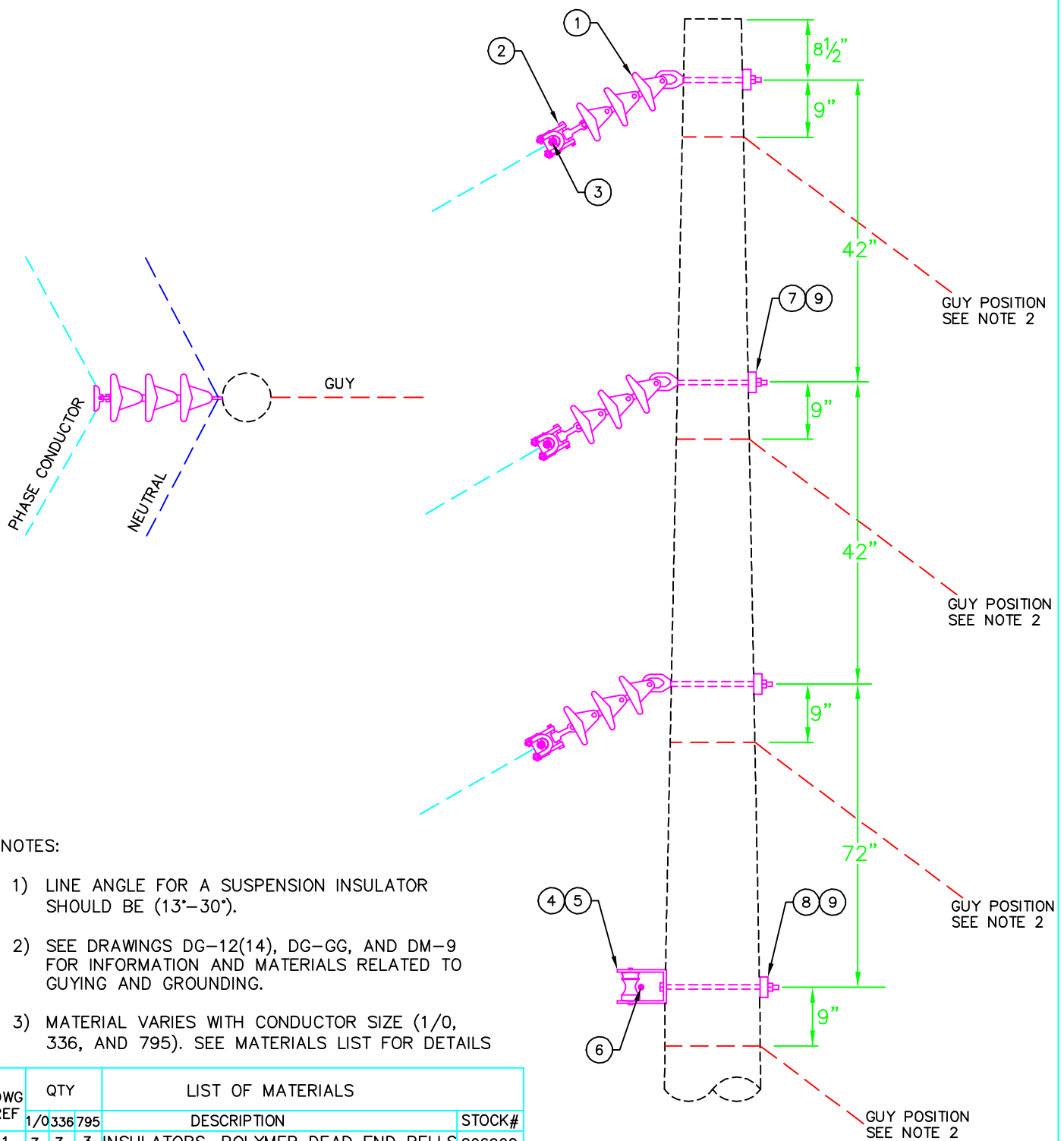

NOTES:

- 1) LINE ANGLE FOR A SUSPENSION INSULATOR SHOULD BE (13°-30°).
- 2) SEE DRAWINGS DG-12(14), DG-GG, AND DM-9 FOR INFORMATION AND MATERIALS RELATED TO GUYING AND GROUNDING.
- 3) MATERIAL VARIES WITH CONDUCTOR SIZE (1/0, 336, AND 795). SEE MATERIALS LIST FOR DETAILS

DWG REF	QTY	LIST OF MATERIALS	STOCK#	
1/0	336	795		
1	3	3	INSULATORS, POLYMER DEAD END BELLS	206920
2	3	-	CLAMPS, 1/0 SUSPENSION	202420
2	-	3	CLAMPS, 336 SUSPENSION	202400
2	-	3	CLAMPS, 795 SUSPENSION	202430
3	3	-	RODS, 1/0 ARMOR	201960
3	-	3	RODS, 336 ARMOR	201980
3	-	3	RODS, 795 ARMOR	207740
4	1	1	INSULATORS, SPOOL "J-151"	208280
5	1	1	CLEVIS, 1342	208290
6	1	1	PREFORMS, 1/0 SPOOL TIE	203650
6	-	-	PREFORMS, 336 SPOOL TIE	207580
7	3	3	BOLTS, 5/8" x 12" EYE	202290
8	1	1	BOLTS, 5/8" x 12"	202070
9	4	4	WASHERS, 3 X 3 CURVED	204450

GREENVILLE UTILITIES COMMISSION
GREENVILLE, NORTH CAROLINA



12.47/7.2KV PRIMARY, THREE PHASE
LARGE ANGLE, SUSPENSION INSULATOR

DWN.	JLS	DATE:	09/03/2019
CKD.	KW	APPD.	
SCALE:	NTS		
DATE	REVISION	DATE	REVISION

DWG. NO.
C3

GUY POSITION

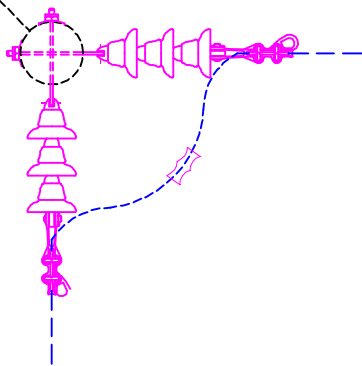

PLAN VIEW

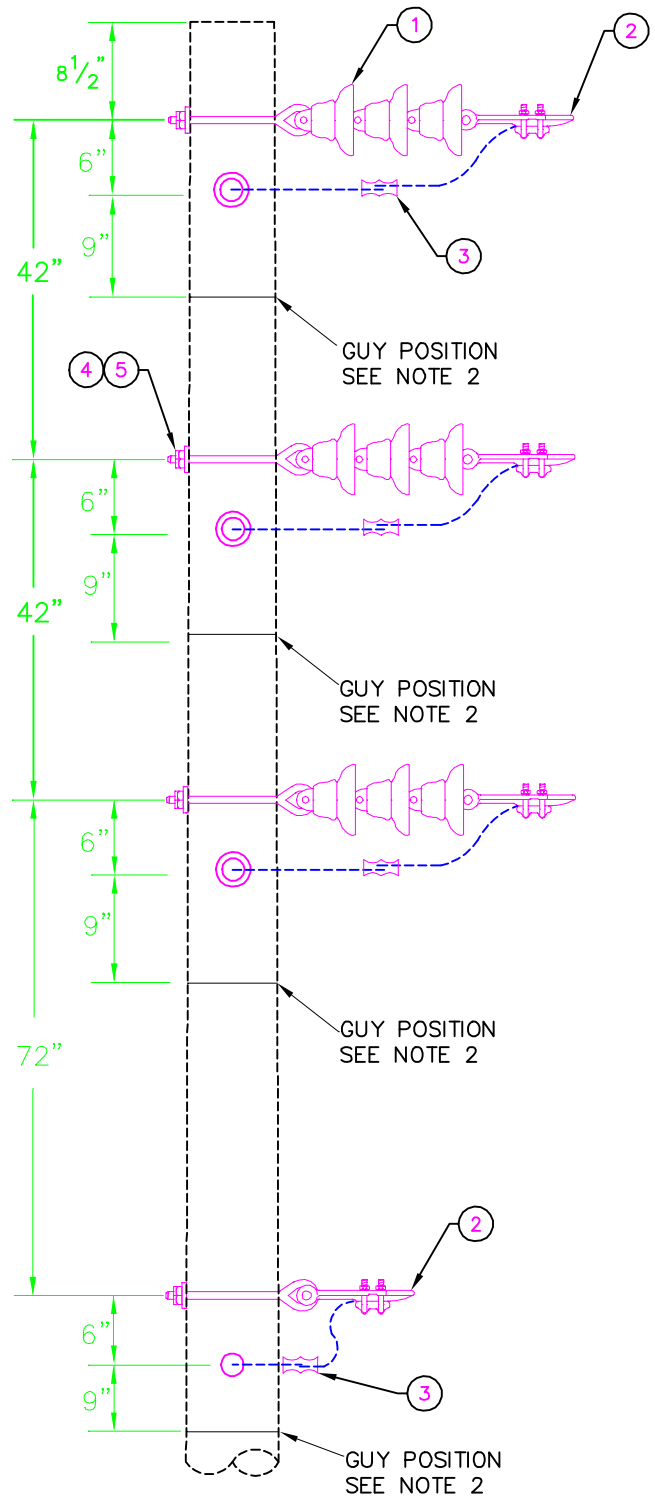

NOTES:

- 1) LINE ANGLE FOR A DOUBLE DEADEND SHOULD BE GREATER THAN 30°.
- 2) SEE DRAWINGS DG-12(14), DG-GG, AND DM-9 FOR INFORMATION AND MATERIALS RELATED TO GUYING AND GROUNDING.
- 3) MATERIAL VARIES WITH CONDUCTOR SIZE (1/0, 336, AND 795). SEE MATERIALS LIST FOR DETAILS.

DWG REF	QTY	LIST OF MATERIALS	STOCK #		
1/0336795		DESCRIPTION			
1	6	6	INSULATORS, POLYMER DEAD END BELLS	206920	
2	8	2	SHOE, #6 - 1/0 DEAD END	207570	
2	-	6	SHOE, 336 DEAD END	202450	
2	-	6	SHOE, 795 DEAD END	202440	
3	4	1	SQUEEZONS, #4	203010	
3	-	3	1	CONN., 602007 AMPACT 336-336	202880
3	-	3	CONN., 795-795 AMPACT	202940	
4	8	8	8	BOLTS, 5/8" X 12" EYE	202290
5	8	8	8	WASHERS, 3 X 3 CURVED	204450

GREENVILLE UTILITIES COMMISSION
GREENVILLE, NORTH CAROLINA



12.47/7.2KV PRIMARY, THREE PHASE
LARGE ANGLE, DOUBLE DEADEND SUSPENSION

DWN.	JLS	DATE:	09/03/2019
CKD.	KW	APPD.	
SCALE:	NONE		
DATE	REVISION	DATE	REVISION

DWG. NO.

C4

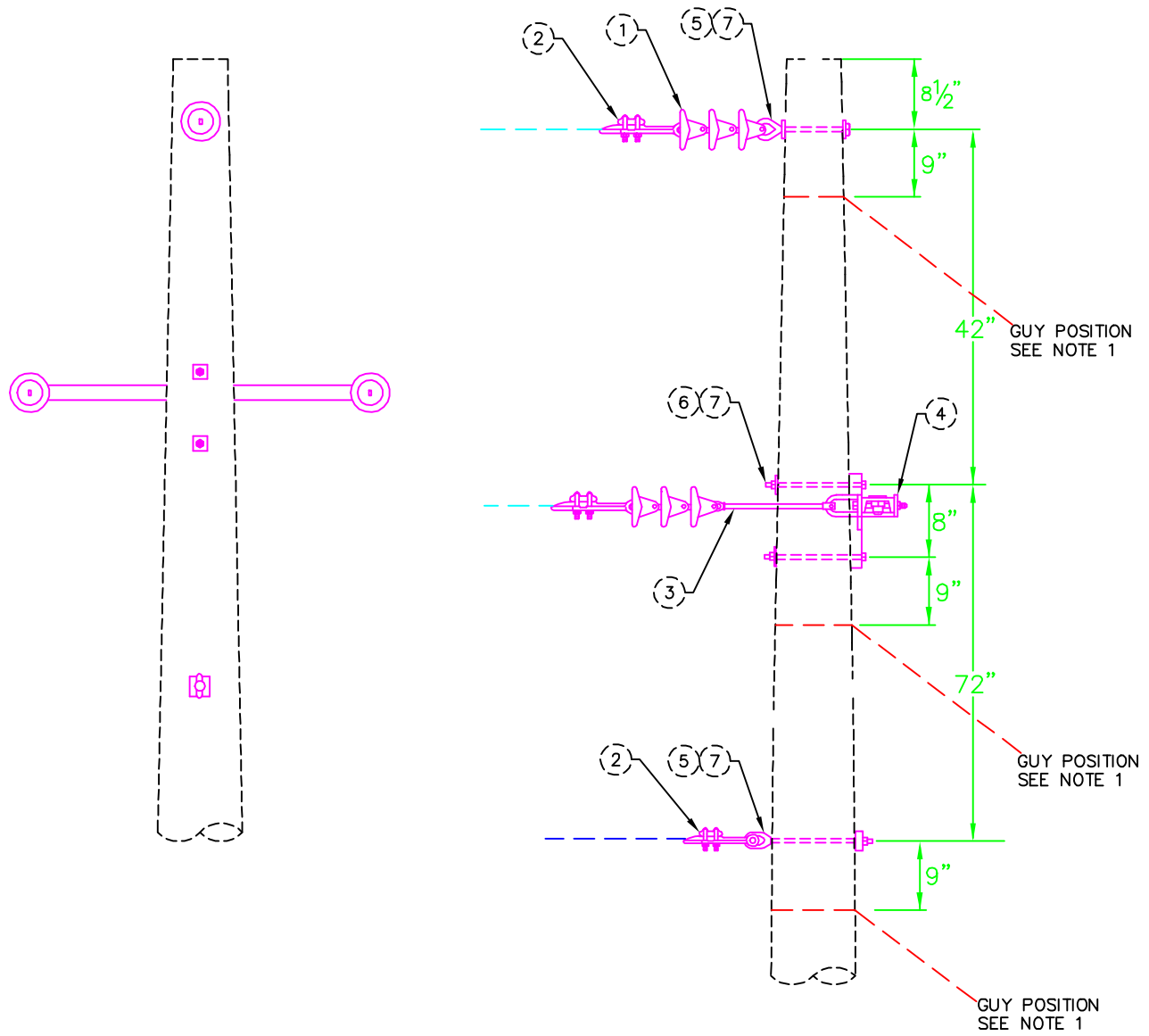

NOTES:

- 1) SEE DRAWINGS DG-12(14), DG-GG, AND DM-9 FOR INFORMATION AND MATERIALS RELATED TO GUYING AND GROUNDING.
- 2) MATERIAL VARIES WITH CONDUCTOR SIZE (1/0, 336, AND 795). SEE MATERIALS LIST FOR DETAILS.

DWG REF	QTY	LIST OF MATERIALS	STOCK #	GREENVILLE UTILITIES COMMISSION GREENVILLE, NORTH CAROLINA				
	1/0 336 795	DESCRIPTION		 12.47/7.2KV PRIMARY, THREE PHASE SINGLE DEADEND, CROSSARM SUSPENSION				
1	3 3 3	INSULATORS, POLYMER DEAD END BELLS	206920	DWN.	JLS	DATE: 09/03/2019		DWG. NO. C5
2	4 1 -	SHOE, #6 - 1/0 DEAD END	207570	CKD.	KW	APPD.		
2	- 3 1	SHOE, 336 DEAD END	202450	SCALE:	NONE			
2	- - 3	SHOE, 795 DEAD END	202440	DATE	REVISION	DATE	REVISION	
3	2 2 2	EXTENSIONS, 14" LINKS	210340					
4	1 1 1	ARMS, STEEL DEAD END CROSS	203800					
5	2 2 2	BOLTS, 5/8" x 12" EYE	202290					
6	2 2 2	BOLTS, 3/4" x 12"	202230					
7	4 4 4	WASHERS, 3 X 3 CURVED	204450					

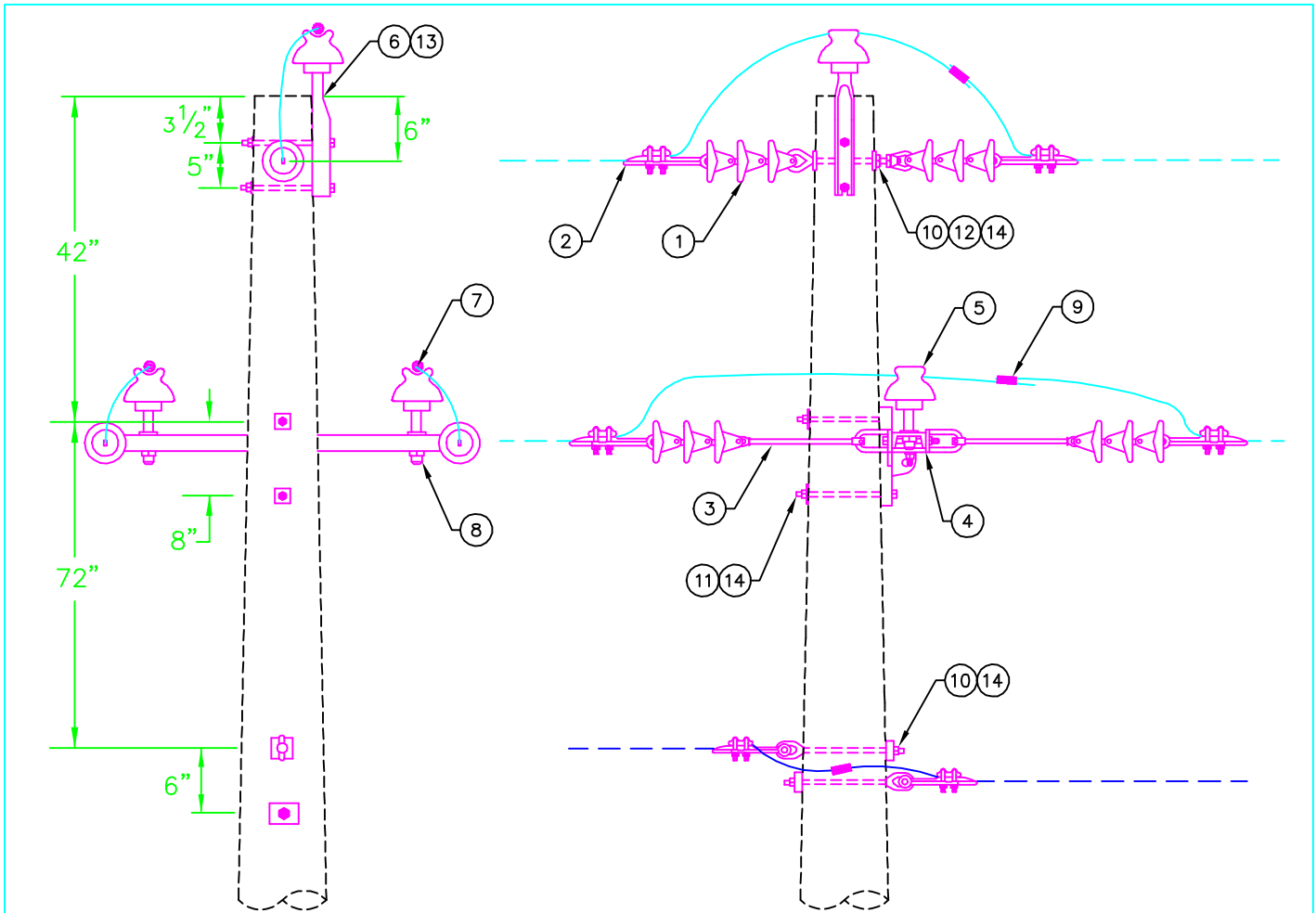

DWG REF	QTY	LIST OF MATERIALS	STOCK#
1	6 6 6	INSULATORS, POLYMER DEAD END BELLS	203710
2	8 2	SHOE, #6 - 1/0 DEAD END	207570
2	- 6 2	SHOE, 336 DEAD END	202450
2	- - 6	SHOE, 795 DEAD END	202440
3	4 4 4	EXTENSIONS, 14" LINKS	210340
4	1 1 1	ARMS, STEEL DEAD END CROSS	203800
5	3 3	INSULATORS, 15 kV PIN TYPE	203710
5	- - 3	INSULATOR, 25 kV POST TYPE	207720
6	1 1	PIN, 18" POLE TOP	203430
6	- - 1	BRACKET, 35 kV POLE TOP	207890
7	3 - -	PREFORMS, 1/0 WRAP TIE	203590
7	- 3 -	PREFORMS, 336 WRAP LOCK TIE	203600
7	- - 3	PREFORMS, 795 WRAP LOCK TIE	203660
8	2 2	PINS, LONG SHANK CROSS ARM	210311
8	- - 2	PINS, 35 kV CROSS	-
9	4 1	SQUEEZONS, #4	203010
9	- 3 1	CONN., 602007 AMPACT 336-336	202880
9	- - 3	CONN., 795-795 AMPACT	202940
10	3 3 3	BOLTS, 5/8" x 12" EYE	202290
11	2 2 2	BOLTS, 3/4" x 12"	202230
12	1 1 1	NUTS, 5/8" EYE	204420
13	- - 1	BOLTS, 3/4" x 3/4" STUD	210361
14	5 5 5	WASHERS, 3 X 3 CURVED	204450

NOTES:

- 1) SEE DRAWINGS DN-GG AND DM-9 FOR INFORMATION AND MATERIALS RELATED TO GUYING AND GROUNDING.
- 2) MATERIAL VARIES WITH CONDUCTOR SIZE (1/0, 336, AND 795). SEE MATERIALS LIST FOR DETAILS.

GREENVILLE UTILITIES COMMISSION
GREENVILLE, NORTH CAROLINA



12.47/7.2KV PRIMARY, THREE PHASE
TANGENT DOUBLE DEADEND, CROSS. SUSPEN.

DWN.	JLS	DATE:	09/04/2019
CKD.	KW	APPD.	
SCALE:	NTS		
DATE	REVISION	DATE	REVISION

DWG. NO.
C6

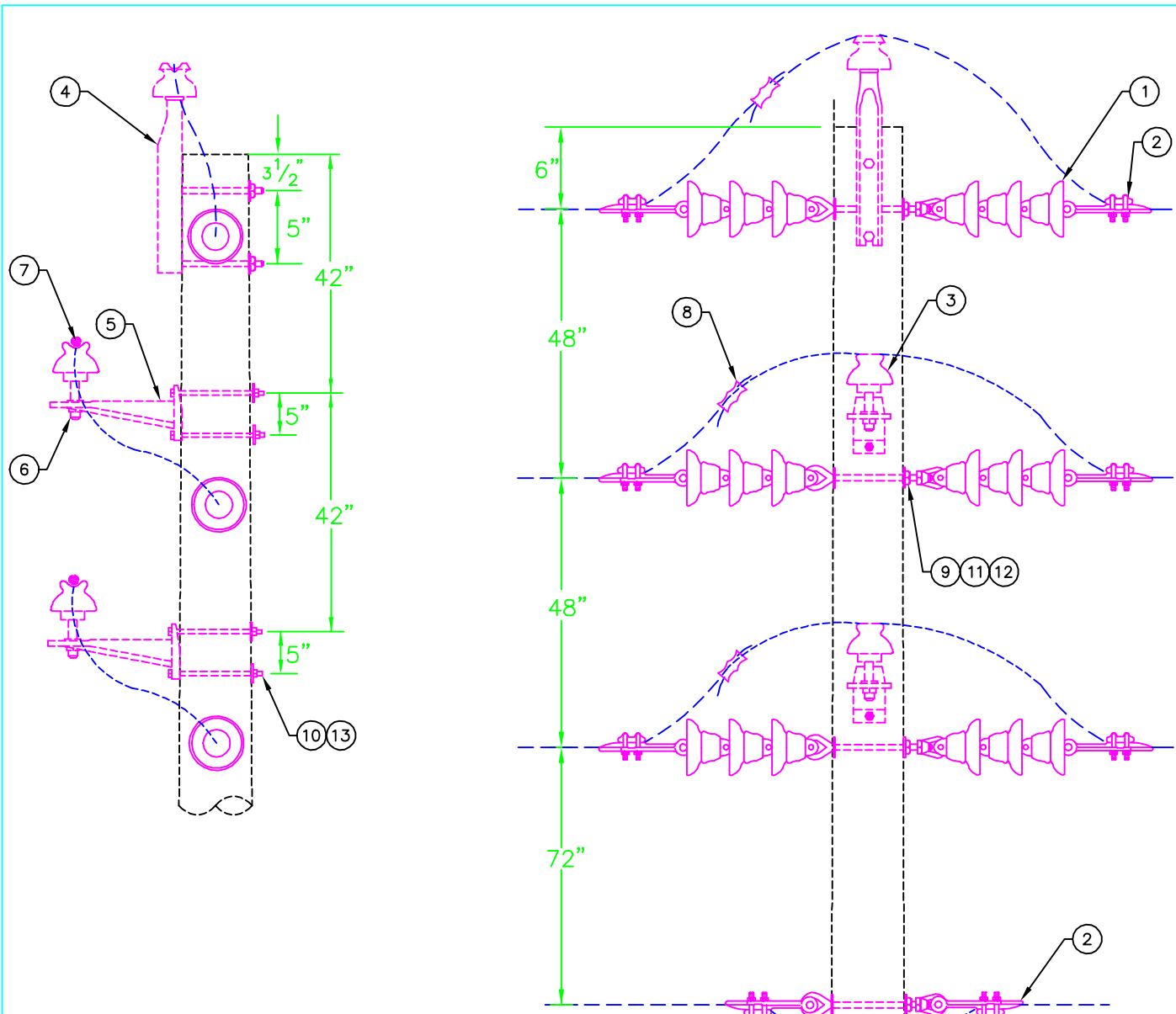

DWG REF	QTY	LIST OF MATERIALS DESCRIPTION	STOCK#
1	6	6 INSULATORS, POLYMER DEAD END BELLS	203710
2	8	2 - SHOE, #6 - 1/0 DEAD END	207570
2	-	6 2 SHOE, 336 DEAD END	202450
2	-	6 SHOE, 795 DEAD END	202440
3	3	3 - INSULATORS, 15 kV PIN TYPE	203710
3	-	3 INSULATOR, 25 kV POST TYPE	207720
4	1	1 - PIN, 18" POLE TOP	203430
4	-	1 BRACKET, 35 kV POLE TOP	207890
5	1	1 BRACKETS, MIF	203420
6	2	2 - PIN, SHANK	203440
6	-	3 BOLTS, 3/4" x 3/4" STUD	210361
7	3	- PREFORMS, 1/0 WRAP TIE	203590
7	-	3 - PREFORMS, 336 WRAP LOCK TIE	203600
7	-	3 PREFORMS, 795 WRAP LOCK TIE	203660
8	4	1 - SQUEEZONS, #4	203010
8	-	3 1 CONN., 602007 AMPACT 336-336	202880
8	-	3 CONN., 795-795 AMPACT	202940
9	4	4 BOLTS, 5/8" x 12" EYE	202290
10	6	6 BOLTS, 5/8" x 12"	202070
11	4	4 NUTS, 5/8" EYE	204420
12	3	3 WASHERS, 3 X 3 CURVED	204450
13	5	5 2 1/4" SQUARE WASHER	204440

NOTES:

- 1) SEE DRAWINGS DN-GG AND DM-9 FOR INFORMATION AND MATERIALS RELATED TO GUYING AND GROUNDING.

GREENVILLE UTILITIES COMMISSION
GREENVILLE, NORTH CAROLINA



12.47/7.2KV PRIMARY, THREE PHASE
TANGENT, DOUBLE DEADEND SUSPENSION

DWN.	JLS	DATE:	09/04/2019
CKD.	KW	APPD.	
SCALE:	NONE		
DATE	REVISION	DATE	REVISION

DWG. NO.
C6.V

Appendix C: Standard Assembly Drawings

[Balance of Page Left Blank Intentionally]

SIDE VIEW

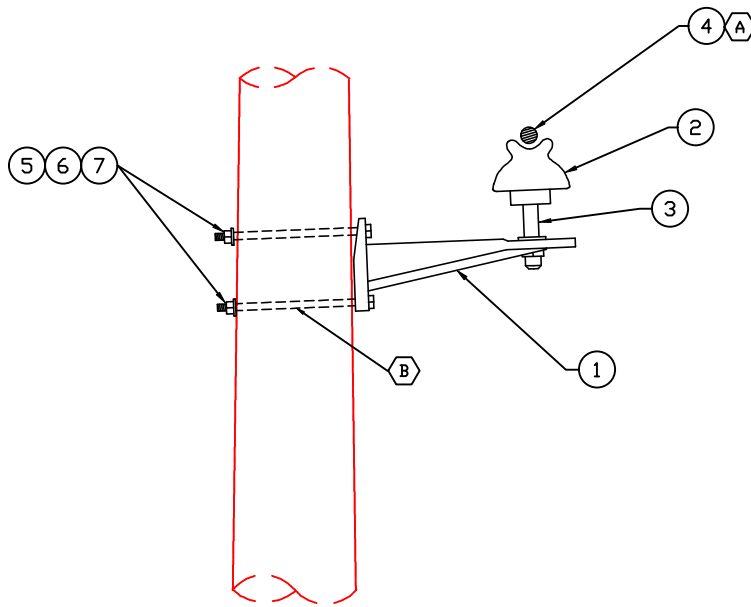

NOTES:

- (A) SELECT INSULATOR & WRAP LOCK APPROPRIATE FOR WIRE SIZE.
- (B) SELECT BOLT LENGTH APPROPRIATE FOR POLE DIAMETER

DWG. REF.	QTY	LIST OF MATERIALS	GREENVILLE UTILITIES COMMISSION GREENVILLE, NORTH CAROLINA				
		DESCRIPTION	 MIF BRACKET ASSEMBLY				
1	1	BRACKET, 18" FIBERGLASS					DWN. DRB CKD. JLS SCALE: N.T.S. DATE
2	1	INSULATOR, PIN TYPE	APPD. JLS				
3	1	PIN SHANK					
4	1	PREFORM, WRAP LOCK					
5	2	BOLT, MACHINE 5/8" REQUIRED LENGTH					
6	2	WASHERS, 2 1/4" SQUARE					
7	2	SPRING LOCK WASHER 5/8"					
					REVISION		

SIDE VIEW

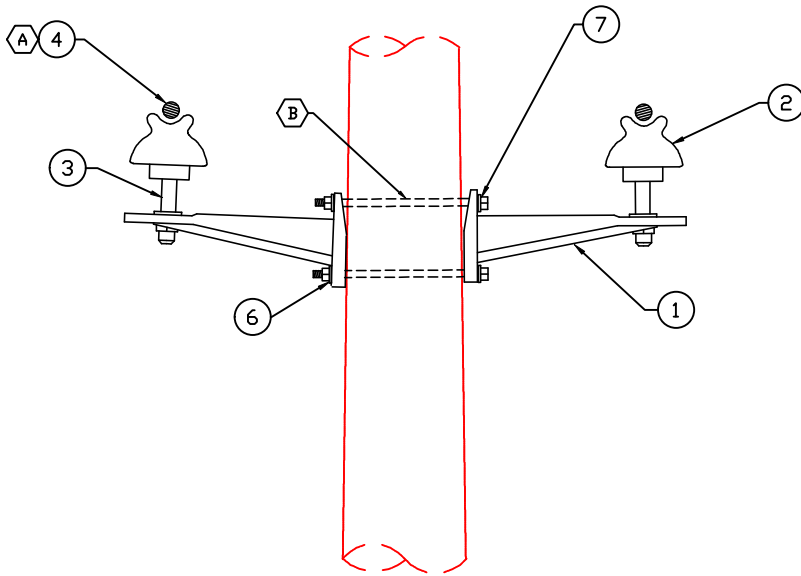

NOTES:

- (A) SELECT INSULATOR & WRAP LOCK APPROPRIATE FOR WIRE SIZE.
- (B) SELECT BOLT LENGTH APPROPRIATE FOR POLE DIAMETER

DWG. REF.	QTY	LIST OF MATERIALS	GREENVILLE UTILITIES COMMISSION GREENVILLE, NORTH CAROLINA			
		DESCRIPTION	 DOUBLE MIF BRACKET ASSEMBLY			
1	2	BRACKET, 18" FIBERGLASS				
2	2	INSULATOR, PIN TYPE				
3	2	PIN SHANK				
4	2	PREFORM, WRAP LOCK				
5	2	BOLT, MACHINE 5/8" REQUIRED LENGTH				
6	2	SPRING LOCK WASHER 5/8"				
			DATE	REVISION		

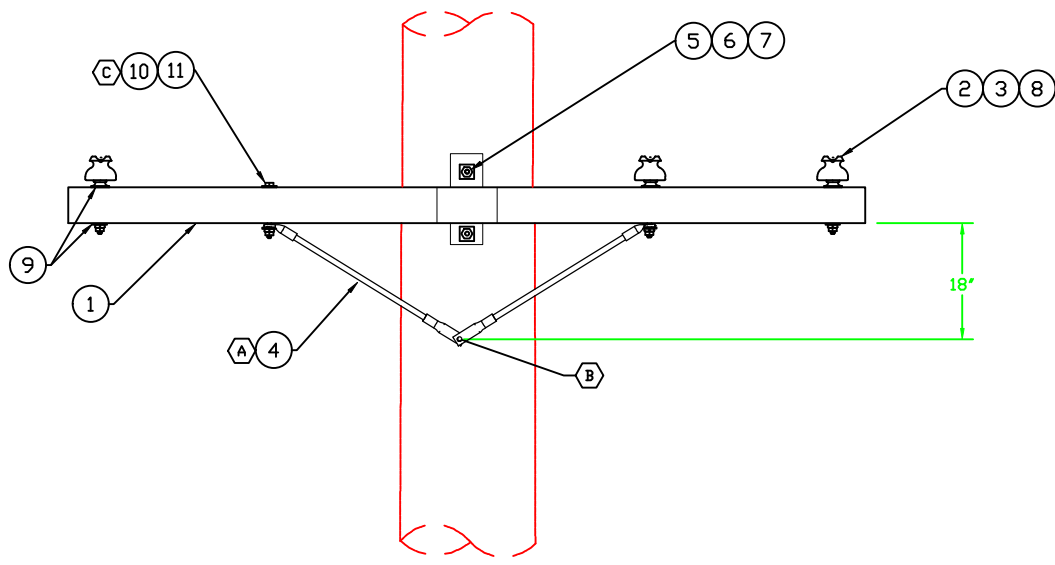

SIDE VIEW

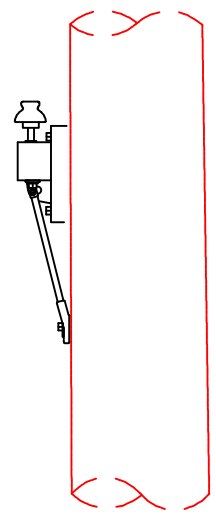

NOTES:

- 1) INSULATOR ITEM(2) & ITEM(3) WILL VARY BASED ON WIRE SIZE.
- (A) MOUNT BRACE USING EXISTING HOLES IN CROSSARM.
- (B) HOLE TO BE FIELD DRILLED AT SPECIFIED LOCATION.
- (C) INSTALL 3 X 3 SQUARE WASHER, ITEM(9), ON TOP AND BOTTOM OF CROSSARM.

DWG. REF.	XRM-10A QTY	LIST OF MATERIALS DESCRIPTION
1	1	ARMS, 10' H/T FIBERGLASS
2	3	PIN INSULATOR
3	3	PREFORMS, WRAP LOCK
4	1	CROSSARM BRACE
5	3	BOLT, MACHINE 5/8" X LENGTH"
6	3	SPRING LOCK WASHER, 5/8"
7	3	WASHER, SQ. 4 X 4 X 13/16"
8	3	CROSSARM PINS
9	8	3 X 3 SQUARE WASHERS
10	1	5/8" x 8" BOLT
11	1	5/8" LOCK WASHER

GREENVILLE UTILITIES COMMISSION GREENVILLE, NORTH CAROLINA	
	10' TANGENT DISTRIBUTION CROSSARM
DWN. DRB	DATE: 5/27/2022
CKD. JLS	APPD. JLS
SCALE: N.T.S.	
DATE	DATE
	REVISION

DWG. NO.
XRM-10A

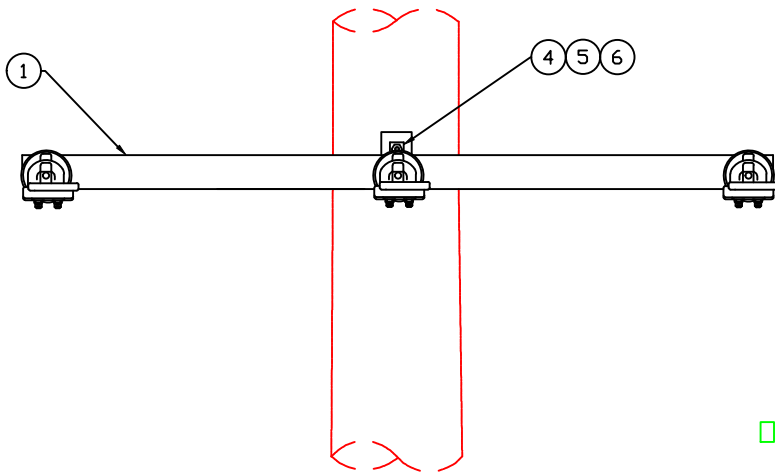

OVERHEAD VIEW

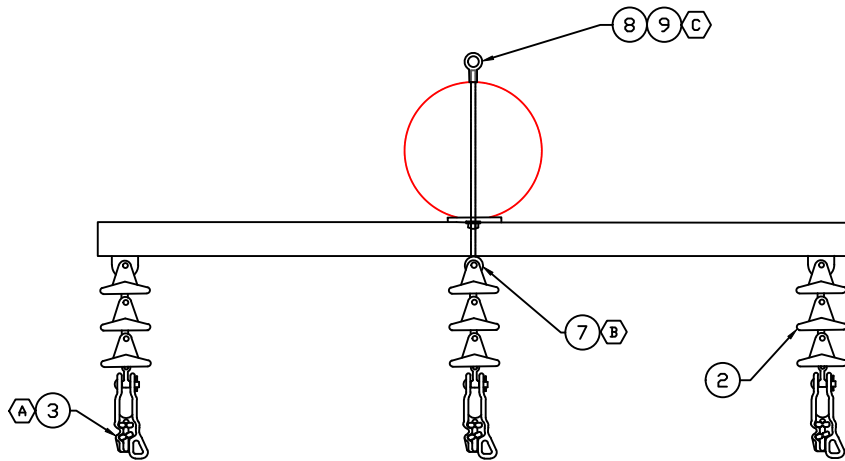

NOTES:

- (A) SELECT DEADEND SHOE APPROPRIATE FOR WIRE SIZE.
- (B) EYEBOLT TO BE INSTALLED IN TOP HOLE OF CROSSARM BRACKET, AS SHOWN.
- (C) GUY ASSEMBLY NOT SHOWN. SEE DWG TG-21 FOR REFERENCE.

DWG. REF.	XRM-10B QTY	LIST OF MATERIALS	GREENVILLE UTILITIES COMMISSION GREENVILLE, NORTH CAROLINA					
		DESCRIPTION	10' DEADEND DISTRIBUTION CROSSARM					
1	1	ARMS, 10' DE FIBERGLASS		DWN. DRB CKD. JLS SCALE: N.T.S.		DATE: 5/27/2022 APPD. JLS		DWG. NO. XRM-10DE
2	3	INSULATORS, POLY DE BELLS						
3	3	DEADEND SHOE						
4	1	BOLT, MACHINE 5/8" X LENGTH"	DATE	DATE	REVISION			
5	2	SPRING LOCK WASHER, 5/8"						
6	3	WASHER, SQ. 4 X 4 X 13/16"						
7	1	EYE BOLT, 5/8" X LENGTH"						
8	1	5/8" EYE NUT						
9	1	GUY ASSEMBLY						

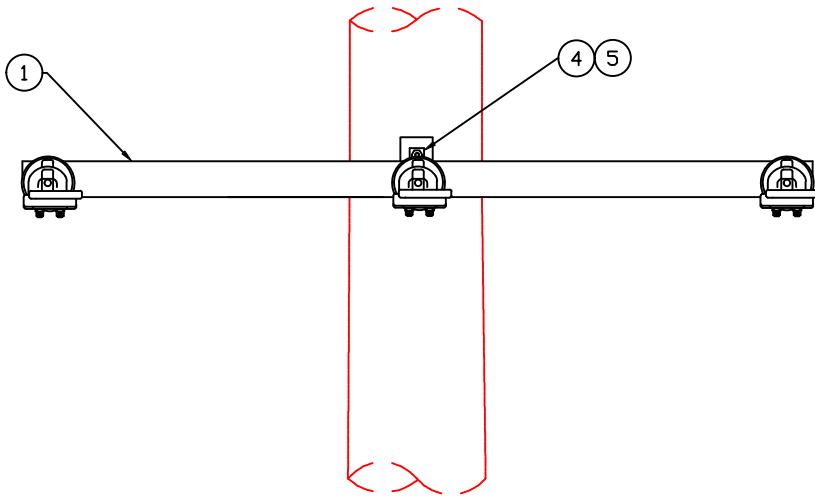

OVERHEAD VIEW

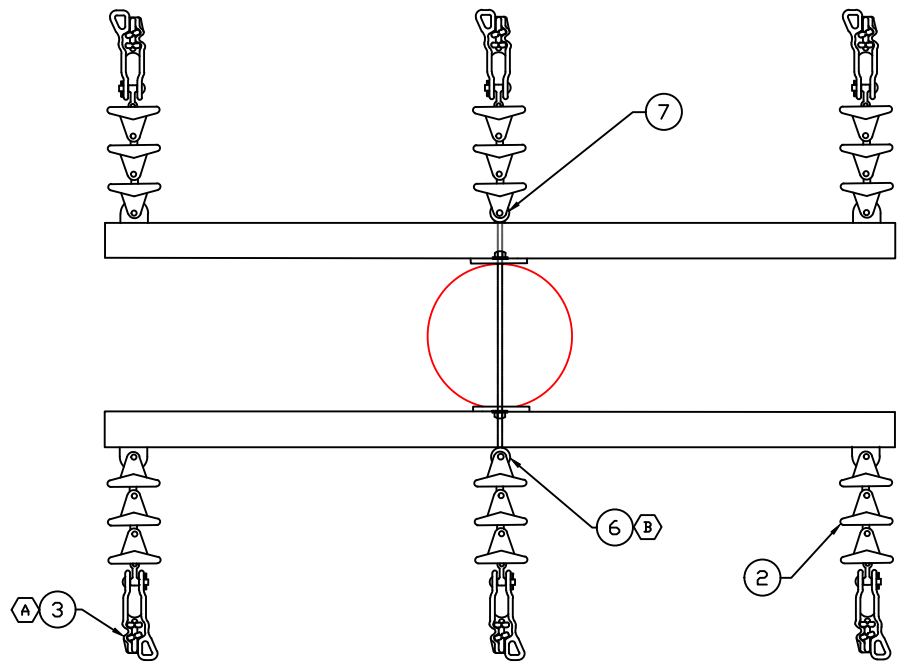

NOTES:

- (A) SELECT DEADEND SHOE APPROPRIATE FOR WIRE SIZE.
- (B) EYEBOLT TO BE INSTALLED IN TOP HOLE OF CROSSARM BRACKET, AS SHOWN.

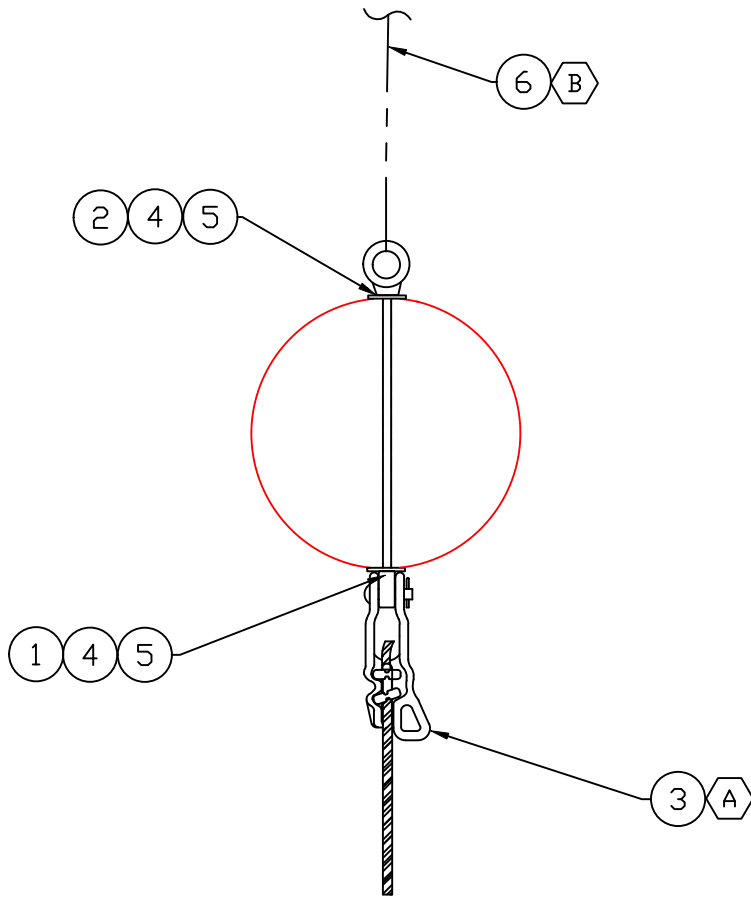

DWG. REF.	QTY	LIST OF MATERIALS	GREENVILLE UTILITIES COMMISSION GREENVILLE, NORTH CAROLINA			
		DESCRIPTION		10' DOUBLE DEADEND DISTRIBUTION CROSSARM		DWG. NO. XRM-10DDE
1	2	ARMS, 10' DE FIBERGLASS		DWN. DRB	DATE: 5/27/2022	
2	6	INSULATORS, POLY DE BELLS	CKD. JLS	APPD. JLS		
3	6	DEADEND SHOE	SCALE: N.T.S.	DATE	REVISION	
4	1	BOLT, MACHINE 5/8" X LENGTH"	DATE			
5	2	SPRING LOCK WASHER, 5/8"				
6	1	EYE BOLT, 5/8" X LENGTH"				
7	1	5/8" EYE NUT				

OVERHEAD VIEW



NOTES:

- (A) SELECT DEADEND SHOE APPROPRIATE FOR WIRE SIZE.
- (B) REFERENCE DWG TG-21 FOR SINGLE DOWN GUY ASSEMBLY.

DWG. REF.	QTY	LIST OF MATERIALS	GREENVILLE UTILITIES COMMISSION GREENVILLE, NORTH CAROLINA				
		DESCRIPTION		NEUTRAL DEADEND			
1	1	EYE BOLT, 5/8" X LENGTH"			DWN. DRB DATE: 06/03/2022 CKD. JLS APPD. JLS SCALE: N.T.S. DATE DATE REVISION		
2	1	5/8" EYE NUT					
3	1	DEADEND SHOE					
4	2	WASHER, SQUARE, 4" X 4" X 13/16" HOLE					
5	2	SPRING LOCK WASHER, 5/8"					
6	1	SINGLE DOWN GUY					

OVERHEAD VIEW

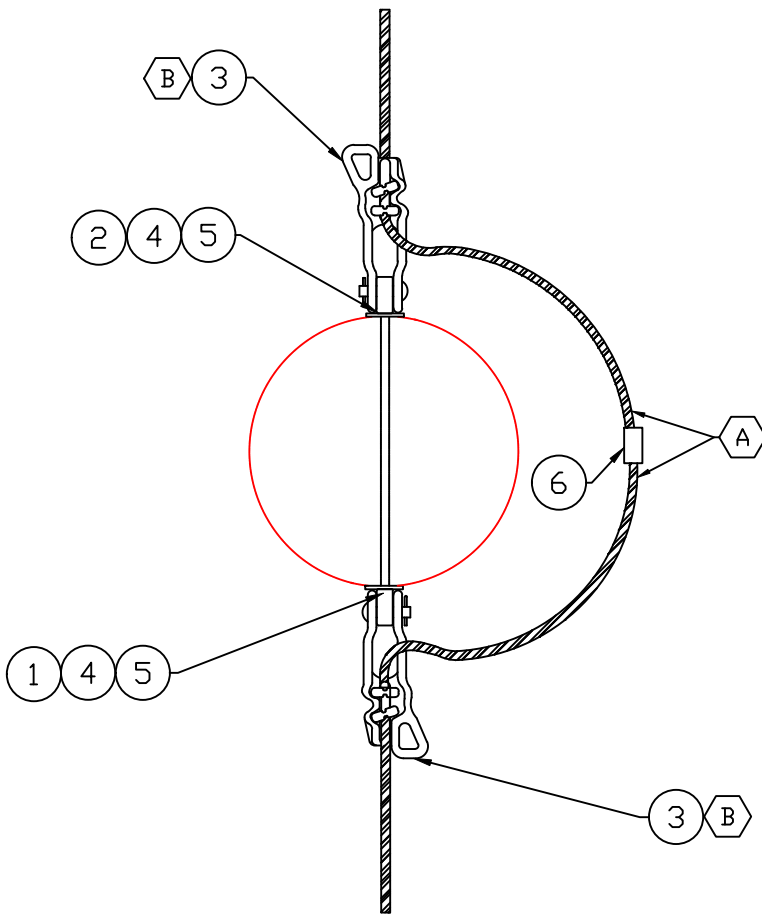

NOTES:

- Ⓐ MEASURE AND TRIM EXCESS NEUTRAL CONDUCTORS AS REQUIRED AND CONNECT ENDS WITH SQUEEZON/AMPACT, ITEM (6).
- Ⓑ SELECT DEADEND SHOE & SQUEEZON/AMPACT APPROPRIATE FOR WIRE SIZE.

DWG. REF.	QTY	LIST OF MATERIALS	GREENVILLE UTILITIES COMMISSION GREENVILLE, NORTH CAROLINA			
		DESCRIPTION		NEUTRAL DOUBLE DEADEND		
1	1	EYE BOLT, 5/8" X LENGTH"		DWN. DRB CKD. JLS SCALE: N.T.S. DATE	DATE: 06/03/2022	
2	1	5/8" EYE NUT	APPD. JLS			
3	2	DEADEND SHOE	DATE		REVISION	
4	2	WASHER, SQUARE, 4" X 4" X 13/16" HOLE				
5	2	SPRING LOCK WASHER, 5/8"				
6	1	SQUEEZON/AMPACT (REQUIRED SIZE)				

NOTES:

1. THE TABLE BELOW SHALL BE COMPLETED FOR EACH PROJECT.
2. SUITABLE SUSPENSION CLAMPS MUST BE SELECTED FOR THE CONDUCTOR BEING USED. THE FOLLOWING ARE TO BE CONSIDERED: TYPE OF CONDUCTOR, DIAMETER OF CONDUCTOR (CONSIDERING ARMOR RODS AND/OR LINERS), ETC.
3. THE CAPACITY OF THE HARDWARE MUST BE EQUAL TO OR GREATER THAN THE SPECIFIED MECHANICAL LOAD OF THE INSULATOR UNITS SHOWN IN THE TABLE BELOW.

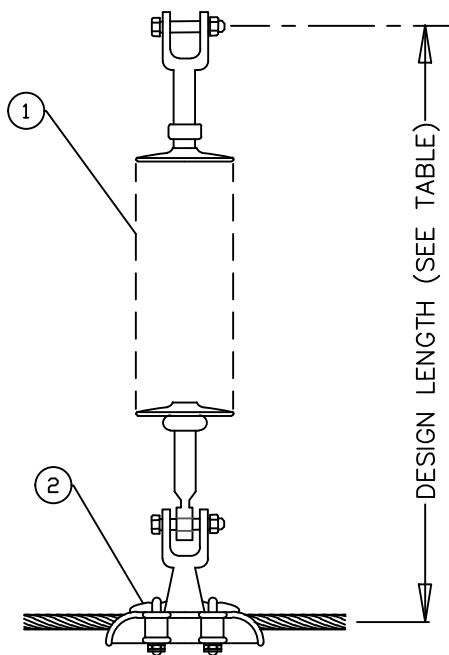

TANGENT ASSEMBLY
DM-1AM (OR) DM-1BM

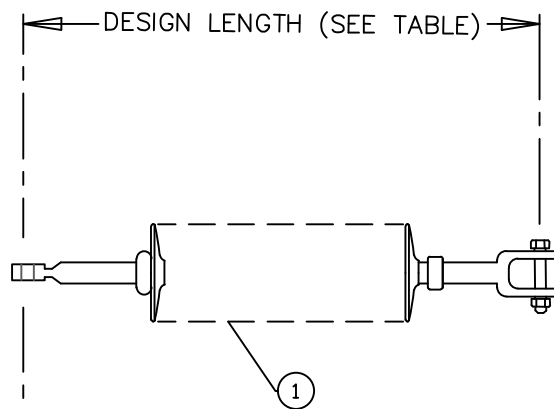

DEADEND ASSEMBLY
DM-1EM

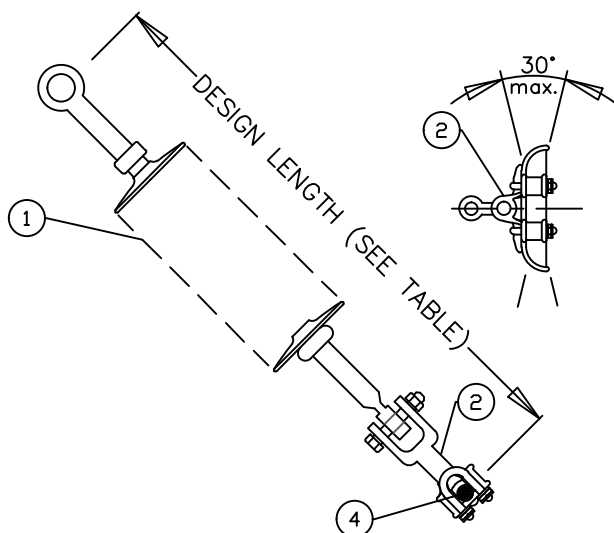

ANGLE ASSEMBLY
DM-1CM

15 KV STOCK NUMBER: 206920	ASSEMBLY		
	TANGENT	ANGLE	DEADEND
QUANTITY OF UNITS	1	1	1
INSULATION LEVEL (kV)	18	18	18
LEAKAGE DISTANCE (in.)	16	16	16
SPEC. MECH. LOAD (lb.)	10,000	10,000	10,000
INSULATOR WEIGHT (lb.)	2.3	2.3	2.3
DESIGN LENGTH (in.)	12.5	12.5	12.5
COLOR OF UNITS	GRAY	GRAY	GRAY

DWG. REF.	LIST OF MATERIALS	
	ITEM	DESCRIPTION
1		INSULATOR, SUSPENSION. POLYMER
2		CLAMP, SUSPENSION x REQ. CONDUCTOR SIZE
3		DEADEND SHOE, x REQ. CONDUCTOR SIZE
4	*	ARMOR ROD x REQ. CONDUCTOR SIZE
	*	Armor Rod not required if suspension clamp is cushioned

GREENVILLE UTILITIES COMMISSION
GREENVILLE, NORTH CAROLINA

SUSPENSION INSULATOR ASSEMBLY

DWN. DRB	DATE: 06/01/2022	DWG. NO. DM-1
CKD. JLS	APPD. JLS	
SCALE: N.T.S.		
DATE	DATE REVISION	

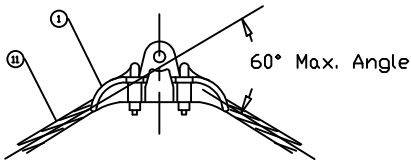

TANGENT & ANGLE CLAMP
TM-4A

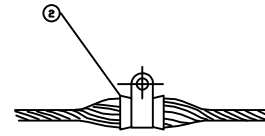

TANGENT ASSEMBLY
TM-4B

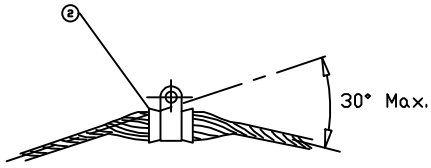

TYPE 1

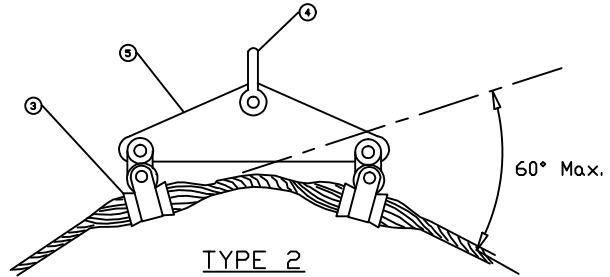

TYPE 2

ANGLE ASSEMBLY
TM-4C (NOTE 1)

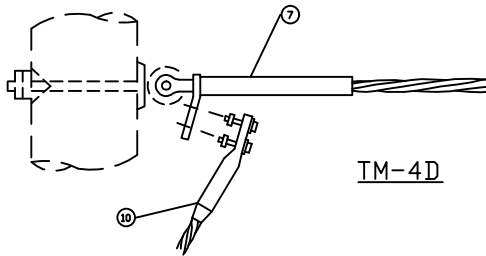

TM-4D

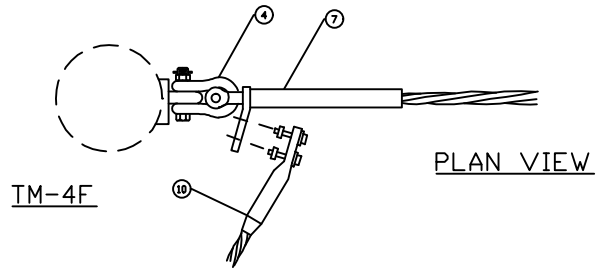

TM-4F

PLAN VIEW

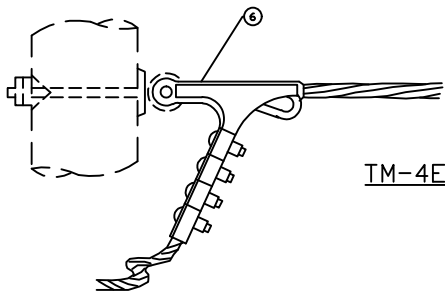

TM-4E

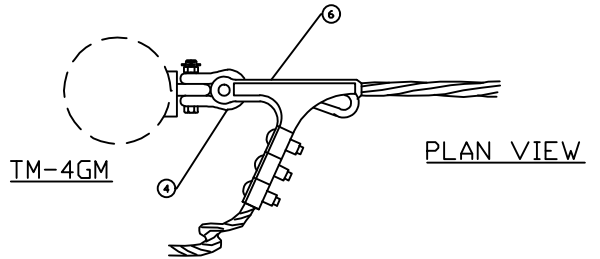

TM-4GM

PLAN VIEW

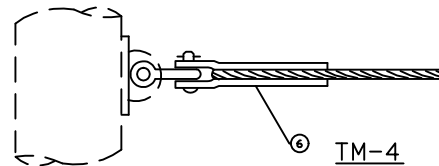

TM-4

DEADEND ASSEMBLY

NOTES:

1. The appropriate cushioned suspension angle assembly shall be installed for the line angles shown on the plan-profile drawings:

- A. For angles from 0 degrees to 30 degrees, use type 1
- B. For angles from 30 degrees to 60 degrees use type 2

DWG. REF.	LIST OF MATERIALS		GREENVILLE UTILITIES COMMISSION GREENVILLE, NORTH CAROLINA			
	ITEM	DESCRIPTION	O.H.G.W. ASSEMBLIES CUSHIONED SUSPENSION AND SUSPENSION CLAMPS			
1		CLAMP, SUSPENSION (TO 60°)	 DWN. JLS CKD. KW SCALE: N.T.S. DATE	DATE: 02/27/19		DWG. NO. TM-4
2		CLAMP, CUSHIONED SUSPENSION		APPD. KW		
3		CLAMP, CUSHIONED SUSP. & CLEVIS EYE		DATE	REVISION	
4		ANCHOR SHACKLE 40,000 LBS. BNC				
5		YOLK PLATE				
6		CLAMP BOLTED DEADEND (3 BOLT)				
7		CLAMP, COMPRESSION DEADEND				
8		LINK, EXTENSION, CLEVIS 6"				
9		JUMPER CONNECTOR, COMPRESSION				
10		JUMPER TERMINAL, COMPRESSION				
11		ARMOR ROD				

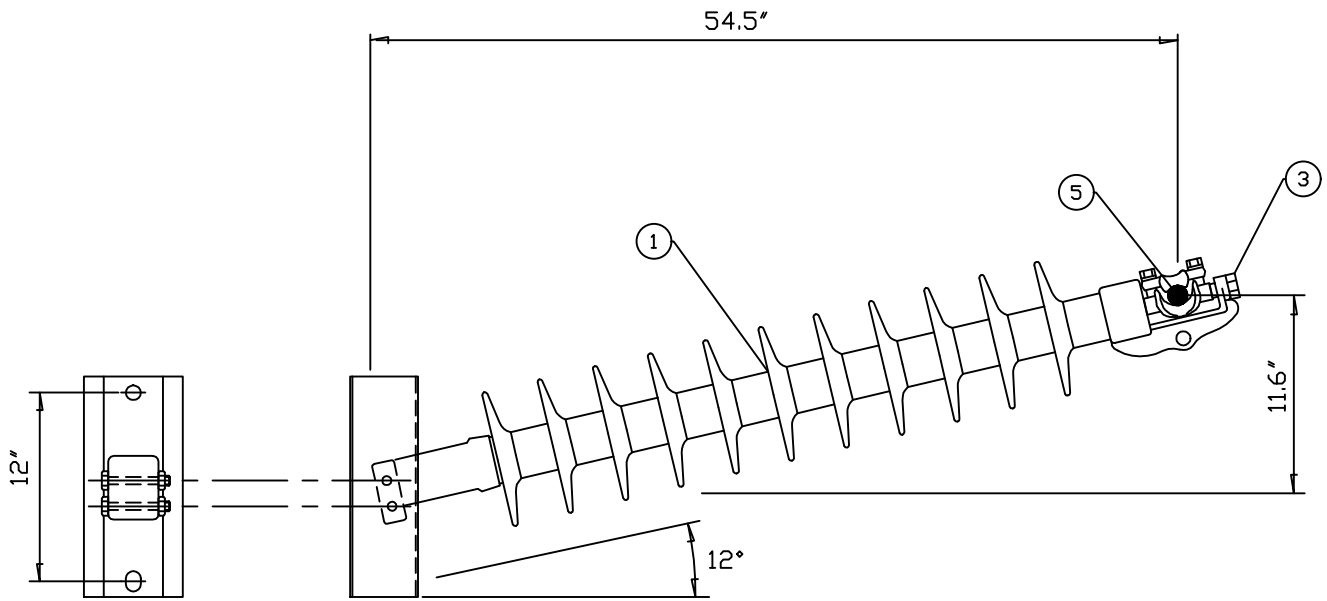

TM-3BM - HORIZONTAL POST INSULATOR

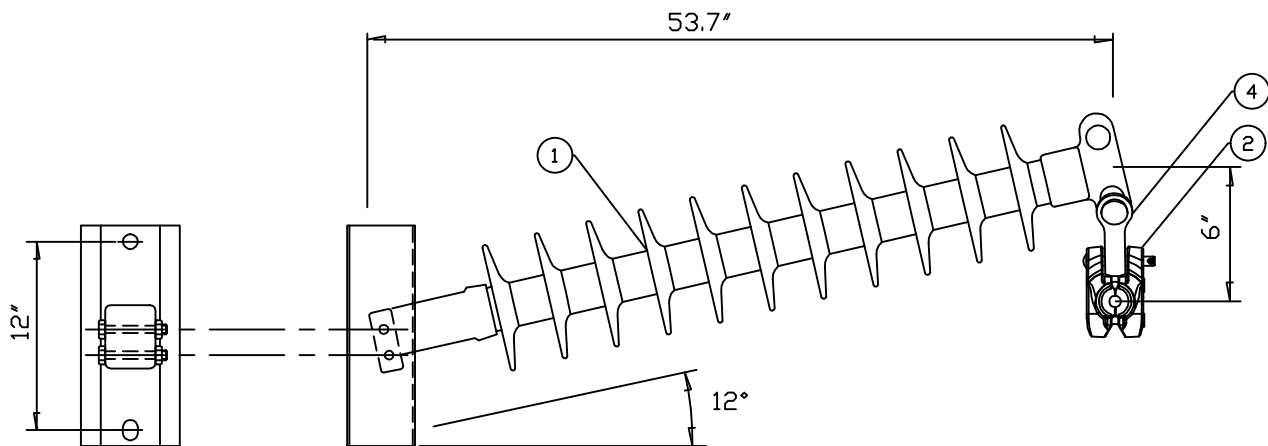

TM-3DM - HORIZONTAL POST INSULATOR - TANGENT & SMALL ANGLE

DWG. REF.	TM-3		LIST OF MATERIALS	GREENVILLE UTILITIES COMMISSION GREENVILLE, NORTH CAROLINA	
	BM	DM	DESCRIPTION	HORIZONTAL POST INSULATOR ASSEMBLY	
1	1	1	INSULATOR, POLYMER HORIZONTAL POST		DATE: 03/01/19 APPD. KW
2	-	1	CLAMP, SUSPENSION x REQ. CONDUCTOR SIZE		
3	1	-	CLAMP, TRUNION x REQ. CONDUCTOR SIZE		
4	-	1	Y-CLEVIS, BALL		
5	1	*	ARMOR ROD x REQ. CONDUCTOR SIZE		
				SCALE: N.T.S.	DATE
					DATE
					REVISION
		*	Armor Rod not required if suspension clamp is cushioned		

DWG. NO.
TM-3

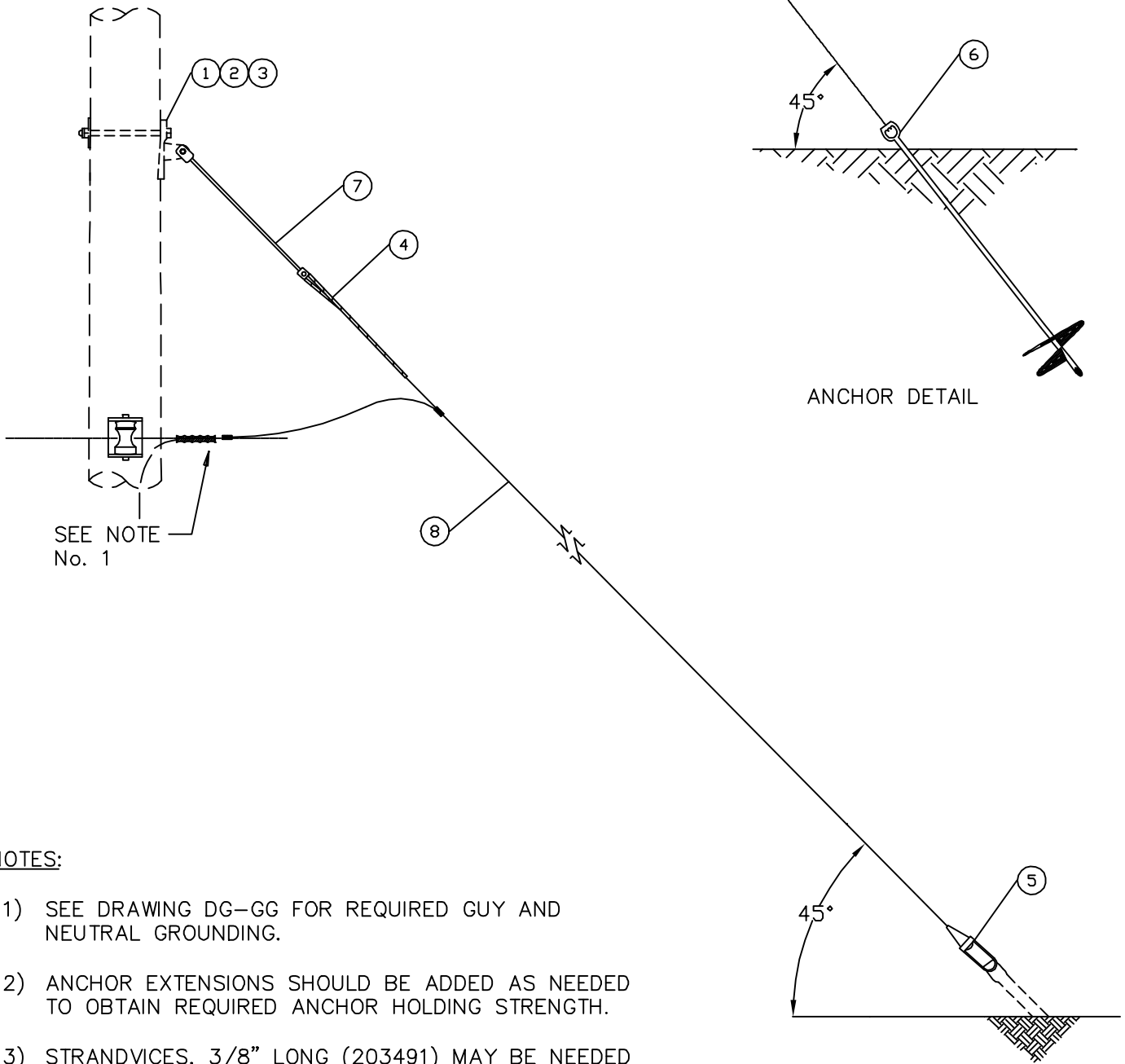

NOTES:

- 1) SEE DRAWING DG-GG FOR REQUIRED GUY AND NEUTRAL GROUNDING.
- 2) ANCHOR EXTENSIONS SHOULD BE ADDED AS NEEDED TO OBTAIN REQUIRED ANCHOR HOLDING STRENGTH.
- 3) STRANDVICES, 3/8" LONG (203491) MAY BE NEEDED WHEN ATTACHING 2 GUY TO A SINGLE ANCHOR.

DWG. REF.	QTY		LIST OF MATERIALS	STOCK #	GREENVILLE UTILITIES COMMISSION GREENVILLE, NORTH CAROLINA			
	12	14			DESCRIPTION	DISTRIBUTION SINGLE DOWN GUY		
1	1	1	PLATES, P-345 GUY	203410		DATE: 07/31/19		DWG. NO.
2	1	-	BOLTS, 3/4" X 12" MACHINE	202230		APPD. KW		
2	-	1	BOLTS, 3/4" X 14" MACHINE	202240		SCALE: N.T.S.		
3	1	1	WASHERS, 3 X 3 CURVED	204450		DATE	REVISION	
4	1	1	GRIPS, 3/8" PREFORM GUY GDE-2107	207540				
5	1	1	STRANDVICES, 3/8"	203490			DG-12	
6	1	1	ANCHOR, 10" SCREW	203980			DG-14	
7	*	*	ISOLATORS, STRAIN X REQUIRED LENGTH	-				
8	*	*	WIRE, 3/8" GUY	204470				
	1	1	GUARD, YELLOW GUY	208690				
* QUANTITY DEPENDS ON POLE HEIGHT & CONDUCTOR CLEARANCE								

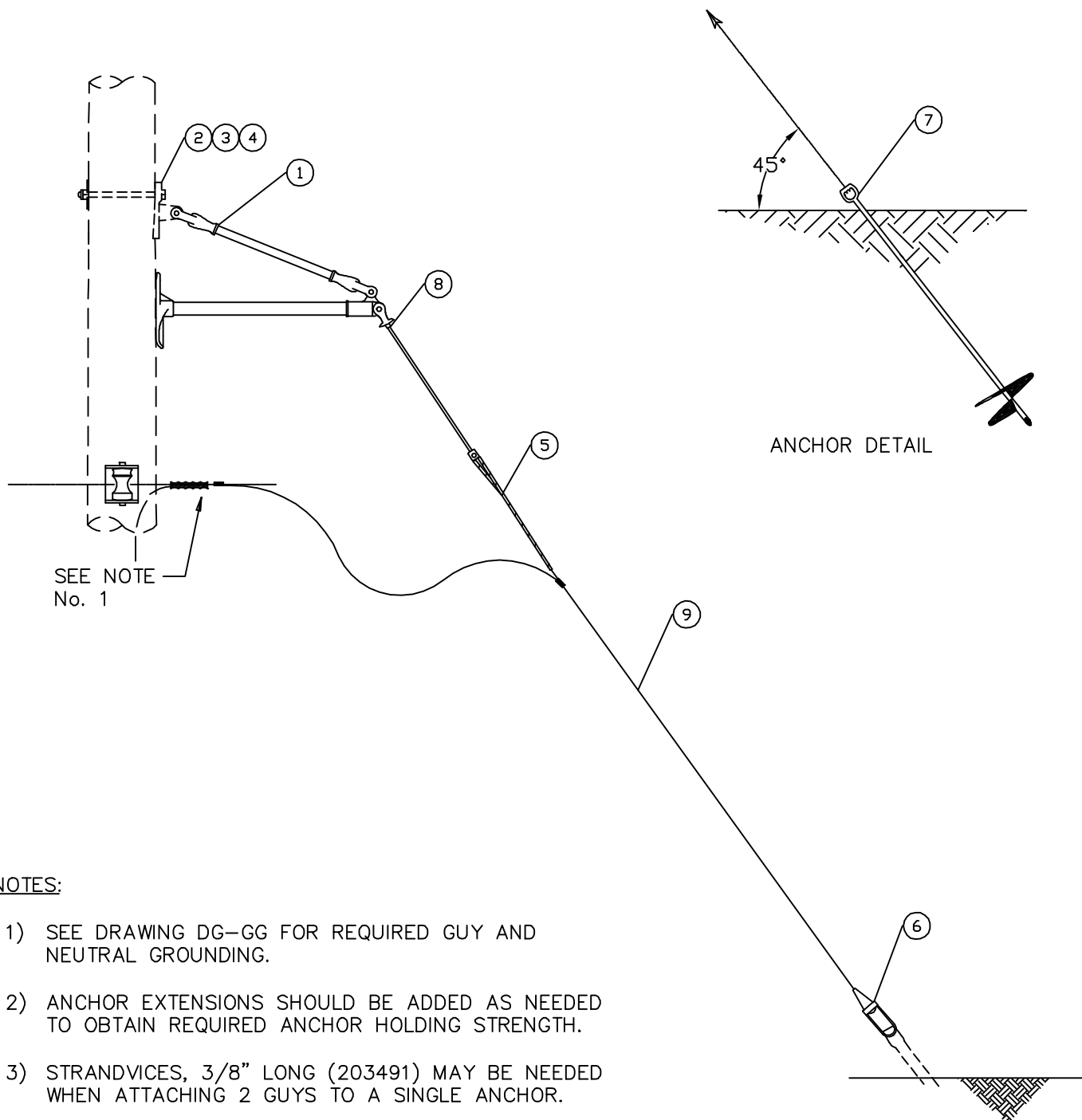

NOTES:

- 1) SEE DRAWING DG-GG FOR REQUIRED GUY AND NEUTRAL GROUNDING.
- 2) ANCHOR EXTENSIONS SHOULD BE ADDED AS NEEDED TO OBTAIN REQUIRED ANCHOR HOLDING STRENGTH.
- 3) STRANDVICES, 3/8" LONG (203491) MAY BE NEEDED WHEN ATTACHING 2 GUYS TO A SINGLE ANCHOR.

DWG. REF.	QTY		LIST OF MATERIALS	STOCK #
	12	14		
1	1	1	GUY, FIBERGLASS SIDEWALK	207420
2	1	1	PLATES, P-345 GUY	203410
3	1	-	BOLTS, 3/4" X 12" MACHINE	202230
3	-	1	BOLTS, 3/4" X 14" MACHINE	202240
4	1	1	WASHERS, 3 X 3 CURVED	204450
5	1	1	GRIPS, 3/8" PREFORM GUY GDE-2107	207540
6	1	1	STRANDVICES, 3/8"	203490
7	1	1	ANCHOR, 10" SCREW	203980
8	*	*	ISOLATORS, STRAIN X REQUIRED LENGTH	-
9	*	*	WIRE, 3/8" GUY	204470
	1	1	GUARD, YELLOW GUY	208690
* QUANTITY DEPENDS ON POLE HEIGHT & CONDUCTOR CLEARANCE				



GREENVILLE UTILITIES COMMISSION
GREENVILLE, NORTH CAROLINA

DISTRIBUTION SIDEWALK GUY

DWN. JLS	DATE: 08/28/19
CKD. KW	APPD. KW
SCALE: N.T.S.	
DATE	DATE
	REVISION

DWG. NO.
SWG-12
SWG-14

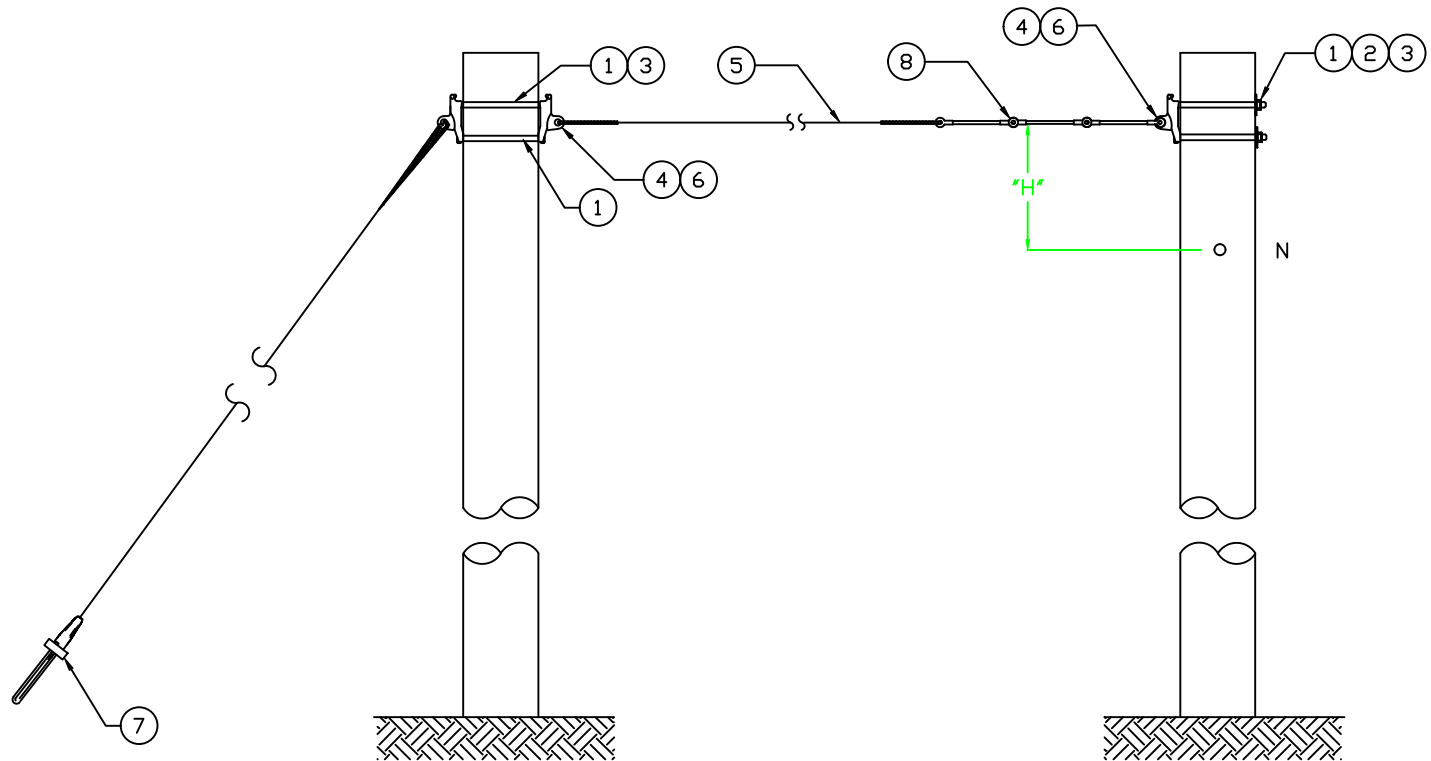

NOTES:

1. ALL GUYS MUST CONTAIN GUY STRAIN INSULATORS. THE COMBINED LENGTH OF STRAIN INSULATORS MUST BE GREATER THAN "H" (VERTICAL DISTANCE BETWEEN GUY WIRE AND NEUTRAL CONDUCTOR)
2. GROUNDS ARE TO STOP AT THE NEUTRAL POSITION EXCEPT TO RISE TO A LIGHTNING ARRESTER OR TRANSFORMER.
3. GUY ATTACHMENT POINT SHALL BE 9" BELOW CONDUCTOR ATTACHMENT POINT.

DWG. REF.	QTY	LIST OF MATERIALS	GREENVILLE UTILITIES COMMISSION GREENVILLE, NORTH CAROLINA			
		DESCRIPTION		SPAN GUY – WITH PREFORMED GRIPS.		
1	4	BOLT, MACHINE 5/8" X REQUIRED LENGTH		DWN. DRB	DATE: 12/21/2022	
2	2	WASHER, SQUARE 2 1/4"	CKD. JLS	APPD. JLS		
3	4	WASHER, LOCK 5/8"	SCALE: N.T.S.			
4	3	PLATES, P-345 GUY	DATE	DATE	REVISION	
5	*	WIRE, 3/8" GUY		10/31/23	1	
6	3	GRIPS, 3/8" PREFORM GUY				
7	1	STRANDVICES, 3/8"				
8	*	GUY, STRAIN INSULATOR				
* QUANTITY VARIES. USE AS REQUIRED						

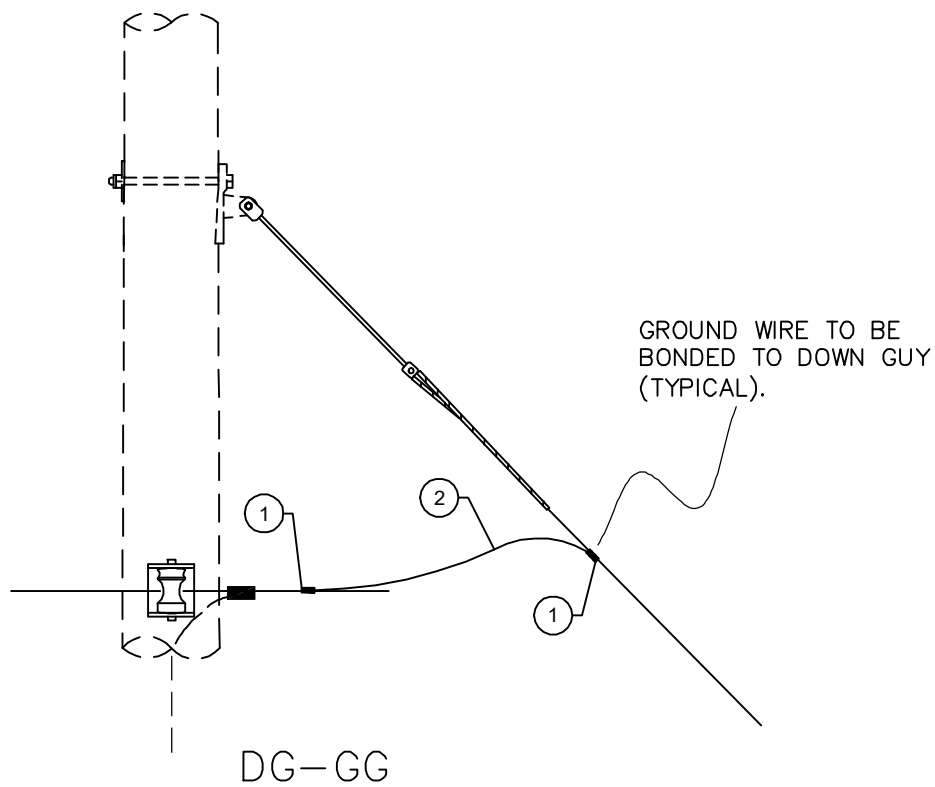

NOTES:

- 1) NEUTRAL SHALL BE GROUNDED AT EVERY TRANSFORMER LOCATION AND ADDITIONAL POINTS TO TOTAL NOT LESS THAN 4 GROUNDS PER MILE. (TYPICALLY 1 GROUND EVERY 4 POLES)
- 2) WHEN MULTIPLE GUYS ARE PRESENT, GUYS WILL BE TIED TOGETHER USING THE LAST GUY TO GROUND TO THE NEUTRAL. ADD WIRE AND SQUEEZONS AS NEEDED.
- 3) SEE DRAWING DM-9 FOR DRIVEN GROUND ROD GROUNDING ASSEMBLY.

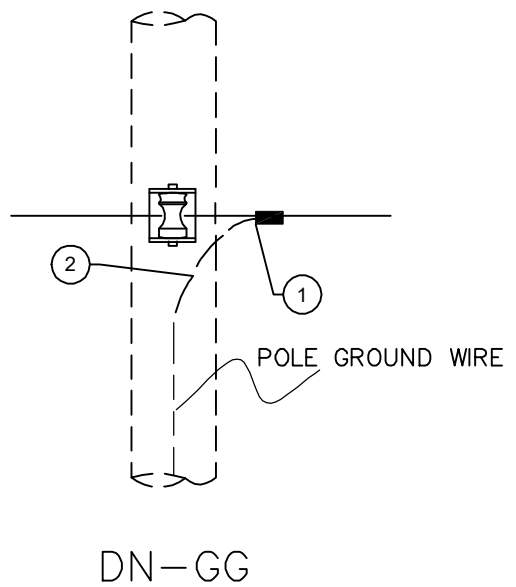

DWG. REF.	QTY		LIST OF MATERIALS		GREENVILLE UTILITIES COMMISSION GREENVILLE, NORTH CAROLINA			
	DG	DN	DESCRIPTION	STOCK #	DISTRIBUTION GUY AND NEUTRAL GROUNDING GUIDE			
1	2	1	SQUEEZONS, #2	203050				
2	*	*	WIRE, #4 SOFT DRAWN COPPER (ft)	204490				
					DWG. NO. DG-GG DN-GG			
* As Required								

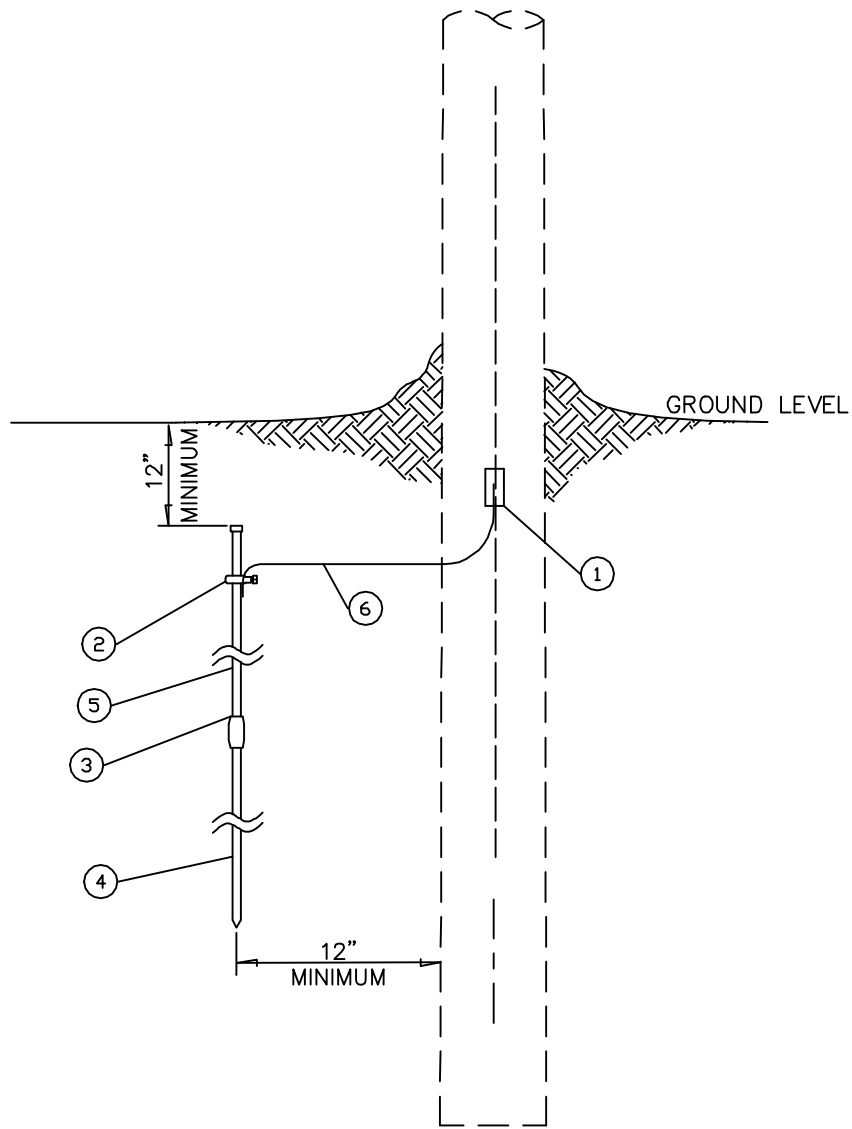

NOTES:

- 1) MAXIMUM GROUND RESISTANCE READING SHALL BE 25 OHMS. IF THE CLAMP-ON RESISTANCE MEASUREMENT IS USED, THE GROUND ROD SHALL BE INSTALLED AND TEMPORARILY BONDED UNTIL THE GROUND RESISTANCE READING IS TAKEN.
- 2) ADDITIONAL ROD SECTIONS SHALL BE ADDED AS NECESSARY TO REDUCE RESISTANCE TO 25 OHMS MAXIMUM. HORIZONTAL SPACING BETWEEN ADDITIONAL RODS SHALL BE NO LESS THAN 6 FEET.
- 3) GROUND ROD SHALL BE INSTALLED IN UNDISTURBED SOIL.

DWG. REF.	QTY	LIST OF MATERIALS		GREENVILLE UTILITIES COMMISSION GREENVILLE, NORTH CAROLINA			
		DESCRIPTION	STOCK #	 DRIVEN GROUND ROD GROUNDING ASSEMBLY - WOOD POLE			
1	*	SQUEEZONS, YC4C4 COPPER	206240				
2	1	GROUND - ROD CLAMP, 5/8"	NS	APPD. KW			
3	1	GROUND - ROD COUPLING, 5/8"	NS				
4	1	GROUND - ROD, 5/8" x 12'-0"	207440				
5	1	GROUND - ROD, 5/8" x 8'-0"	203850				
6	*	GROUND - WIRE, #4 (ft.)	204490				
		* - As Required					

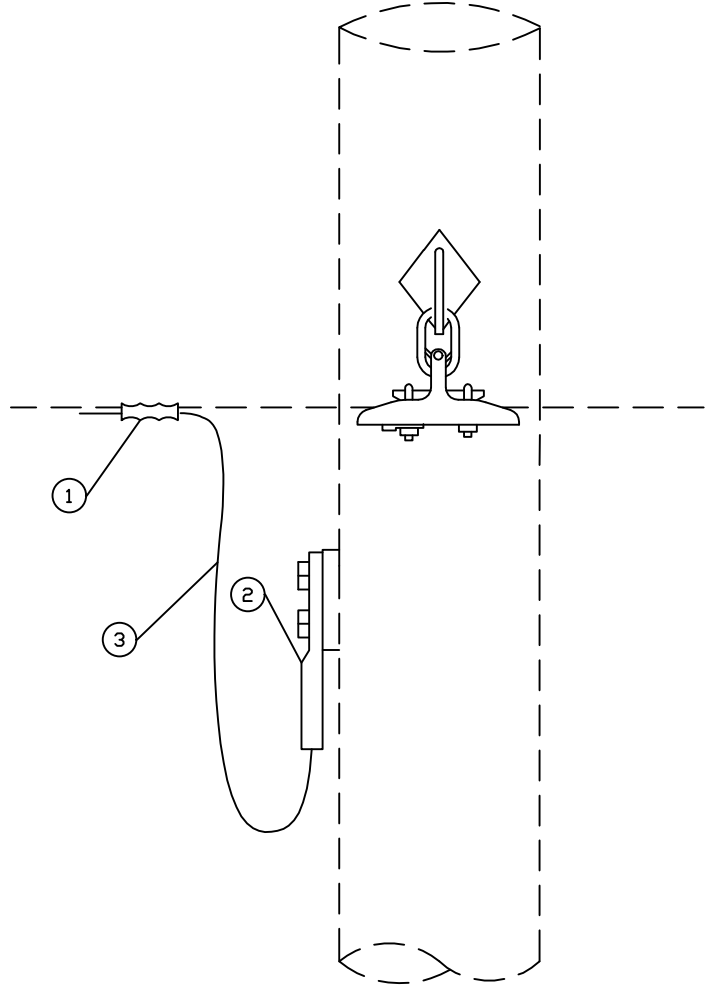
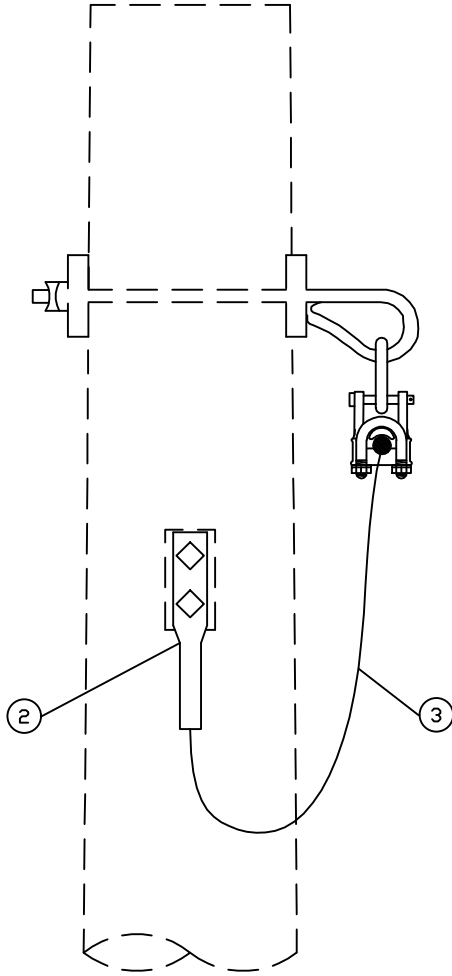

DWG. REF.	LIST OF MATERIALS	
	ea.	DESCRIPTION
1	1	CONNECTOR - COMPRESSION, BI-METALLIC, 7 No. 9 ALUMOWELD TO #4
2	1	CONNECTOR - COMPRESSION, NEMA 2-HOLE FOR #4
3	5	GROUND - WIRE, #4 (ft.)

GREENVILLE UTILITIES COMMISSION
GREENVILLE, NORTH CAROLINA

OVERHEAD GROUND WIRE GROUNDING
ASSEMBLY - STEEL POLE

DWN. JLS		DATE: 03/13/19		DWG. NO. TM-9X(S)
CKD. KW		APPD. KW		
SCALE: N.T.S.				
DATE		DATE	REVISION	

NG-1/0 SUB-ASSY

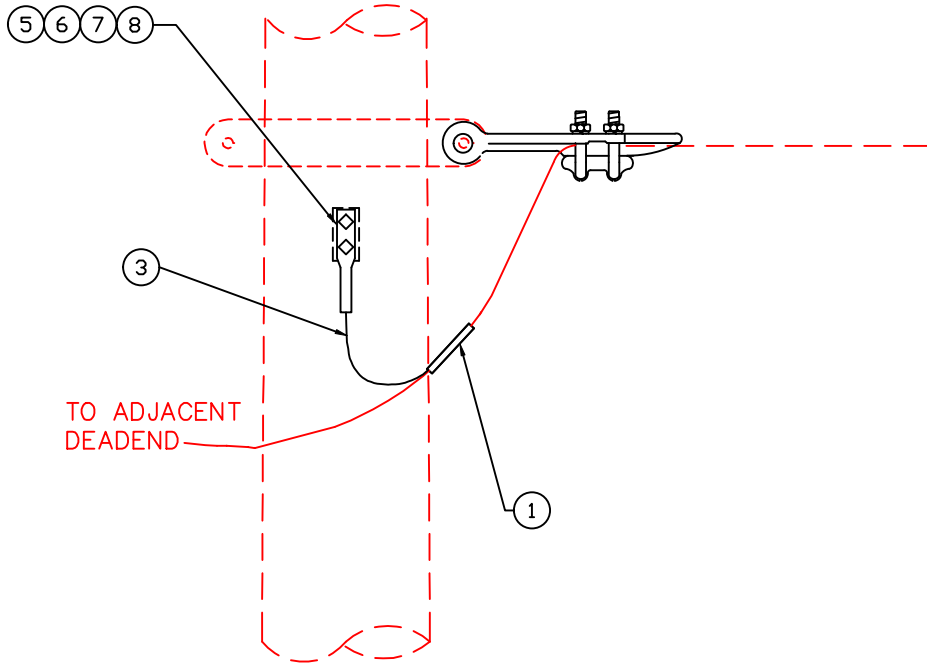

NG-336 SUB-ASSY

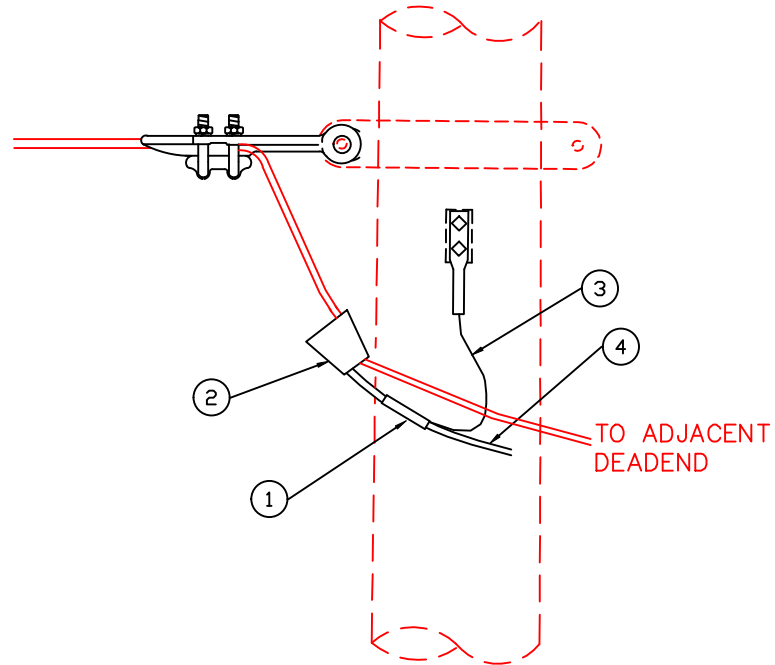

DWG. REF.	NG-1/0 QTY	NG-336 QTY	LIST OF MATERIALS	GREENVILLE UTILITIES COMMISSION GREENVILLE, NORTH CAROLINA			
			DESCRIPTION		NEUTRAL GROUNDING ASSEMBLY		
1	1	1	SQUEEZEON CONNECTOR #2		DWN. DRB CKD. JLS SCALE: N.T.S. DATE	DATE: 06/01/2022	
2		1	AMPACT CONNECTOR 336-1/0	APPD. JLS			
3	*	*	WIRE, #4 SOFT DRAWN				
4		*	WIRE 1/0 ACSR				
5	1	1	#4 COPPER 2-HOLE NEMA PAD	DATE	DATE	REVISION	
6	2	2	BOLT MACHINE, 1/2" X 1"				
7	2	2	FLAT WASHER, 1/2"				
8	2	2	LOCK WASHER, 1/2"				
			*LENGTH OF WIRE AS REQUIRED				

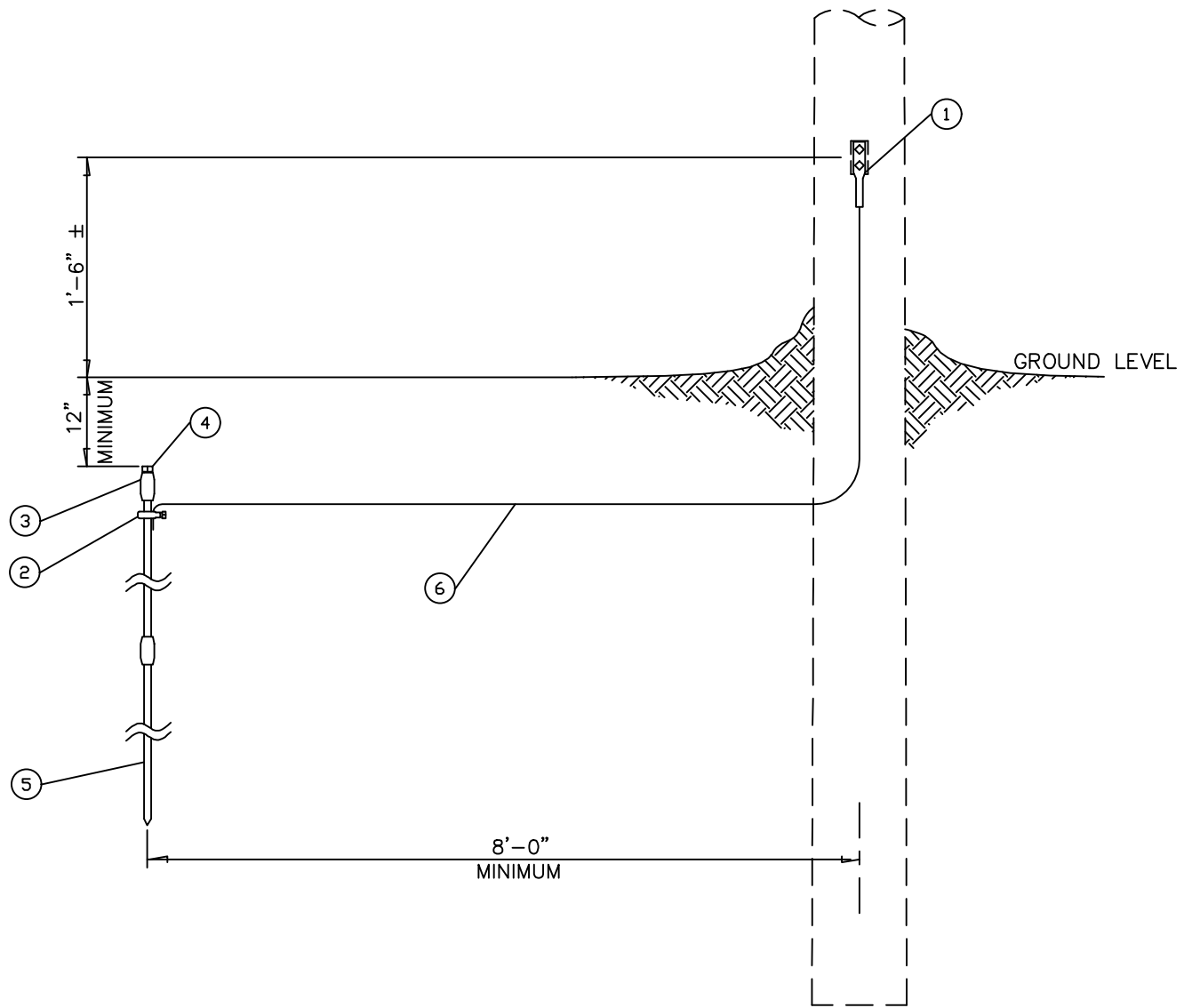

NOTES:

- 1) MAXIMUM GROUND RESISTANCE READING SHALL BE 25 OHMS. IF THE CLAMP-ON RESISTANCE MEASUREMENT IS USED, THE GROUND ROD SHALL BE INSTALLED AND TEMPORARILY BONDED UNTIL THE GROUND RESISTANCE READING IS TAKEN. ADDITIONAL ROD SECTIONS SHALL BE ADDED AS NECESSARY TO REDUCE RESISTANCE TO 25 OHMS MAXIMUM.
- 2) SPECIFY TM-9R FOR ADDITIONAL GROUND ROD SECTION AND COUPLING.
- 3) GROUND ROD TO BE INSTALLED IN UNDISTURBED SOIL.

DWG. REF.	TM-9		LIST OF MATERIALS DESCRIPTION	GREENVILLE UTILITIES COMMISSION GREENVILLE, NORTH CAROLINA			
	SP	R			DRIVEN GROUND ROD GROUNDING ASSEMBLY - STEEL POLE		
1	1	-	CONNECTOR - COMPRESSION, NEMA 2 HOLE #4		DWN. JLS CKD. KW SCALE: N.T.S.	DATE: 03/13/19	
2	1	-	GROUND - ROD CLAMP, GALVANIZED, 5/8"	APPD. KW			
3	1	1	GROUND - ROD COUPLING, GALVANIZED, 5/8" THREADED				
4	1	-	GROUND - DRIVING STUD, STEEL, 5/8"				
5	1	1	GROUND - ROD, GALVANIZED, 5/8" x 10'-0"				
6	15	-	GROUND - WIRE, #4 (ft.)				
				DATE	DATE	REVISION	

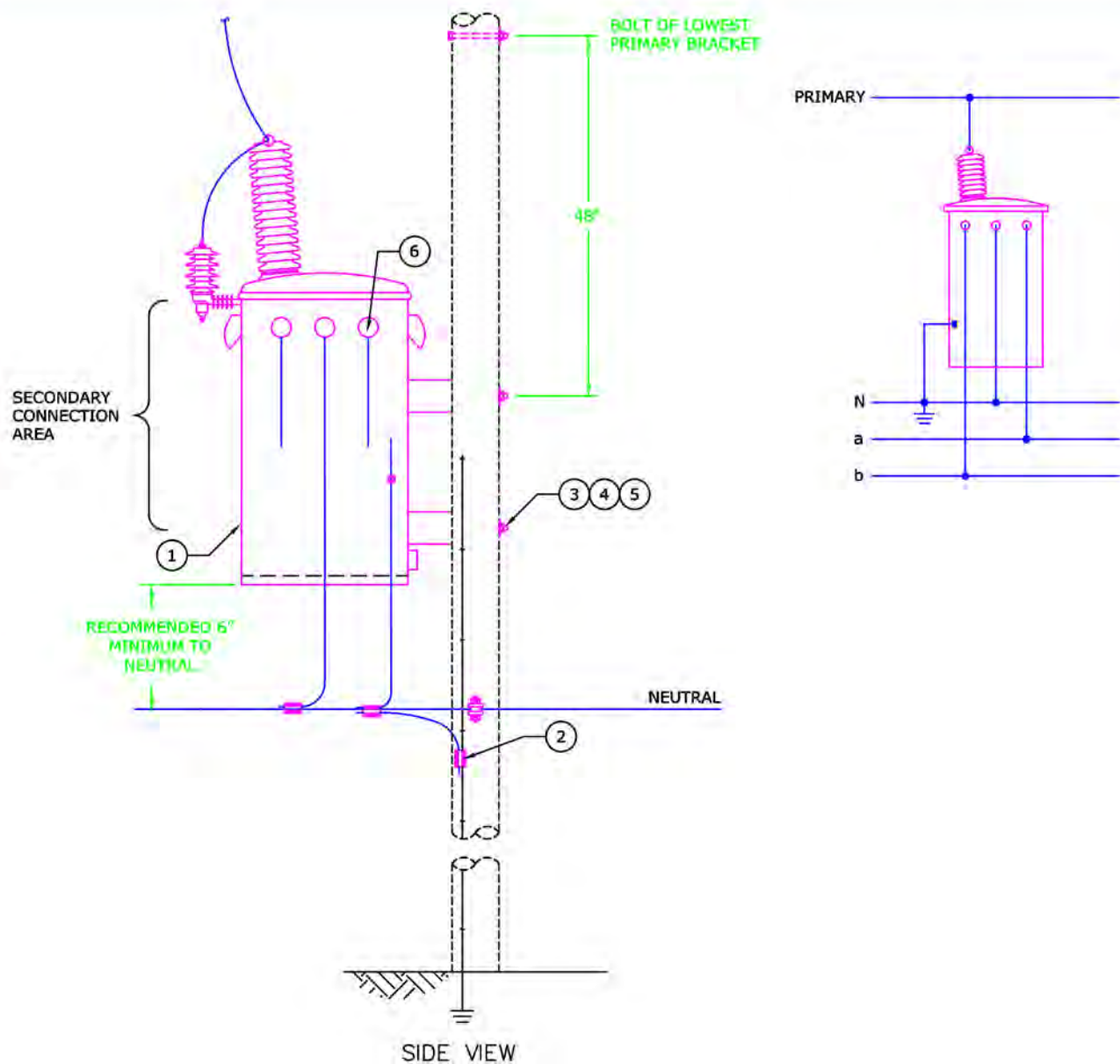

NOTES:

1. BOND TRANSFORMER NEUTRAL AND TRANSFORMER GROUND TO SYSTEM NEUTRAL AND SYSTEM GROUND.
2. CSP TRANSFORMERS MAY BE MOUNTED AT 45° TO THE LINE.
3. PLACE BIRD GUARDS AND USE INSULATED CONDUCTOR ON ALL PRIMARY LEADS.
4. GROUNDS ARE TO STOP AT THE NEUTRAL POSITION EXCEPT TO RISE TO A LIGHTNING ARRESTER OR TRANSFORMER WHEN APPLICABLE.
5. SEE DRAWING MG-11EC FOR CONDUCTOR SIZE.
6. CURRENT LIMITING FUSES AS REQUIRED. SEE DWG. M5-9CLEC.
7. NO DISCONNECT NEEDED ON A SINGLE PHASE TRANSFORMER.
8. TRANSFORMER SHALL BE INSTALLED SO THAT SECONDARY BUSHINGS ARE ON ROAD SIDE.
9. X2 GROUND WIRE SHALL BE #2 BARE COPPER & TANK GROUNDS SHALL BE #6 BARE COPPER.

DWG REF	QTY	LIST OF MATERIALS		GREENVILLE UTILITIES COMMISSION GREENVILLE, NORTH CAROLINA					
		DESCRIPTION	STOCK #	SINGLE-PHASE CSP TRANSFORMER 240/120 VOLT					
1	1	TRANSFORMER, REQUIRED SIZE	-		DWN.	JLS	DATE:	11/29/21	DWG. NO.
2	-	CONNECTOR	-		CKD.	KW	APPD.		
3	2	BOLT, MACHINE	-		SCALE:	NONE			
4	2	WASHER, SQUARE FLAT, 2 1/4"	-		DATE	REVISION	DATE	REVISION	
5	2	WASHER, SQUARE, FLAT	-						G105EC
6	-	UB-4 OR UB-6 AS NEEDED	-						
7	1	CLAMP (NOT SHOWN)	-						
8	1	STIRRUP, SIZE AS REQ. (NOT SHOWN)	-						

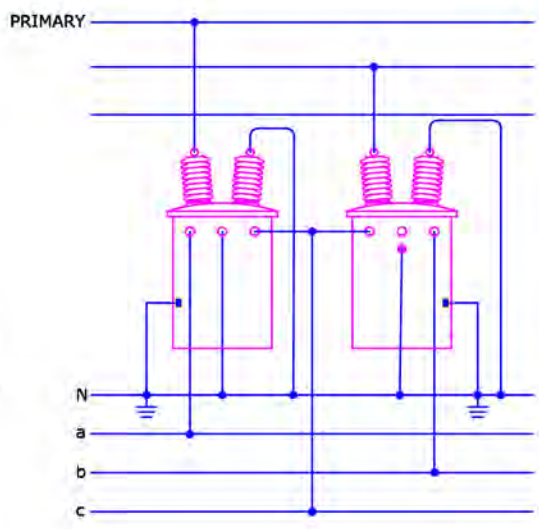
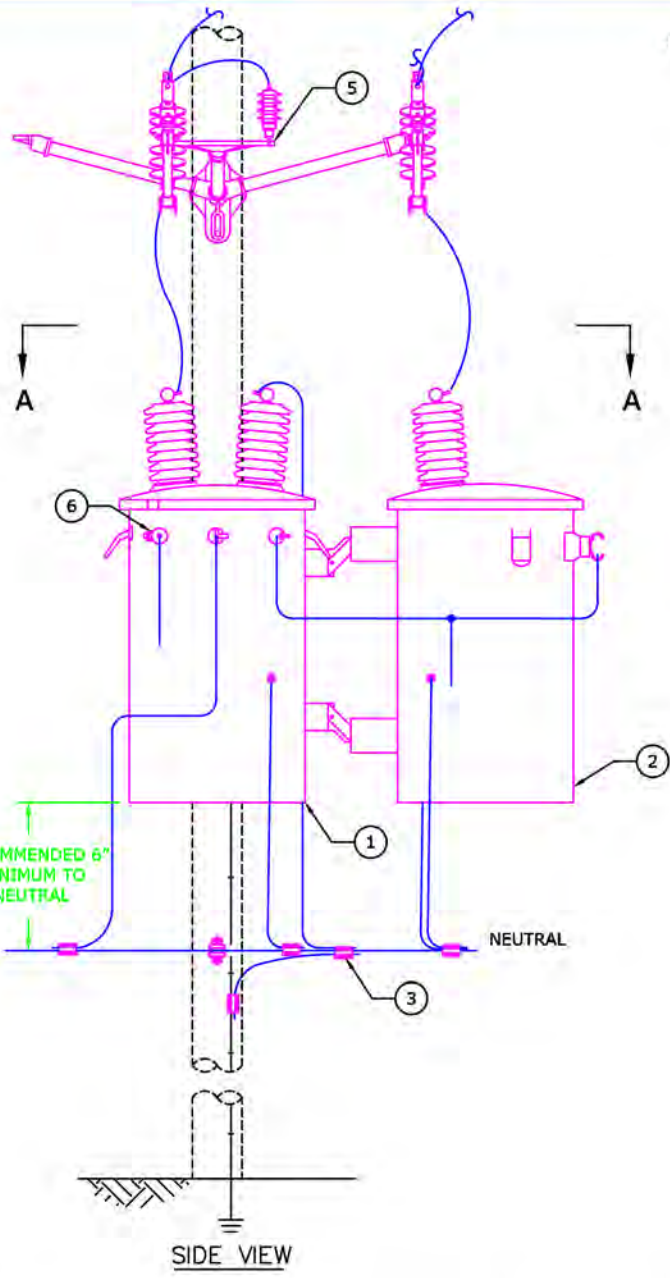

WARNING
DO NOT USE CSP
TRANSFORMERS IN
THIS CONFIGURATION.

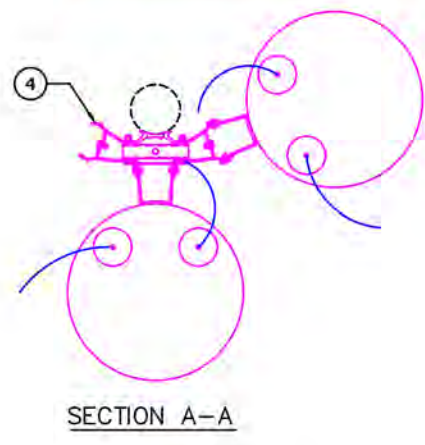

NOTES:

1. BOND TRANSFORMER NEUTRAL AND TRANSFORMER GROUND TO SYSTEM NEUTRAL AND SYSTEM GROUND.
2. PLACE BIRD GUARDS AND USE INSULATED CONDUCTOR ON ALL PRIMARY LEADS.
3. GROUNDS ARE TO STOP AT THE NEUTRAL POSITION EXCEPT TO RISE TO A LIGHTNING ARRESTER OR TRANSFORMER WHEN APPLICABLE.
4. SEE DRAWING MG-11EC FOR CONDUCTOR SIZE.
5. CURRENT LIMITING FUSES AS REQUIRED. SEE DWG. M5-9CLEC.
6. X2 GROUND WIRE SHALL BE #2 BARE COPPER & TANK GROUNDS SHALL BE #6 BARE COPPER.
7. H2 GROUND WIRE SHALL BE #4 INSULATED COPPER.
8. APPARATUS BRACKET AND NEUTRAL HEIGHT MAY VARY DEPENDING ON SIZE OF TRANSFORMER BANK.

DWG REF	QTY	LIST OF MATERIALS	
		DESCRIPTION	STOCK #
1	1	TRANSFORMER, REQUIRED SIZE	-
2	1	TRANSFORMER, REQUIRED SIZE	-
3	-	CONNECTOR	-
4	1	BRACKET, CLUSTER MOUNT	-
5	1	3-PHASE APPARATUS BRACKET	-
6	-	UB-4 OR UB-6 AS NEEDED	-
7	2	CLAMP (NOT SHOWN)	-
8	2	STIRRUP, SIZE AS REQ. (NOT SHOWN)	-

GREENVILLE UTILITIES COMMISSION
 GREENVILLE, NORTH CAROLINA

**TWO TRANSFORMER, 240/120 VOLT
 3-PHASE, 4 WIRE DELTA BANK**



DWN.	JLS	DATE:	11/29/21
CKD.	KW	APPD.	
SCALE:	NONE		
DATE	REVISION	DATE	REVISION

DWG. NO.
G210EC

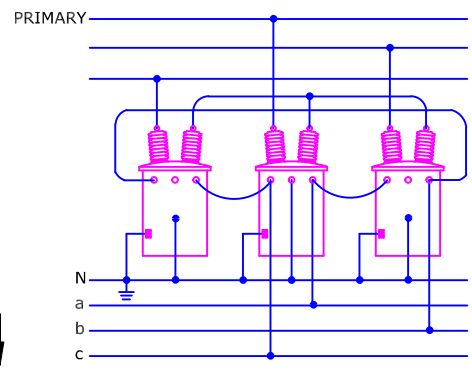
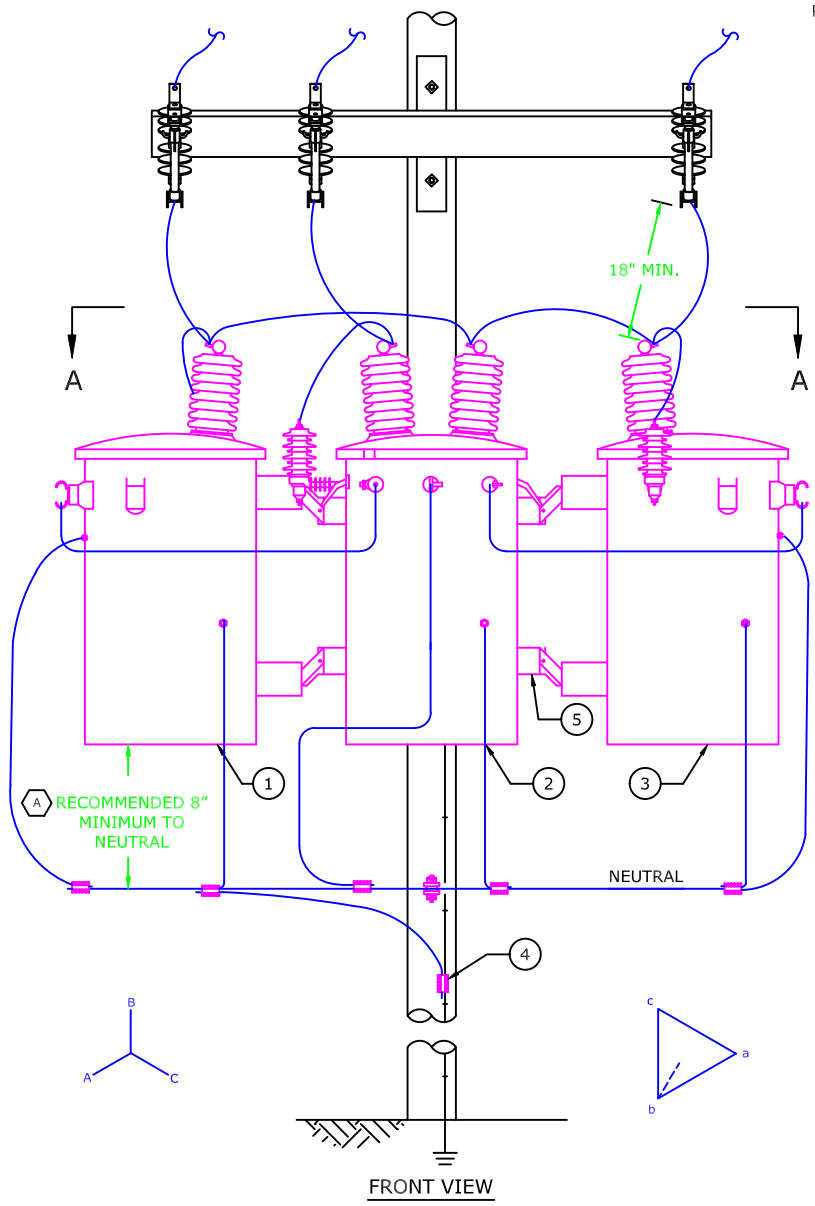

WARNING
DO NOT USE CSP
TRANSFORMERS IN
THIS CONFIGURATION.

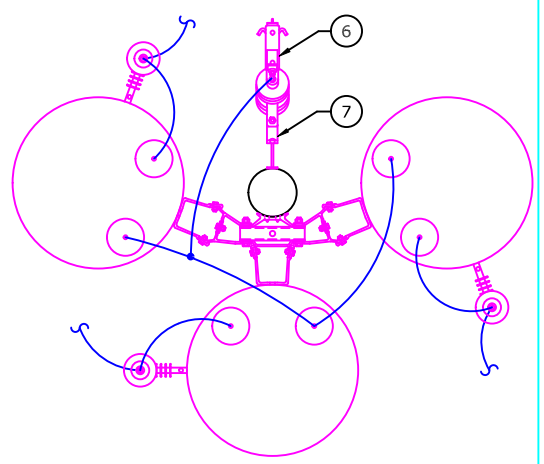

FRONT VIEW

SECTION A-A

NOTES:

1. BOND TRANSFORMER NEUTRAL AND TRANSFORMER GROUND TO SYSTEM NEUTRAL AND SYSTEM GROUND.
 2. PLACE BIRD GUARDS AND USE INSULATED CONDUCTOR ON ALL PRIMARY LEADS.
 3. MAY USE HARDENED SPIN TOP BUSHINGS IN LIEU OF BIRD GUARDS.
 4. GROUNDS ARE TO STOP AT THE NEUTRAL POSITION EXCEPT TO RISE TO A LIGHTNING ARRESTER OR TRANSFORMER WHEN APPLICABLE.
 5. TRANS* DENOTES TRANSFORMER KVA SIZE
 6. DO NOT PERMANENTLY GROUND HIGH SIDE TRANSFORMER NEUTRAL.
 7. INSTALL ADDITIONAL CUTOUT FOR TEMPORARY GROUNDING HIGH SIDE TRANSFORMER NEUTRAL.
 8. SEE DWG. MG-11EC FOR CONDUCTOR SIZE.
 9. SEE DWG. M2-1EC FOR TRANSFORMER GROUNDING.
 10. FUSES AS REQUIRED, SEE DWGS. M5-9EC AND M5-9CLEC.
- (A) PLEASE CONSULT NESIC IF YOU ARE GOING TO MOUNT THE TRANSFORMER AT A DIFFERENT CLEARANCE.

DWG REF	QTY	LIST OF MATERIALS		GREENVILLE UTILITIES COMMISSION GREENVILLE, NORTH CAROLINA					
		DESCRIPTION	STOCK #	THREE TRANSFORMER, 240/120 VOLT 3-PHASE, 4 WIRE DELTA SECONDARY BANK					
1	1	TRANSFORMER, REQUIRED SIZE	-		DWN. DRB DATE: 08/05/2022 CKD. JLS APPD. SCALE: NONE			DWG. NO. G310EC	
2	1	TRANSFORMER, REQUIRED SIZE	-						
3	1	TRANSFORMER, REQUIRED SIZE	-						
4	-	CONNECTOR	-		DATE	REVISION	DATE		REVISION
5	1	BRACKET, CLUSTER MOUNT	-						
6	1	SWITCH, FUSED CUTOUT	-						
7	1	BRACKET, 1PH, CUTOUT/ARRESTER	-						

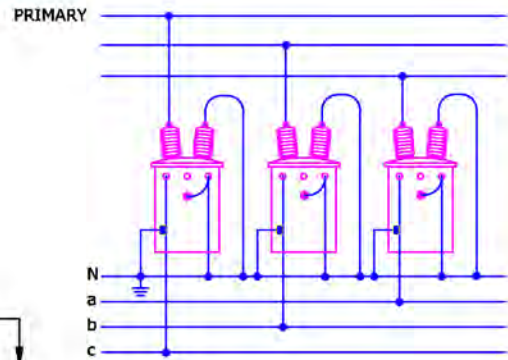
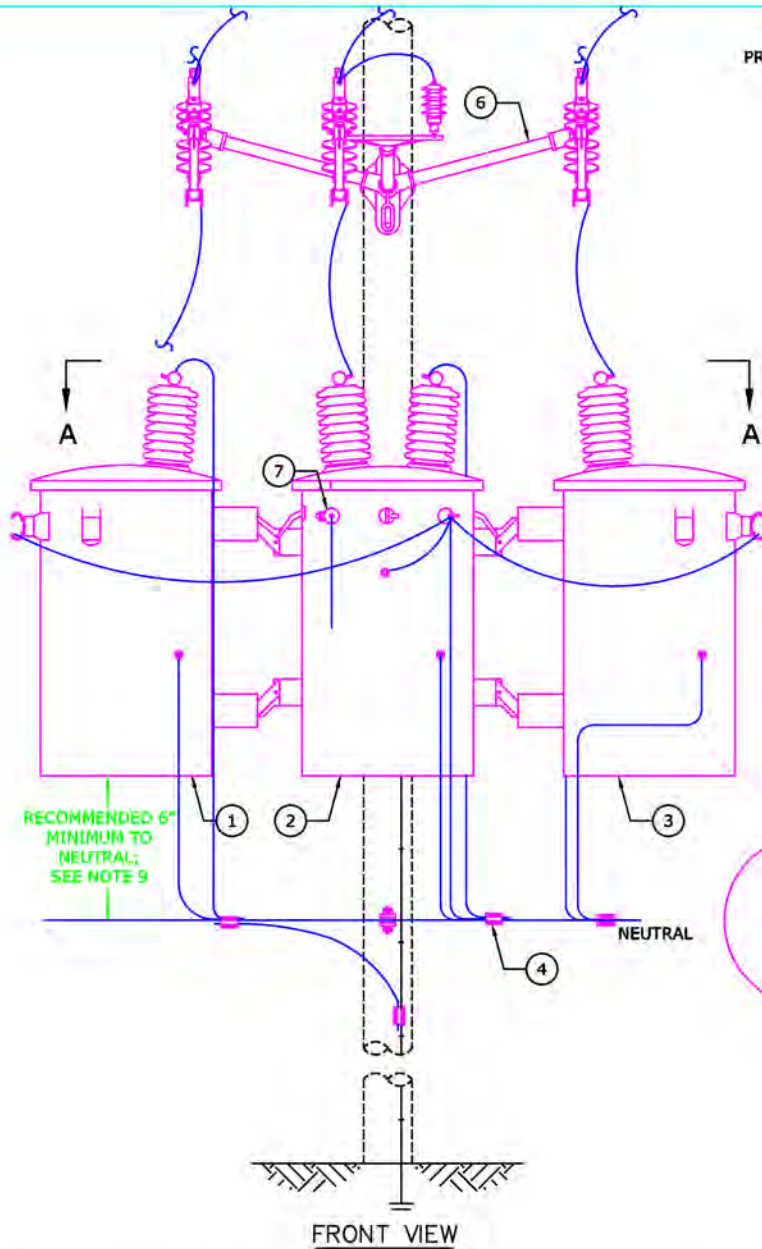

WARNING
DO NOT USE CSP
TRANSFORMERS IN
THIS CONFIGURATION.

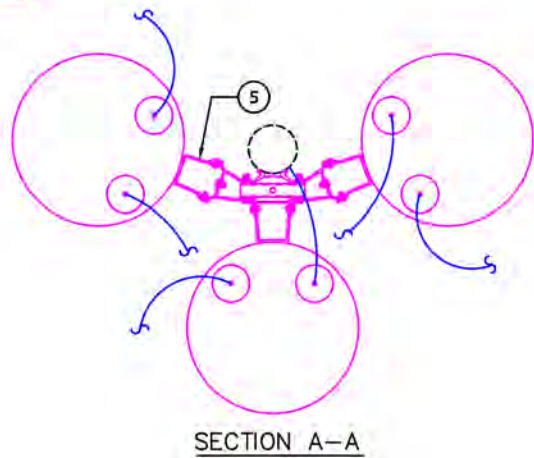

NOTES:

1. BOND TRANSFORMER NEUTRAL AND TRANSFORMER GROUND TO SYSTEM NEUTRAL AND SYSTEM GROUND.
2. PLACE BIRD GUARDS AND USE INSULATED CONDUCTOR ON ALL PRIMARY LEADS.
3. GROUNDS ARE TO STOP AT THE NEUTRAL POSITION EXCEPT TO RISE TO A LIGHTNING ARRESTER OR TRANSFORMER WHEN APPLICABLE.
4. SEE DRAWING MG-11EC FOR CONDUCTOR SIZE.
5. CURRENT LIMITING FUSES AS REQUIRED. SEE DWG. M5-9CLEC.
6. X2 GROUND WIRE SHALL BE #2 BARE COPPER & TANK GROUNDS SHALL BE #6 BARE COPPER.
7. H2 GROUND WIRE SHALL BE #4 INSULATED COPPER.
8. APPARATUS BRACKET AND NEUTRAL HEIGHT MAY VARY DEPENDING ON SIZE OF TRANSFORMER BANK.

DWG REF	QTY	LIST OF MATERIALS		GREENVILLE UTILITIES COMMISSION GREENVILLE, NORTH CAROLINA			
		DESCRIPTION	STOCK #	THREE TRANSFORMER, 208/120 VOLT 3-PHASE, 4 WIRE WYE BANK			
1	1	TRANSFORMER, REQUIRED SIZE	-	 DWN. JLS DATE: 11/29/21 CKD. KW APPD. SCALE: NONE DATE REVISION DATE REVISION	DWG. NO. G312EC		
2	1	TRANSFORMER, REQUIRED SIZE	-				
3	1	TRANSFORMER, REQUIRED SIZE	-				
4	-	CONNECTOR	-				
5	1	BRACKET, CLUSTER MOUNT	-				
6	1	3-PHASE APPARATUS BRACKET	-				
7	-	UB-4 OR UB-6 AS NEEDED	-				
8	3	CLAMP (NOT SHOWN)	-				
9	3	STIRRUP, SIZE AS REQ. (NOT SHOWN)	-				

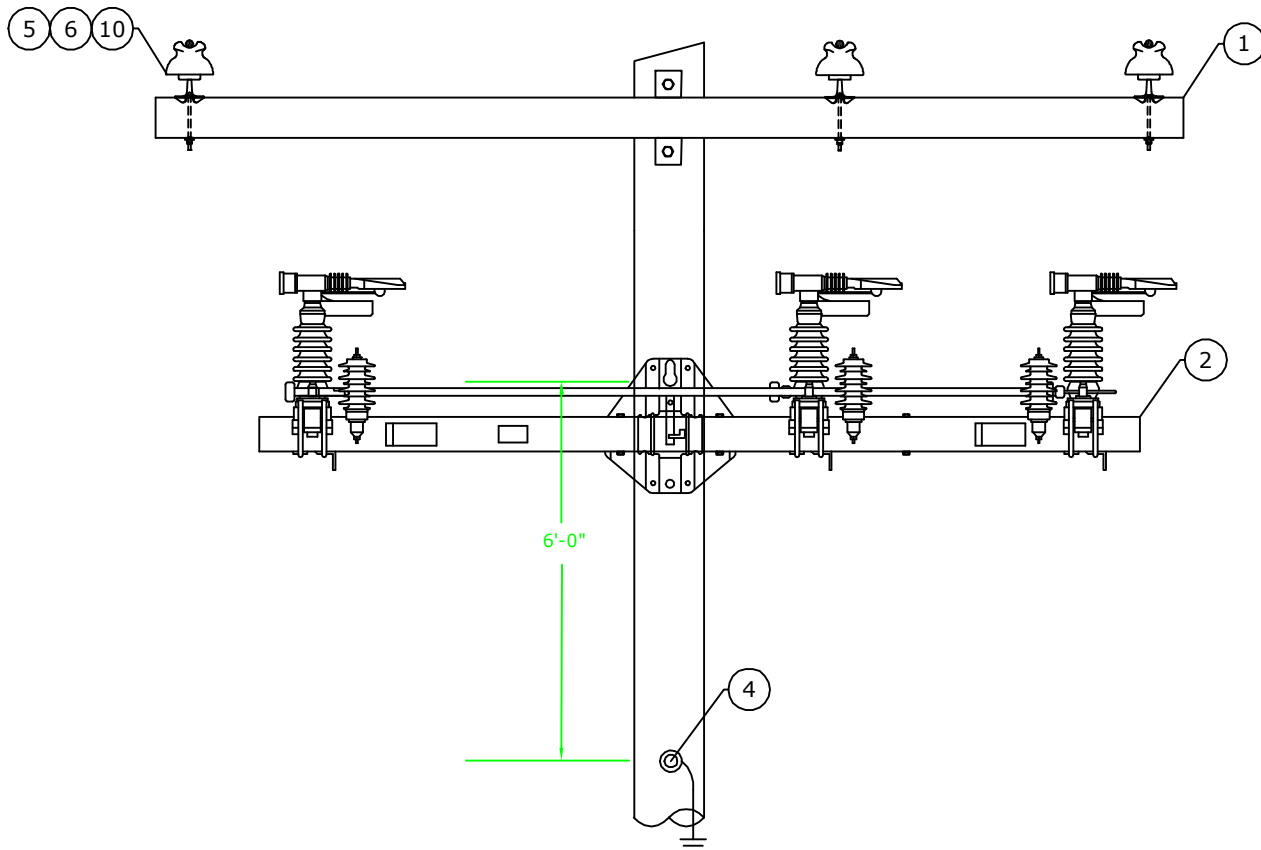

FRONT VIEW

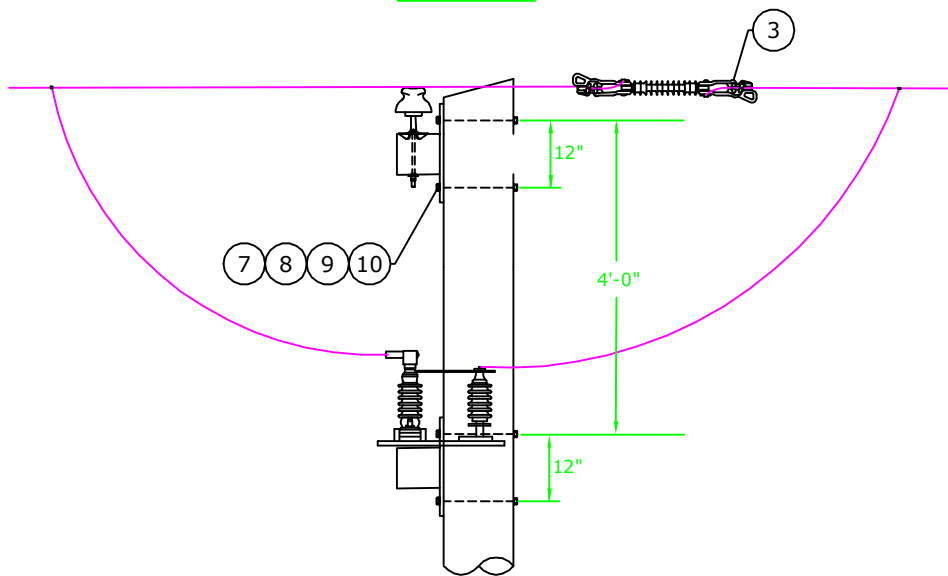

SIDE VIEW

NOTES:

- 1) FIBERGLASS CROSSARM BRACE NOT SHOWN IN DRAWING.

DWG. REF.	LIST OF MATERIALS				GREENVILLE UTILITIES COMMISSION GREENVILLE, NORTH CAROLINA				
	ea.	DESCRIPTION	ITEM	DET.	 HORIZONTAL GANG SWITCH DETAIL				
1	1	10' DISTRIBUTION CROSSARM DE	-	-					DWN. JLS DATE: 11/23/21 CKD. KW APPD. KW
2	1	15 KV HORIZONTAL GANG SWITCH	-	-					
3	3	DEAD END ASSEMBLY, SECONDARY	-	-	SCALE: N.T.S. PAGE 1 OF 1 DATE REVISION DATE REVISION				
4	1	NEUTRAL ASSEMBLY, DEADEND	-	TM-4E					
5	3	25 KV PIN INSULATOR	-	-					
6	3	25 KV PINS, LONG SHANK CROSS	-	-					
7	4	BOLT, MACHINE 5/8" x 20"	-	-					
8	4	SPRING LOCK WASHER, 5/8"	-	-					
9	4	NUT, 5/8"	-	-					
10	7	WASHER, SQUARE, 3 x 3 x 1/4" w/ 13/16"	-	-					

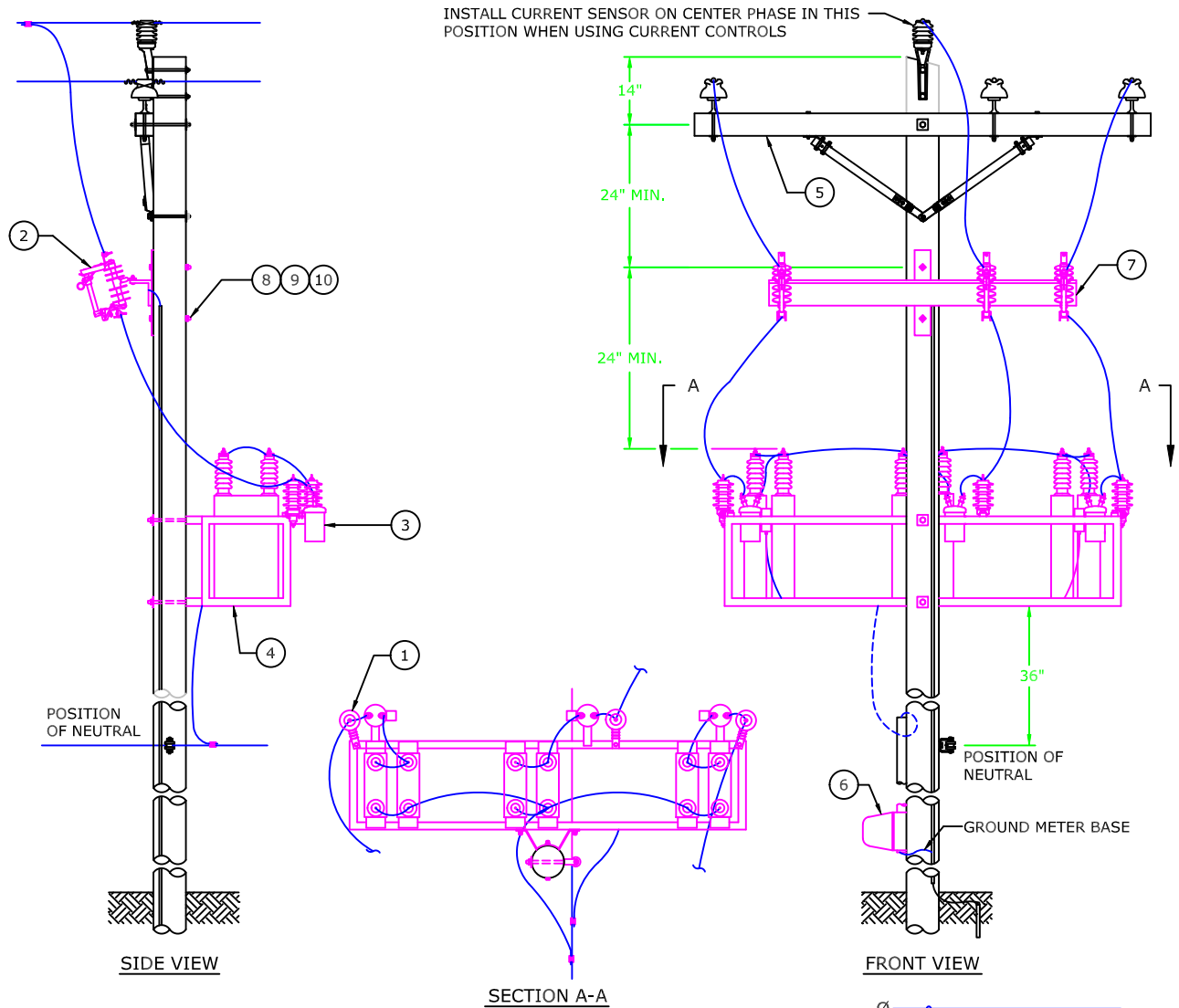

NOTES:

1. TIE NEUTRAL BUSHINGS OF ALL CAPACITORS IN SERIES TOGETHER AND TIE TO SYSTEM IN SERIES TOGETHER AND TIE TO SYSTEM POLE GROUND.
2. GROUND CAPACITOR RACK TO POLE GROUND IN AT LEAST TWO PLACES.
3. SPECIFY INSULATING CAPS FOR PRIMARY TERMINAL BUSHINGS.
4. CURRENT LIMITING FUSES AS REQUIRED. SEE DWG. M5-9CLEC.
5. PLACE BIRD GUARDS AND USE INSULATED CONDUCTOR ON ALL PRIMARY LEADS.
6. MAY USE HARDENED SPIN TOP BUSHING IN LIEU OF BIRD GUARDS.
7. ALL GROUND WIRE SHALL BE #4 BARE COPPER.
8. SEE DWG. M5-6EC FOR ARRESTER INFORMATION.
9. SEE DWG. M2-1EC FOR GROUND ROD DETAIL.

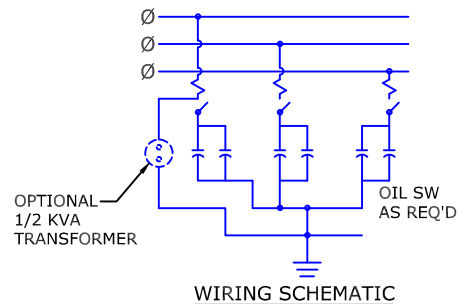

DWG REF	QTY	LIST OF MATERIALS	
		DESCRIPTION	STOCK #
1	3	ARRESTER, INTERMEDIATE	-
2	1	SWITCH, FUSED CUTOUT	-
3	1	SWITCH, OIL	-
4	-	ASSEMBLY, CAPACITOR BANK	-
5	1	CROSSARM, SYP, WOOD	-
6	1	CONTROLLER, CAPACITOR BANK	-
7	1	BRACKET, 3 PH, CUTOUT/ARRESTER	-
8		BOLT, MACHINE	-
9		WASHER, SQUARE FLAT, 2 1/4"	-
10		WASHER, LOCK 5/8"	-

GREENVILLE UTILITIES COMMISSION
GREENVILLE, NORTH CAROLINA

GREENVILLE Utilities

CAPACITOR ASSEMBLY
THREE-PHASE CROSSARM CONSTRUCTION

DWN.	DRB	DATE:	08/05/2022
CKD.	JLS	APPD.	
SCALE: NONE			
DATE	REVISION	DATE	REVISION

DWG. NO.
M9-13EC

Appendix D: Plan & Profile, 22-33461-PP01-A

[Balance of Page Left Blank Intentionally]

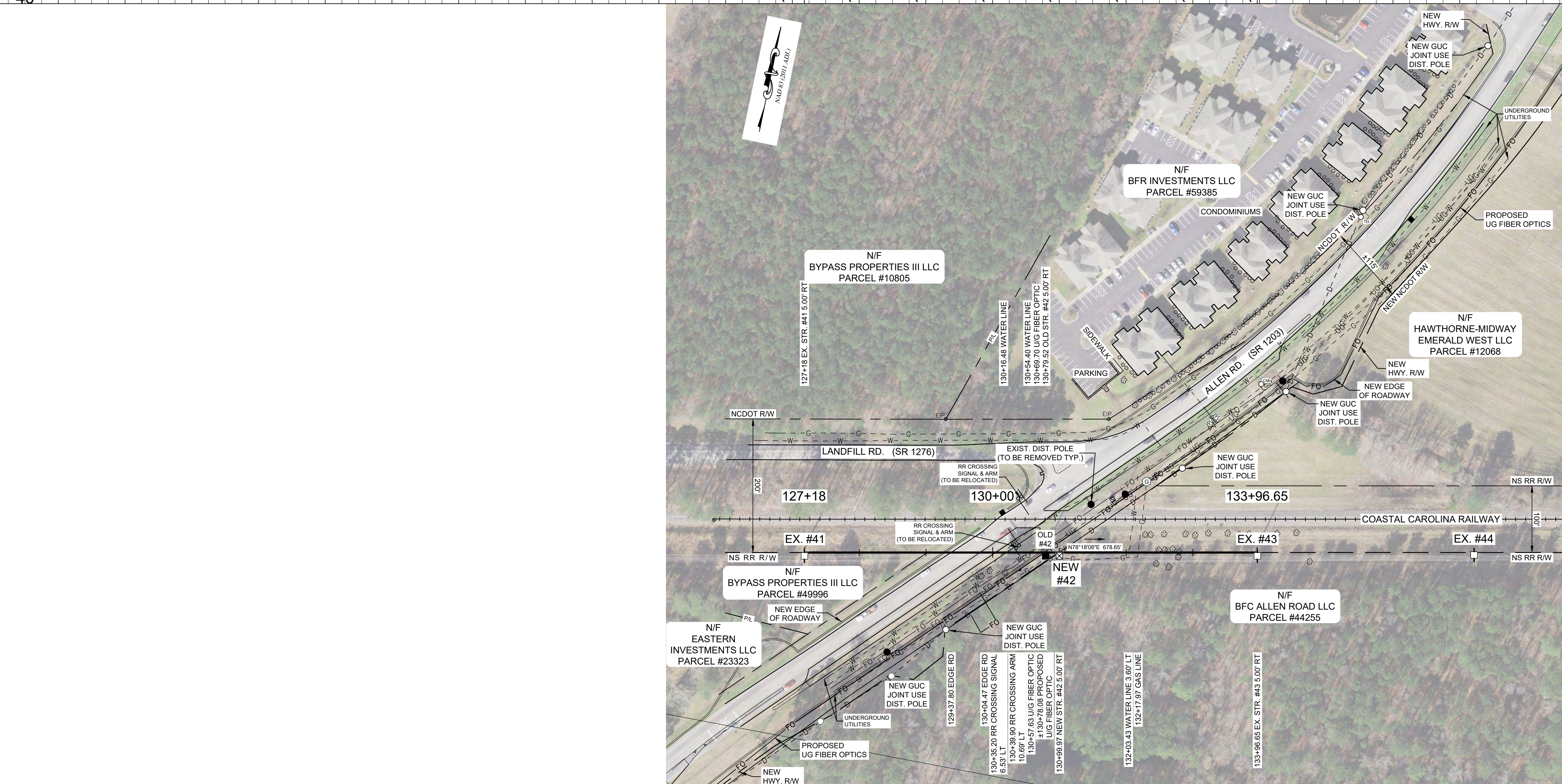
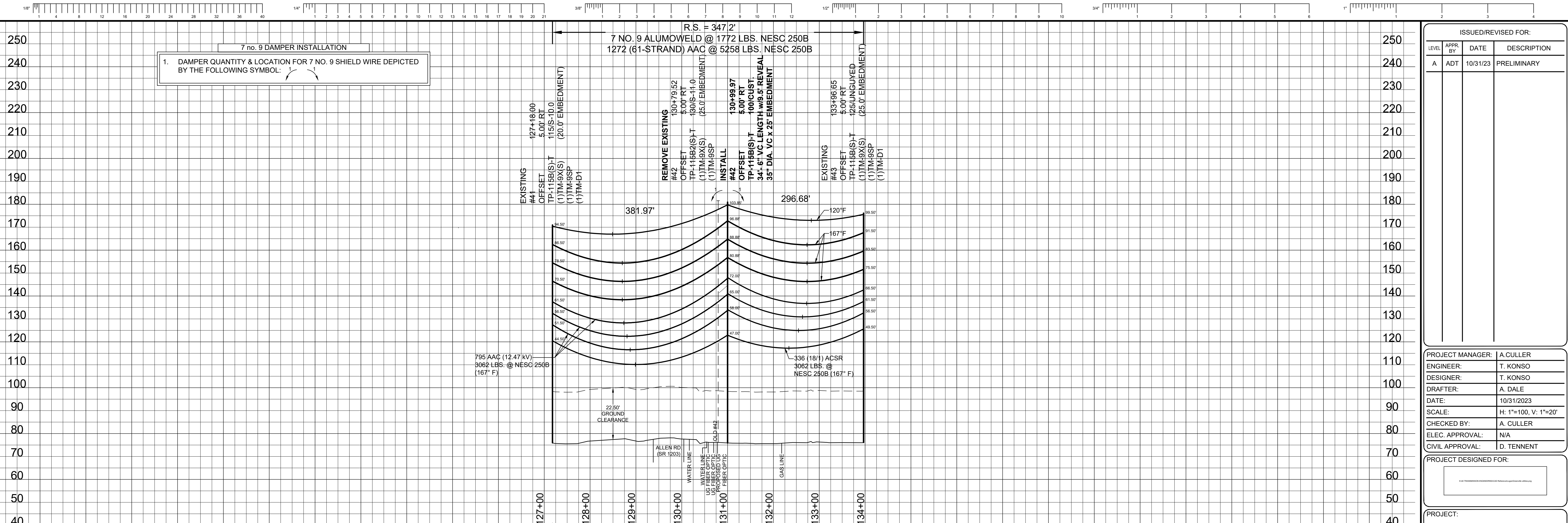

ISSUED/REVISED FOR:			
LEVEL	APPR. BY	DATE	DESCRIPTION
A	ADT	10/31/23	PRELIMINARY

PROJECT MANAGER:	A. CULLER
ENGINEER:	T. KONSO
DESIGNER:	T. KONSO
DRAFTER:	A. DALE
DATE:	10/31/2023
SCALE:	H: 1"=100, V: 1"=20'
CHECKED BY:	A. CULLER
ELEC. APPROVAL:	N/A
CIVIL APPROVAL:	D. TENNENT

PROJECT DESIGNED FOR:	
-----------------------	--

PROJECT:	BLOUNT GOAB TO DICKINSON AVE. SUB. STR. #42 RELOCATION
----------	--

TITLE:
PLAN & PROFILE

PIKE ENGINEERING, LLC
123 NORTH WHITE STREET
FORT MILL, SC 29715
NC License No. F-1217

NOTE:
THE DATA IN THIS DOCUMENT INCORPORATES PROPRIETARY RIGHTS OF PIKE ENGINEERING, LLC. ANY PARTY ACCEPTING THIS DOCUMENT DOES SO IN CONFIDENCE AND AGREES THAT IT SHALL NOT BE DUPLICATED IN WHOLE OR PART, NOR DISCLOSED TO OTHERS WITHOUT THE CONSENT OF PIKE ENGINEERING, LLC.

CONTRACTOR SHALL VERIFY ALL CONDITIONS ON JOB SITE & NOTIFY PROJECT MANAGER OF ANY VARIATIONS FROM DIMENSIONS SHOWN ON THESE DRAWINGS BEFORE PROCEEDING WITH ANY CONSTRUCTION.

SEAL

SEAL

NOTE: SEE DISTRIBUTION DESIGN FOR SAG CHARTS & MATERIAL INSTALLATIONS

ISSUED FOR BID

PROJECT NUMBER		
33461-000		
DRAWING No.	REV.	
PP01	01	A

Appendix E: Pole Assembly Drawing, 22-33461-SK01-01

[Balance of Page Left Blank Intentionally]

ASSEMBLY LIST

KEY	QTY.	DESCRIPTION	DETAIL
1	1	OHWG SUSPENSION CLAMP	TM-4A
2	1	GROUNDING ASSEMBLY FOR STEEL POLES	TM-9
3	1	CUSTOM POLE WITH TAPERED VC FDN.	-
4	3	INSULATOR ASSEMBLIES, POLYMER LINE POST	TM-3DM
5	3	10' FIBERGLASS CROSS-ARMS	-
6	6	35 kV VERT. POST INSULATORS	-
7	3	35 kV HORIZ. POST INSULATORS	-
8	2	NEUTRAL ASSEMBLIES	NS-1
9	1	NEUTRAL GROUND ASSEMBLY	NG-1
10	1	OHWG GROUNDING ASSEMBLY	TM-9X(S)

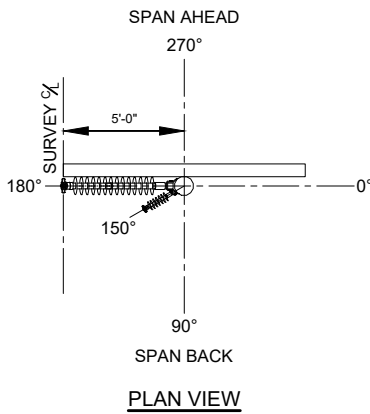

NOTE:
VIEW LOOKING AHEAD SPAN.
REFER TO POLE BID DRAWING
FOR HOLE PATTERNS AND
ORIENTATION.

NOTE:
SEE 1201-02 FOR VIBRATORY
POLE BASE FOUNDATION
(TMF-VPB)

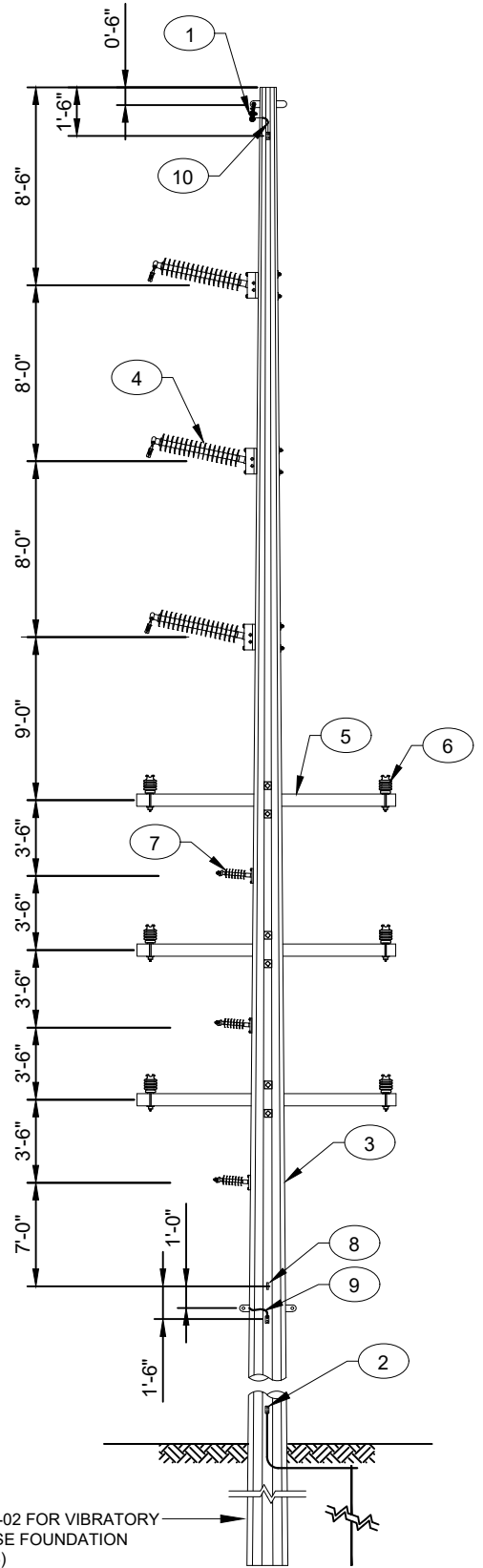

NOTE:

- ALL DIMENSIONS SHOWN ARE TO CENTER OF FIXTURE BOLT PATTERN.

NOTICE:
THE DATA IN THIS DOCUMENT INCORPORATES PROPRIETARY RIGHTS OF PIKE ENGINEERING, LLC. ANY PARTY ACCEPTING THIS DOCUMENT DOES SO IN CONFIDENCE AND AGREES THAT IT SHALL NOT BE DUPLICATED IN WHOLE OR PART, NOR DISCLOSED TO OTHERS WITHOUT THE CONSENT OF PIKE ENGINEERING, LLC.

CONTRACTOR SHALL VERIFY ALL CONDITIONS ON JOB SITE & NOTIFY PROJECT MANAGER OF ANY VARIATIONS FROM DIMENSIONS SHOWN ON THESE DRAWINGS BEFORE PROCEEDING WITH ANY CONSTRUCTION.

ISSUED/REVISED FOR:			
LVL.	APPR. BY	DATE	DESCRIPTION
A	ADT	10/12/23	ISSUED FOR REVIEW
B	ADT	10/27/23	ISSUED FOR REVIEW
C	ADT	11/09/23	ISSUED FOR REVIEW
D	ADT	02/12/24	UPDATED STATIC & NEUTRAL VANGS TO 5/8" THICKNESS

PROJECT ENGINEER:	K.A.C.
ENGINEER:	T.H.K
DESIGNER:	T.H.K
DRAFTER:	T.H.K
DATE:	11/09/23
SCALE:	NTS
CHECKED BY:	K.A.C.
ELEC. APPROVAL:	N/A
CIVIL APPROVAL:	N/A

PIKE ENGINEERING, LLC
123 NORTH WHITE STREET
FORT MILL, SC 29715
NC License No. F-1217

PROJECT DESIGNED FOR:

STRUCTURE NAME:	TP-115B (STR.42)
DRAWING TITLE:	TRANSMISSION POLE ASSEMBLY DRAWING
PROJECT NUMBER:	33461-000
DRAWING No. SEC REV	SK 01 D

Appendix F: Pole Bid Drawings STR. NO. 42, 22-33461-1201-01

[Balance of Page Left Blank Intentionally]

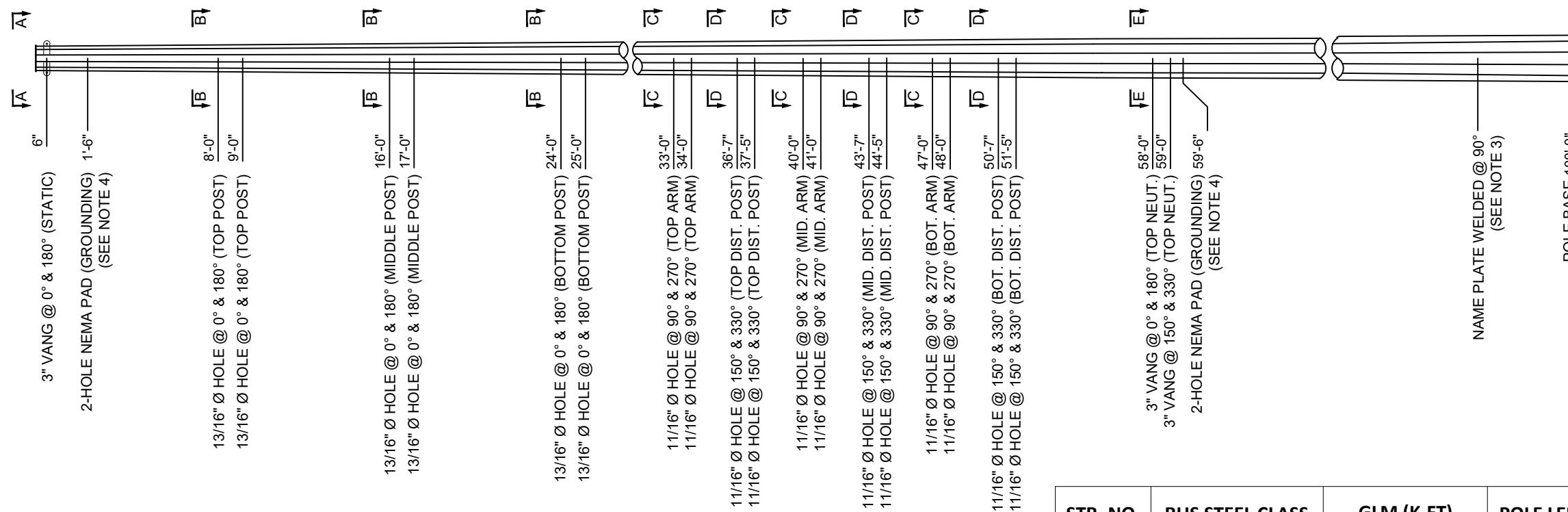

NOTE:
SLIP FIT VIBRATORY POLE
BASE TO BE DESIGNED BY
POLE MANUFACTURER,
SEE DWG. #SK-02.

STR. NO.	RUS STEEL CLASS	GLM (K-FT)	POLE LEN.	VIB. BASE	VC EMBED	VC REVEAL
42	S-13.0	1300 MIN.	100'	35.0" DIA.	25'-0"	9'-6"

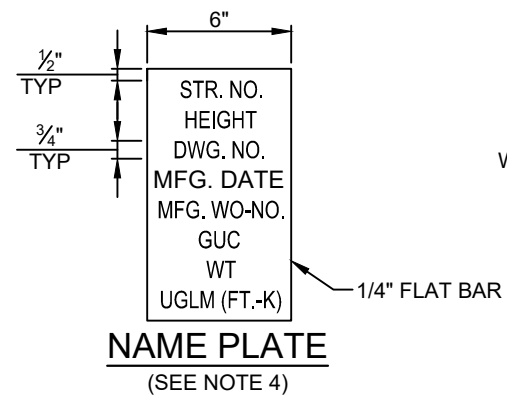
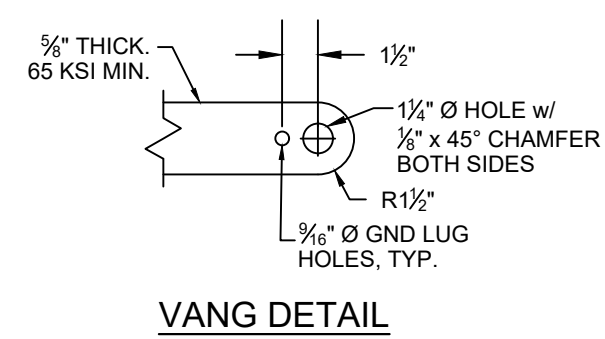
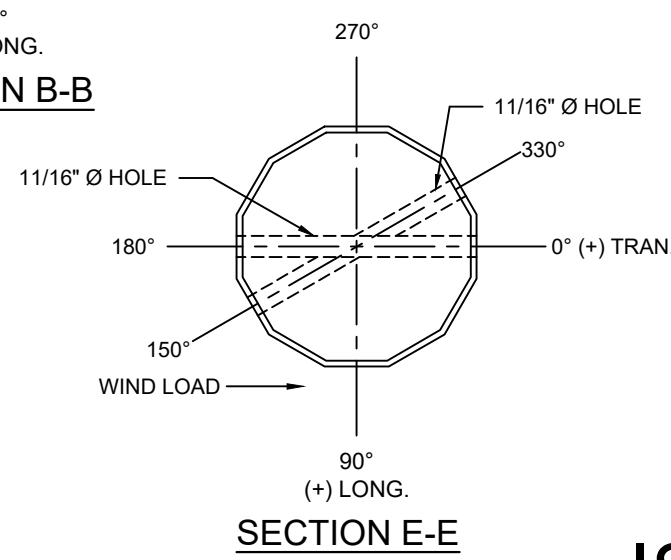
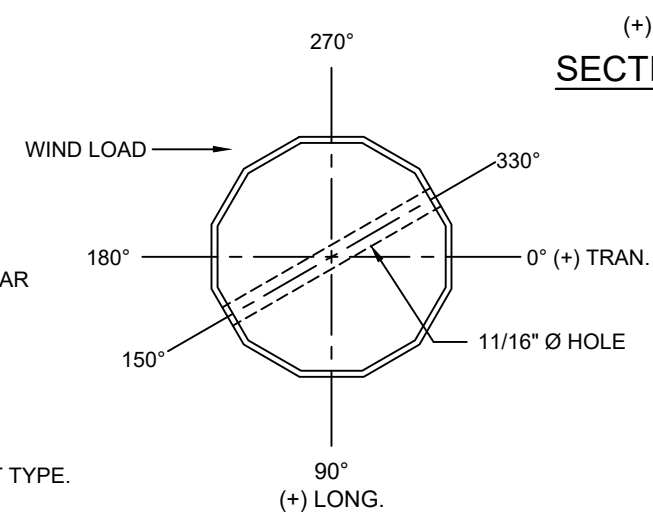
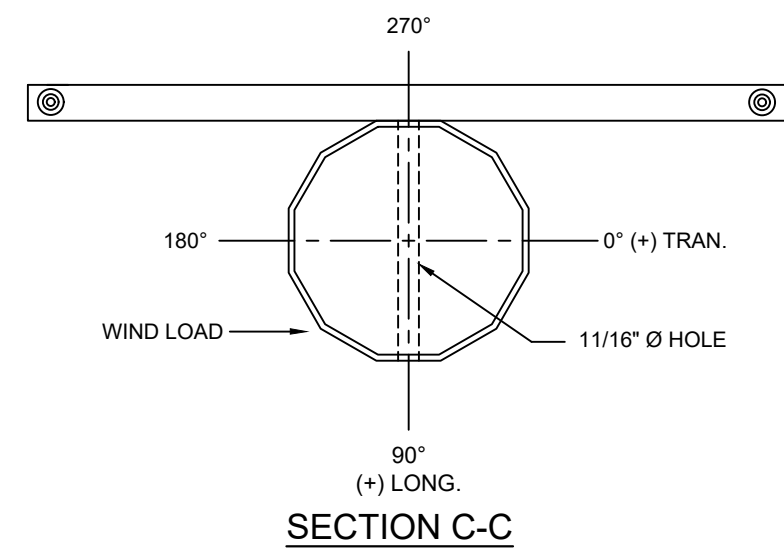
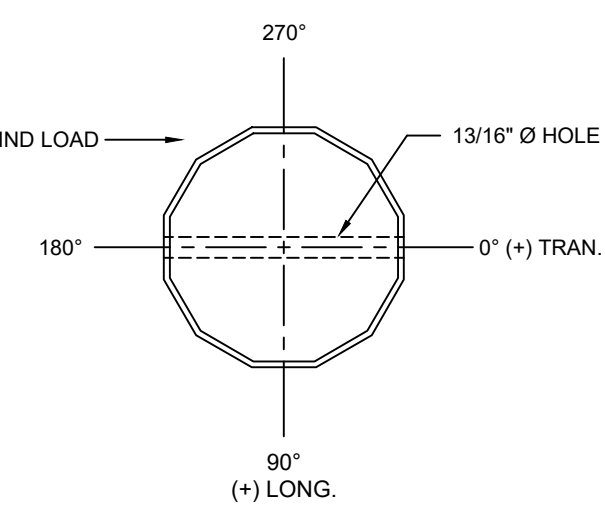
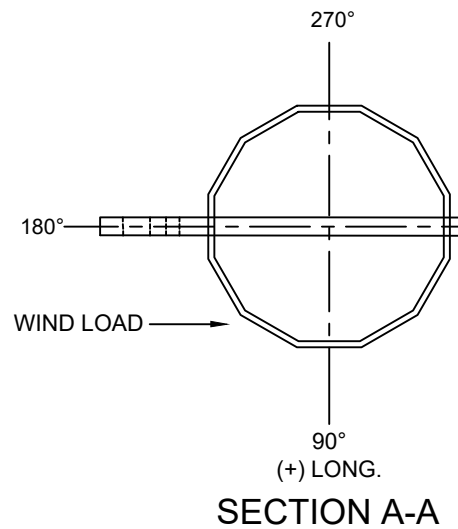
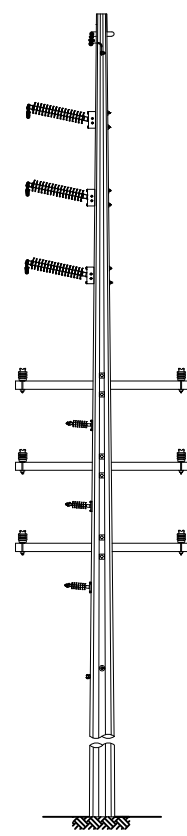

- NOTES:**
1. STRUCTURE SHALL BE DESIGNED IN ACCORDANCE WITH THE LATEST REVISION OF GUC STEEL POLE SPECIFICATIONS.
 2. POLE SHALL BE GALVANIZED STEEL. POLE SPLICES SHALL BE SLIP JOINT TYPE.
 3. NAME PLATE TO BE LOCATED 5'-0" ABOVE GROUND.
 4. NEMA PAD SHALL BE DRILLED AND TAPPED 1/2"-13 UNC, 3/4" DEEP.
 5. FINAL POLE AND TAPERED VC DETAILS TO BE CONFIRMED BY POLE VENDOR. INCLUDE METHOD 4 PLS CADD BAK FILE OF POLE MODEL FOR REVIEW AND APPROVAL.

ISSUED FOR BID

ISSUED/REVISED FOR:			
LEVEL	APPR. BY	DATE	DESCRIPTION
A	ADT	10/12/23	ISSUED FOR REVIEW
B	ADT	10/27/23	ISSUED FOR REVIEW
C	ADT	11/09/23	ISSUED FOR REVIEW
D	ADT	02/12/24	UPDATED STATIC & NEUTRAL VANGS THICKNESS TO 5/8"

PROJECT MANAGER:	KAC
ENGINEER:	THK
DESIGNER:	THK
DRAFTER:	JRR
DATE:	11/09/2023
SCALE:	None
CHECKED BY:	KAC
ELEC. APPROVAL:	N/A
CIVIL APPROVAL:	ADT



PROJECT:
NCDOT U-5875 RELOCATION

TITLE:
TRANSMISSION POLE
BID DRAWINGS
STR. NO. 42



NOTICE:
THE DATA IN THIS DOCUMENT INCORPORATES PROPRIETARY RIGHTS OF PIKE ENGINEERING, LLC. ANY PARTY ACCEPTING THIS DOCUMENT DOES SO IN CONFIDENCE AND AGREES THAT IT SHALL NOT BE DUPLICATED IN WHOLE OR PART, NOR DISCLOSED TO OTHERS WITHOUT THE CONSENT OF PIKE ENGINEERING, LLC.

CONTRACTOR SHALL VERIFY ALL CONDITIONS ON JOB SITE & NOTIFY PROJECT MANAGER OF ANY VARIATIONS FROM DIMENSIONS SHOWN ON THESE DRAWINGS BEFORE PROCEEDING WITH ANY CONSTRUCTION.

SEAL	
SEAL	

PROJECT NUMBER	33461-000
DRAWING	SEQ. No. REV.
	1201 01 D

Appendix G: Pole Bid Drawings STR. NO. 42, 22-33461-1201-02

[Balance of Page Left Blank Intentionally]

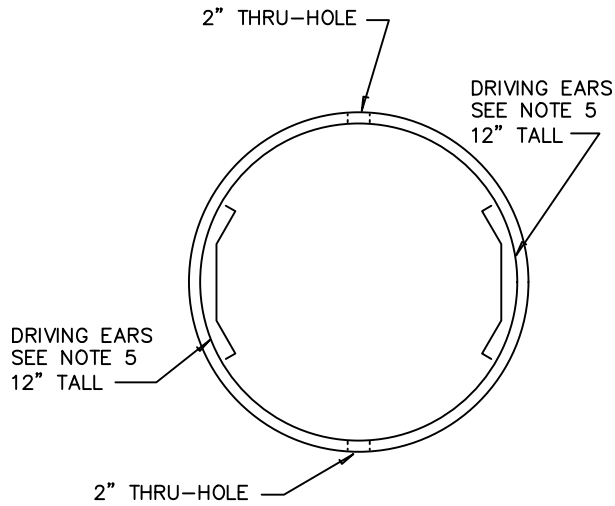

SECTION A-A
N.T.S

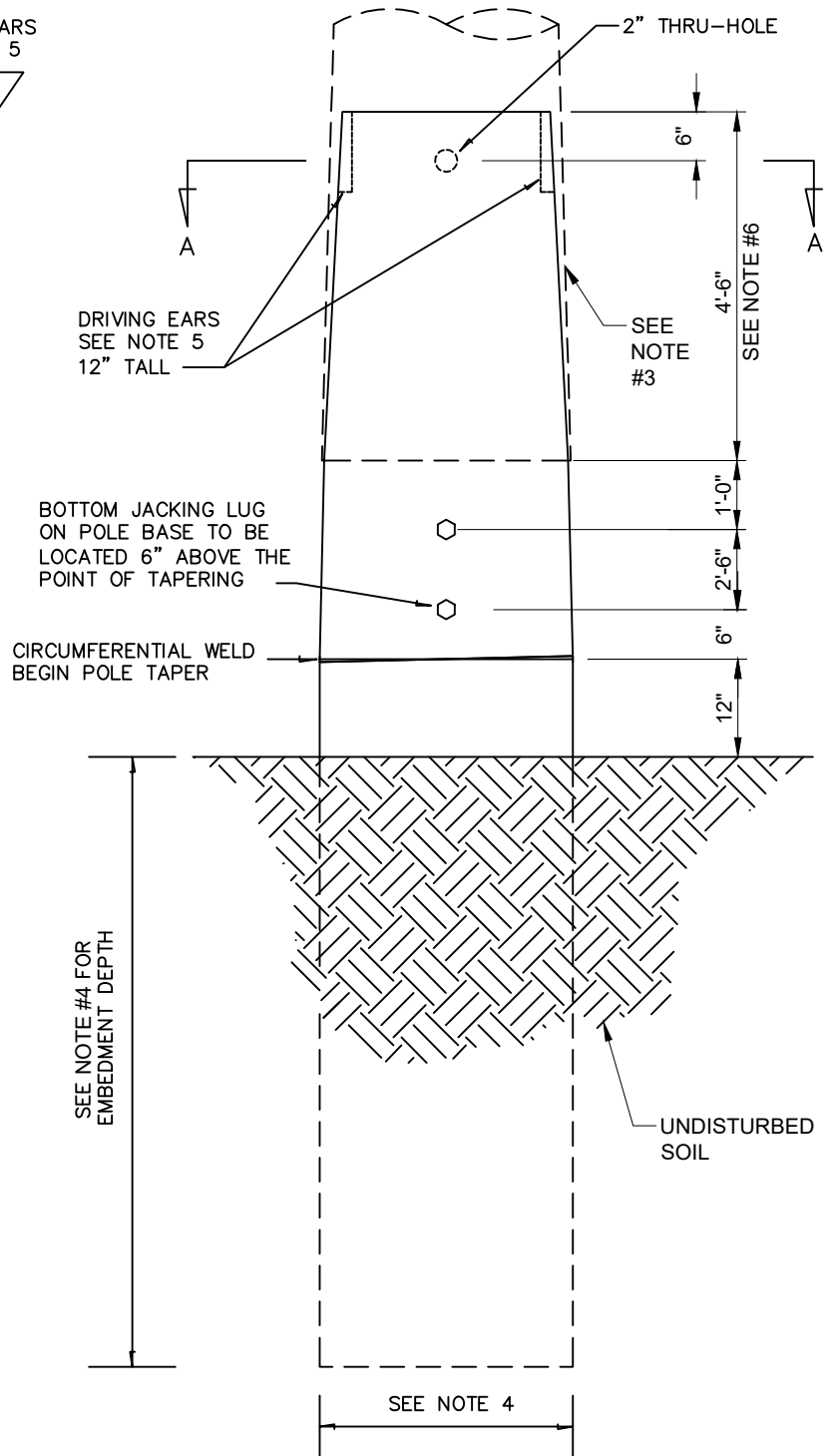

NOTES:

1. VIBRATORY POLE BASE TO BE INSTALLED USING VIBRATORY HAMMER. THE FREQUENCY AND STROKE AMPLITUDE RANGES FOR INSTALLATION OF THE POLE BASE TO BE PER MANUFACTURERS RECOMMENDATIONS.
2. TAPER OF POLE TO MATCH TAPER OF VIBRATORY POLE BASE.
3. OVERLAP LENGTH TO BE DETERMINED BY MANUFACTURER.
4. VIBRATORY BASE DIAMETERS AND DEPTHS SHOWN ON POLE BID DWG. #1201-01 ARE MINIMUM. POLE MANUFACTURER IS TO VERIFY VIBRATORY POLE BASE IS ADEQUATE FOR DESIGN LOADS. MINIMUM SHAFT THICKNESS OF 0.375" AND GRADE OF 65 KSI.
5. MANUFACTURER SHALL DETERMINE ADEQUATE SIZE OF DRIVING EARS.
6. POLE MANUFACTURER TO VERIFY ABOVE GROUND HEIGHT TO BE 105' MINIMUM.

ISSUED FOR BID

NOTICE:
THE DATA IN THIS DOCUMENT INCORPORATES PROPRIETARY RIGHTS OF PIKE ENGINEERING, LLC. ANY PARTY ACCEPTING THIS DOCUMENT DOES SO IN CONFIDENCE AND AGREES THAT IT SHALL NOT BE DUPLICATED IN WHOLE OR PART, NOR DISCLOSED TO OTHERS WITHOUT THE CONSENT OF PIKE ENGINEERING, LLC.

CONTRACTOR SHALL VERIFY ALL CONDITIONS ON JOB SITE & NOTIFY PROJECT MANAGER OF ANY VARIATIONS FROM DIMENSIONS SHOWN ON THESE DRAWINGS BEFORE PROCEEDING WITH ANY CONSTRUCTION.

ISSUED/REVISED FOR:			
LVL.	APPR BY	DATE	DESCRIPTION
A	ADT	10/12/23	ISSUED FOR REVIEW
B	ADT	10/27/23	ISSUED FOR REVIEW
C	ADT	11/09/23	ISSUED FOR REVIEW

PROJECT ENGINEER:	K.A.C.
ENGINEER:	T.H.K.
DESIGNER:	T.H.K.
DRAFTER:	J.R.R.
DATE:	11/09/23
SCALE:	NTS
CHECKED BY:	K.A.C.
ELEC. APPROVAL:	N/A
CIVIL APPROVAL:	N/A

STRUCTURE NAME:	TMF-VPB
DRAWING TITLE:	TRANSMISSION POLE BID DRAWINGS STR. NO. 42
PROJECT NUMBER:	33461-000
DRAWING No.:	1201
REV No.:	02
REV:	C

Appendix H: Sag-Tension Charts

[Balance of Page Left Blank Intentionally]

CLIENT :ELECTRICITIES OF NORTH CAROLINA
 TRANSMISSION LINE :DISTRIBUTION CONDUCTOR SAG DATA
 JOB NUMBER :96-4385-0001
 DATE :04-29-1996

***** INITIAL STRINGING SAG TABLE *****

CONDUCTOR DESCRIPTION :795 MCM (1350)
 LOADING DISTRICT :MEDIUM
 DESIGN TENSION : 35.9 % ULTIMATE 13900 LBS.
 RULING SPAN : 150.00 FT

SAG IS GIVEN IN INCHES ,TO THE NEAREST INCH ,FOR EACH SPAN
 AND TEMPERATURE ,BASED UPON NO ICE LOAD.

TEMPERATURE - DEGREES F

	32	40	50	60	70	80	90
	---	---	---	---	---	---	---
SPAN	SPAN SAG - INCHES						

100.	3.	4.	4.	5.	6.	7.	8.
110.	4.	4.	5.	6.	7.	8.	10.
120.	5.	5.	6.	7.	9.	10.	12.
130.	5.	6.	7.	8.	10.	12.	14.
140.	6.	7.	8.	10.	12.	14.	16.
150.	7.	8.	9.	11.	13.	16.	18.
160.	8.	9.	11.	13.	15.	18.	21.
170.	9.	10.	12.	14.	17.	20.	24.
180.	10.	12.	14.	16.	19.	23.	27.
190.	12.	13.	15.	18.	21.	25.	30.
200.	13.	14.	17.	20.	24.	28.	33.
210.	14.	16.	19.	22.	26.	31.	36.
220.	15.	17.	20.	24.	29.	34.	40.
230.	17.	19.	22.	26.	31.	37.	43.
240.	18.	21.	24.	29.	34.	40.	47.
250.	20.	22.	26.	31.	37.	44.	51.
260.	22.	24.	28.	34.	40.	47.	56.
270.	23.	26.	31.	36.	43.	51.	60.
280.	25.	28.	33.	39.	46.	55.	64.
290.	27.	30.	35.	42.	50.	59.	69.
TENSION							
LBS.	3476.	3113.	2673.	2261.	1897.	1598.	1366.

CLIENT :ELECTRICITIES OF NORTH CAROLINA
 TRANSMISSION LINE :DISTRIBUTION CONDUCTOR SAG DATA
 JOB NUMBER :96-4385-0001
 DATE :04-29-1996

***** INITIAL STRINGING SAG TABLE *****

CONDUCTOR DESCRIPTION :795 MCM (1350)
 LOADING DISTRICT :MEDIUM
 DESIGN TENSION : 35.9 % ULTIMATE 13900 LBS.
 RULING SPAN : 200.00 FT

SAG IS GIVEN IN INCHES ,TO THE NEAREST INCH ,FOR EACH SPAN
 AND TEMPERATURE ,BASED UPON NO ICE LOAD.

TEMPERATURE - DEGREES F

	32	40	50	60	70	80	90
	--	--	--	--	--	--	--

SPAN SAG - INCHES

100.	3.	3.	4.	4.	5.	6.	7.
110.	4.	4.	5.	5.	6.	7.	8.
120.	4.	5.	5.	6.	7.	8.	10.
130.	5.	6.	6.	7.	9.	10.	11.
140.	6.	7.	7.	9.	10.	11.	13.
150.	7.	7.	9.	10.	11.	13.	15.
160.	8.	9.	10.	11.	13.	15.	17.
170.	9.	10.	11.	13.	15.	17.	19.
180.	10.	11.	12.	14.	16.	19.	21.
190.	11.	12.	14.	16.	18.	21.	24.
200.	12.	13.	15.	18.	20.	23.	26.
210.	13.	15.	17.	19.	22.	26.	29.
220.	15.	16.	18.	21.	24.	28.	32.
230.	16.	18.	20.	23.	27.	31.	35.
240.	17.	19.	22.	25.	29.	33.	38.
250.	19.	21.	24.	27.	31.	36.	41.
260.	20.	23.	26.	30.	34.	39.	45.
270.	22.	24.	28.	32.	37.	42.	48.
280.	24.	26.	30.	34.	40.	45.	52.
290.	25.	28.	32.	37.	42.	49.	56.

TENSION							
LBS.	3693.	3352.	2941.	2558.	2218.	1930.	1696.

CLIENT :ELECTRICITIES OF NORTH CAROLINA
 TRANSMISSION LINE :DISTRIBUTION CONDUCTOR SAG DATA
 JOB NUMBER :96-4385-0001
 DATE :04-29-1996

***** INITIAL STRINGING SAG TABLE *****

CONDUCTOR DESCRIPTION :795 MCM (1350)
 LOADING DISTRICT :MEDIUM
 DESIGN TENSION : 35.9 % ULTIMATE 13900 LBS.
 RULING SPAN : 250.00 FT

SAG IS GIVEN IN INCHES ,TO THE NEAREST INCH ,FOR EACH SPAN
 AND TEMPERATURE ,BASED UPON NO ICE LOAD.

TEMPERATURE - DEGREES F

32 40 50 60 70 80 90
 -- -- -- -- -- -- --

SPAN SPAN SAG - INCHES

	32	40	50	60	70	80	90
150.	7.	7.	8.	9.	10.	12.	13.
160.	8.	8.	9.	11.	12.	13.	15.
170.	9.	9.	11.	12.	13.	15.	17.
180.	10.	11.	12.	13.	15.	17.	19.
190.	11.	12.	13.	15.	17.	19.	21.
200.	12.	13.	15.	16.	19.	21.	23.
210.	13.	14.	16.	18.	20.	23.	26.
220.	14.	16.	18.	20.	22.	25.	28.
230.	16.	17.	19.	22.	24.	28.	31.
240.	17.	19.	21.	24.	27.	30.	33.
250.	18.	20.	23.	26.	29.	33.	36.
260.	20.	22.	25.	28.	31.	35.	39.
270.	22.	24.	27.	30.	34.	38.	42.
280.	23.	25.	29.	32.	36.	41.	45.
290.	25.	27.	31.	35.	39.	44.	49.
300.	27.	29.	33.	37.	42.	47.	52.
310.	28.	31.	35.	39.	44.	50.	56.
320.	30.	33.	37.	42.	47.	53.	59.
330.	32.	35.	40.	45.	50.	57.	63.
340.	34.	38.	42.	47.	53.	60.	67.

TENSION
 LBS. 3775. 3456. 3076. 2727. 2418. 2152. 1931.

CLIENT : ELECTRICITIES OF NORTH CAROLINA
 TRANSMISSION LINE : DISTRIBUTION CONDUCTOR SAG DATA
 JOB NUMBER : 96-4385-0001
 DATE : 04-29-1996

***** INITIAL STRINGING SAG TABLE *****

CONDUCTOR DESCRIPTION : 336.4 MCM 18/1 ACSR
 LOADING DISTRICT : MEDIUM
 DESIGN TENSION : 34.5 % ULTIMATE 8680 LBS.
 RULING SPAN : 150.00 FT

SAG IS GIVEN IN INCHES , TO THE NEAREST INCH , FOR EACH SPAN
 AND TEMPERATURE , BASED UPON NO ICE LOAD.

TEMPERATURE - DEGREES F

SPAN	TEMPERATURE - DEGREES F						
	32	40	50	60	70	80	90
100.	2.	3.	3.	4.	4.	5.	6.
110.	3.	3.	4.	4.	5.	6.	7.
120.	4.	4.	4.	5.	6.	7.	9.
130.	4.	5.	5.	6.	7.	8.	10.
140.	5.	5.	6.	7.	8.	10.	12.
150.	6.	6.	7.	8.	9.	11.	13.
160.	6.	7.	8.	9.	11.	13.	15.
170.	7.	8.	9.	10.	12.	14.	17.
180.	8.	9.	10.	11.	13.	16.	19.
190.	9.	10.	11.	13.	15.	18.	21.
200.	10.	11.	12.	14.	17.	20.	24.
210.	11.	12.	13.	16.	18.	22.	26.
220.	12.	13.	15.	17.	20.	24.	29.
230.	13.	14.	16.	19.	22.	26.	31.
240.	14.	15.	18.	20.	24.	29.	34.
250.	15.	17.	19.	22.	26.	31.	37.
260.	17.	18.	21.	24.	28.	34.	40.
270.	18.	19.	22.	26.	30.	36.	43.
280.	19.	21.	24.	28.	33.	39.	46.
290.	21.	22.	26.	30.	35.	42.	50.
TENSION LBS.	2232.	2041.	1799.	1558.	1325.	1109.	924.

CLIENT : ELECTRICITIES OF NORTH CAROLINA
 TRANSMISSION LINE : DISTRIBUTION CONDUCTOR SAG DATA
 JOB NUMBER : 96-4385-0001
 DATE : 04-29-1996

***** INITIAL STRINGING SAG TABLE *****

CONDUCTOR DESCRIPTION : 336.4 MCM 18/1 ACSR
 LOADING DISTRICT : MEDIUM
 DESIGN TENSION : 34.5 % ULTIMATE 8680 LBS.
 RULING SPAN : 200.00 FT

SAG IS GIVEN IN INCHES , TO THE NEAREST INCH , FOR EACH SPAN AND TEMPERATURE , BASED UPON NO ICE LOAD.

TEMPERATURE - DEGREES F

SPAN	TEMPERATURE - DEGREES F						
	32	40	50	60	70	80	90

	SPAN SAG - INCHES						

100.	2.	3.	3.	3.	4.	4.	5.
110.	3.	3.	3.	4.	5.	5.	6.
120.	3.	4.	4.	5.	5.	6.	7.
130.	4.	4.	5.	6.	6.	7.	9.
140.	5.	5.	6.	6.	7.	9.	10.
150.	5.	6.	6.	7.	9.	10.	11.
160.	6.	7.	7.	8.	10.	11.	13.
170.	7.	7.	8.	10.	11.	13.	15.
180.	8.	8.	9.	11.	12.	14.	16.
190.	9.	9.	10.	12.	14.	16.	18.
200.	9.	10.	12.	13.	15.	18.	20.
210.	10.	11.	13.	15.	17.	19.	23.
220.	11.	12.	14.	16.	18.	21.	25.
230.	13.	14.	15.	17.	20.	23.	27.
240.	14.	15.	17.	19.	22.	25.	29.
250.	15.	16.	18.	21.	24.	27.	32.
260.	16.	17.	19.	22.	26.	30.	34.
270.	17.	19.	21.	24.	28.	32.	37.
280.	19.	20.	23.	26.	30.	34.	40.
300.	20.	22.	24.	28.	32.	37.	43.
TENSION							
LBS.	2307.	2124.	1894.	1668.	1452.	1254.	1082.

CLIENT : ELECTRICITIES OF NORTH CAROLINA
 TRANSMISSION LINE : DISTRIBUTION CONDUCTOR SAG DATA
 JOB NUMBER : 96-4385-0001
 DATE : 04-29-1996

***** INITIAL STRINGING SAG TABLE *****

CONDUCTOR DESCRIPTION : 336.4 MCM 18/1 ACSR
 LOADING DISTRICT : MEDIUM
 DESIGN TENSION : 34.5 % ULTIMATE 8680 LBS.
 RULING SPAN : 250.00 FT

SAG IS GIVEN IN INCHES , TO THE NEAREST INCH , FOR EACH SPAN
 AND TEMPERATURE , BASED UPON NO ICE LOAD.

TEMPERATURE - DEGREES F

AN	TEMPERATURE - DEGREES F						
	32	40	50	60	70	80	90
	---	---	---	---	---	---	---
	SPAN SAG - INCHES						
	---	---	---	---	---	---	---
150.	6.	6.	7.	8.	9.	10.	11.
160.	6.	7.	8.	9.	10.	11.	13.
170.	7.	8.	9.	10.	11.	13.	14.
180.	8.	9.	10.	11.	13.	14.	16.
190.	9.	10.	11.	12.	14.	16.	18.
200.	10.	11.	12.	14.	15.	18.	20.
210.	11.	12.	13.	15.	17.	19.	22.
220.	12.	13.	15.	16.	19.	21.	24.
230.	13.	14.	16.	18.	20.	23.	26.
240.	14.	16.	17.	20.	22.	25.	28.
250.	16.	17.	19.	21.	24.	27.	31.
260.	17.	18.	20.	23.	26.	30.	33.
270.	18.	20.	22.	25.	28.	32.	36.
280.	20.	21.	24.	27.	30.	34.	39.
290.	21.	23.	25.	29.	32.	37.	41.
300.	22.	24.	27.	31.	35.	39.	44.
310.	24.	26.	29.	33.	37.	42.	47.
320.	26.	28.	31.	35.	40.	45.	51.
330.	27.	29.	33.	37.	42.	48.	54.
0.	29.	31.	35.	39.	45.	51.	57.
TENSION LBS.	2201.	2027.	1813.	1609.	1420.	1254.	1111.

CLIENT :ELECTRICITIES OF NORTH CAROLINA
 TRANSMISSION LINE :DISTRIBUTION CONDUCTOR SAG DATA
 JOB NUMBER :96-4385-0001
 DATE :04-29-1996

***** INITIAL STRINGING SAG TABLE *****

CONDUCTOR DESCRIPTION :336.4 MCM 18/1 ACSR
 LOADING DISTRICT :MEDIUM
 DESIGN TENSION : 34.5 % ULTIMATE 8680 LBS.
 RULING SPAN : 300.00 FT

SAG IS GIVEN IN INCHES ,TO THE NEAREST INCH ,FOR EACH SPAN
 AND TEMPERATURE ,BASED UPON NO ICE LOAD.

TEMPERATURE - DEGREES F

AN	TEMPERATURE - DEGREES F						
	32	40	50	60	70	80	90
	11.	12.	13.	14.	16.	18.	20.
200.	12.	13.	14.	16.	18.	20.	22.
210.	13.	14.	16.	17.	19.	22.	24.
220.	14.	15.	17.	19.	21.	24.	26.
230.	15.	17.	19.	21.	23.	26.	28.
240.	17.	18.	20.	23.	25.	28.	31.
250.	18.	20.	22.	24.	27.	30.	33.
260.	20.	21.	24.	26.	29.	32.	36.
270.	21.	23.	25.	28.	31.	35.	39.
280.	23.	24.	27.	30.	34.	37.	41.
290.	24.	26.	29.	32.	36.	40.	44.
300.	26.	28.	31.	35.	39.	43.	47.
310.	27.	30.	33.	37.	41.	46.	50.
320.	29.	32.	35.	39.	44.	48.	54.
330.	31.	34.	37.	42.	46.	51.	57.
340.	33.	36.	40.	44.	49.	55.	60.
350.	35.	38.	42.	47.	52.	58.	64.
360.	37.	40.	44.	49.	55.	61.	67.
370.	39.	42.	47.	52.	58.	64.	71.
380.	41.	44.	49.	55.	61.	68.	75.
0.							
TENSION	2047.	1887.	1697.	1522.	1366.	1230.	1116.
LBS.							

CLIENT : ELECTRICITIES OF NORTH CAROLINA
 TRANSMISSION LINE : DISTRIBUTION CONDUCTOR SAG DATA
 JOB NUMBER : 96-4385-0001
 DATE : 04-29-1996

***** INITIAL STRINGING SAG TABLE *****

CONDUCTOR DESCRIPTION : 336.4 MCM 18/1 ACSR
 LOADING DISTRICT : MEDIUM
 DESIGN TENSION : 34.5 % ULTIMATE 8680 LBS.
 RULING SPAN : 350.00 FT

SAG IS GIVEN IN INCHES , TO THE NEAREST INCH , FOR EACH SPAN
 AND TEMPERATURE , BASED UPON NO ICE LOAD.

TEMPERATURE - DEGREES F

 32 40 50 60 70 80 90
 -- -- -- -- -- -- --

SPAN

 SPAN SAG - INCHES

SPAN	32	40	50	60	70	80	90
200.	12.	12.	14.	15.	17.	18.	20.
210.	13.	14.	15.	17.	18.	20.	22.
220.	14.	15.	17.	18.	20.	22.	24.
230.	15.	17.	18.	20.	22.	24.	26.
240.	17.	18.	20.	22.	24.	26.	28.
250.	18.	20.	22.	24.	26.	28.	31.
260.	20.	21.	23.	26.	28.	31.	33.
270.	21.	23.	25.	28.	30.	33.	36.
280.	23.	24.	27.	30.	33.	35.	38.
290.	24.	26.	29.	32.	35.	38.	41.
300.	26.	28.	31.	34.	37.	41.	44.
310.	28.	30.	33.	36.	40.	43.	47.
320.	30.	32.	35.	39.	43.	46.	50.
330.	32.	34.	38.	41.	45.	49.	53.
340.	34.	36.	40.	44.	48.	52.	57.
350.	36.	38.	42.	46.	51.	55.	60.
360.	38.	40.	45.	49.	54.	59.	63.
370.	40.	43.	47.	52.	57.	62.	67.
380.	42.	45.	50.	55.	60.	65.	71.
390.	44.	48.	52.	58.	63.	69.	74.

TENSION

LBS. 1893. 1753. 1592. 1447. 1321. 1212. 1119.

CLIENT :ELECTRICITIES OF NORTH CAROLINA
 TRANSMISSION LINE :DISTRIBUTION CONDUCTOR SAG DATA
 JOB NUMBER :96-4385-0001
 DATE :04-26-1996

***** INITIAL STRINGING SAG TABLE *****

CONDUCTOR DESCRIPTION :1/0 AWG 6/1 ACSR
 LOADING DISTRICT :MEDIUM
 DESIGN TENSION : 36.9 % ULTIMATE 4380 LBS.
 RULING SPAN : 150.00 FT

SAG IS GIVEN IN INCHES ,TO THE NEAREST INCH ,FOR EACH SPAN
 AND TEMPERATURE ,BASED UPON NO ICE LOAD.

TEMPERATURE - DEGREES F

PAN	TEMPERATURE - DEGREES F						
	32	40	50	60	70	80	90
	SPAN SAG - INCHES						
100.	2.	2.	2.	3.	3.	3.	3.
110.	2.	3.	3.	3.	3.	4.	4.
120.	3.	3.	3.	4.	4.	4.	5.
130.	3.	4.	4.	4.	5.	5.	6.
140.	4.	4.	4.	5.	5.	6.	7.
150.	4.	5.	5.	6.	6.	7.	8.
160.	5.	5.	6.	6.	7.	8.	9.
170.	6.	6.	7.	7.	8.	9.	10.
180.	6.	7.	7.	8.	9.	10.	11.
190.	7.	8.	8.	9.	10.	11.	13.
200.	8.	9.	9.	10.	11.	12.	14.
210.	9.	9.	10.	11.	12.	13.	15.
220.	10.	10.	11.	12.	13.	15.	17.
230.	10.	11.	12.	13.	15.	16.	18.
240.	11.	12.	13.	14.	16.	18.	20.
250.	12.	13.	14.	16.	17.	19.	22.
260.	13.	14.	16.	17.	19.	21.	23.
270.	14.	16.	17.	18.	20.	22.	25.
280.	15.	17.	18.	20.	22.	24.	27.
290.	17.	18.	19.	21.	23.	26.	29.
TENSION LBS.	1093.	1031.	952.	872.	792.	711.	631.

CLIENT :ELECTRICITIES OF NORTH CAROLINA
 TRANSMISSION LINE :DISTRIBUTION CONDUCTOR SAG DATA
 JOB NUMBER :96-4385-0001
 DATE :04-26-1996

***** INITIAL STRINGING SAG TABLE *****

CONDUCTOR DESCRIPTION :1/0 AWG 6/1 ACSR
 LOADING DISTRICT :MEDIUM
 DESIGN TENSION : 36.9 % ULTIMATE 4380 LBS.
 RULING SPAN : 200.00 FT

SAG IS GIVEN IN INCHES ,TO THE NEAREST INCH ,FOR EACH SPAN
 AND TEMPERATURE ,BASED UPON NO ICE LOAD.

TEMPERATURE - DEGREES F

SPAN	TEMPERATURE - DEGREES F							
	32	40	50	60	70	80	90	
	2.	2.	2.	2.	3.	3.	3.	
100.	2.	3.	3.	3.	3.	4.	4.	
110.	3.	3.	3.	4.	4.	4.	5.	
120.	3.	4.	4.	4.	5.	5.	6.	
130.	4.	4.	4.	5.	5.	6.	6.	
140.	4.	5.	5.	6.	6.	7.	7.	
150.	5.	5.	6.	6.	7.	8.	8.	
160.	6.	6.	7.	7.	8.	9.	10.	
170.	6.	7.	7.	8.	9.	10.	11.	
180.	7.	8.	8.	9.	10.	11.	12.	
190.	8.	8.	9.	10.	11.	12.	13.	
200.	9.	9.	10.	11.	12.	13.	15.	
210.	10.	10.	11.	12.	13.	14.	16.	
220.	10.	11.	12.	13.	14.	16.	17.	
230.	11.	12.	13.	14.	15.	17.	19.	
240.	12.	13.	14.	15.	17.	19.	21.	
250.	13.	14.	15.	17.	18.	20.	22.	
260.	14.	15.	16.	18.	19.	22.	24.	
270.	16.	16.	18.	19.	21.	23.	26.	
280.	17.	18.	19.	21.	22.	25.	28.	
290.								
TENSION LBS.	1106.	1045.	968.	891.	813.	737.	662.	

CLIENT :ELECTRICITIES OF NORTH CAROLINA
 TRANSMISSION LINE :DISTRIBUTION CONDUCTOR SAG DATA
 JOB NUMBER :96-4385-0001
 DATE :04-26-1996

***** INITIAL STRINGING SAG TABLE *****

CONDUCTOR DESCRIPTION :1/0 AWG 6/1 ACSR
 LOADING DISTRICT :MEDIUM
 DESIGN TENSION : 36.9 % ULTIMATE 4380 LBS.
 RULING SPAN : 250.00 FT

SAG IS GIVEN IN INCHES ,TO THE NEAREST INCH ,FOR EACH SPAN
 AND TEMPERATURE ,BASED UPON NO ICE LOAD.

TEMPERATURE - DEGREES F

SPAN	TEMPERATURE - DEGREES F						
	32	40	50	60	70	80	90
	SPAN SAG - INCHES						
150.	4.	5.	5.	5.	6.	6.	7.
160.	5.	5.	6.	6.	7.	7.	8.
170.	6.	6.	6.	7.	8.	8.	9.
180.	6.	7.	7.	8.	8.	9.	10.
190.	7.	7.	8.	9.	9.	10.	11.
200.	8.	8.	9.	10.	10.	11.	13.
210.	9.	9.	10.	11.	12.	13.	14.
220.	9.	10.	11.	12.	13.	14.	15.
230.	10.	11.	12.	13.	14.	15.	17.
240.	11.	12.	13.	14.	15.	16.	18.
250.	12.	13.	14.	15.	16.	18.	20.
260.	13.	14.	15.	16.	18.	19.	21.
270.	14.	15.	16.	17.	19.	21.	23.
280.	15.	16.	17.	19.	20.	22.	25.
290.	16.	17.	19.	20.	22.	24.	26.
300.	17.	18.	20.	22.	24.	26.	28.
310.	19.	20.	21.	23.	25.	27.	30.
320.	20.	21.	23.	25.	27.	29.	32.
330.	21.	22.	24.	26.	28.	31.	34.
340.	22.	24.	26.	28.	30.	33.	36.
TENSION LBS.	1119.	1060.	985.	910.	836.	764.	693.

CLIENT :ELECTRICITIES OF NORTH CAROLINA
 TRANSMISSION LINE :DISTRIBUTION CONDUCTOR SAG DATA
 JOB NUMBER :96-4385-0001
 DATE :04-26-1996

***** INITIAL STRINGING SAG TABLE *****

CONDUCTOR DESCRIPTION :1/0 AWG 6/1 ACSR
 LOADING DISTRICT :MEDIUM
 DESIGN TENSION : 36.9 % ULTIMATE 4380 LBS.
 RULING SPAN : 300.00 FT

SAG IS GIVEN IN INCHES ,TO THE NEAREST INCH ,FOR EACH SPAN
 AND TEMPERATURE ,BASED UPON NO ICE LOAD.

TEMPERATURE - DEGREES F

SPAN	TEMPERATURE - DEGREES F						
	32	40	50	60	70	80	90
200.	8.	9.	9.	10.	11.	12.	13.
210.	9.	9.	10.	11.	12.	13.	14.
220.	10.	10.	11.	12.	13.	14.	16.
230.	11.	11.	12.	13.	14.	16.	17.
240.	12.	12.	13.	14.	16.	17.	19.
250.	13.	13.	14.	16.	17.	18.	20.
260.	14.	14.	16.	17.	18.	20.	22.
270.	15.	16.	17.	18.	20.	21.	23.
280.	16.	17.	18.	19.	21.	23.	25.
290.	17.	18.	19.	21.	23.	25.	27.
300.	18.	19.	21.	22.	24.	27.	29.
310.	19.	21.	22.	24.	26.	28.	31.
320.	21.	22.	23.	25.	28.	30.	33.
330.	22.	23.	25.	27.	29.	32.	35.
340.	23.	25.	27.	29.	31.	34.	37.
350.	25.	26.	28.	30.	33.	36.	39.
360.	26.	28.	30.	32.	35.	38.	42.
370.	28.	29.	31.	34.	37.	40.	44.
380.	29.	31.	33.	36.	39.	43.	46.
90.	31.	32.	35.	38.	41.	45.	49.
TENSION LBS.	1078.	1020.	949.	878.	808.	741.	678.

CLIENT :ELECTRICITIES OF NORTH CAROLINA
 TRANSMISSION LINE :DISTRIBUTION CONDUCTOR SAG DATA
 JOB NUMBER :96-4385-0001
 DATE :04-26-1996

***** INITIAL STRINGING SAG TABLE *****

CONDUCTOR DESCRIPTION :1/0 AWG 6/1 ACSR
 LOADING DISTRICT :MEDIUM
 DESIGN TENSION : 36.9 % ULTIMATE 4380 LBS.
 RULING SPAN : 350.00 FT

SAG IS GIVEN IN INCHES ,TO THE NEAREST INCH ,FOR EACH SPAN
 AND TEMPERATURE ,BASED UPON NO ICE LOAD.

TEMPERATURE - DEGREES F

32 40 50 60 70 80 90
 -- -- -- -- -- -- --

PAN

SPAN SAG - INCHES

	32	40	50	60	70	80	90
200.	9.	10.	11.	11.	12.	14.	15.
210.	10.	11.	12.	13.	14.	15.	16.
220.	11.	12.	13.	14.	15.	16.	18.
230.	12.	13.	14.	15.	16.	18.	19.
240.	13.	14.	15.	17.	18.	19.	21.
250.	15.	15.	17.	18.	19.	21.	23.
260.	16.	17.	18.	19.	21.	23.	25.
270.	17.	18.	19.	21.	23.	25.	27.
280.	18.	19.	21.	23.	24.	26.	29.
290.	20.	21.	22.	24.	26.	28.	31.
300.	21.	22.	24.	26.	28.	30.	33.
310.	22.	24.	26.	28.	30.	32.	35.
320.	24.	25.	27.	29.	32.	35.	38.
330.	25.	27.	29.	31.	34.	37.	40.
340.	27.	28.	31.	33.	36.	39.	42.
350.	28.	30.	33.	35.	38.	41.	45.
360.	30.	32.	34.	37.	40.	44.	47.
370.	32.	34.	36.	39.	43.	46.	50.
380.	34.	36.	38.	41.	45.	49.	53.
390.	35.	37.	40.	44.	47.	51.	56.

TENSION
LBS.

939. 886. 821. 759. 700. 645. 595.

Appendix I: Soil Boring Report

[Balance of Page Left Blank Intentionally]

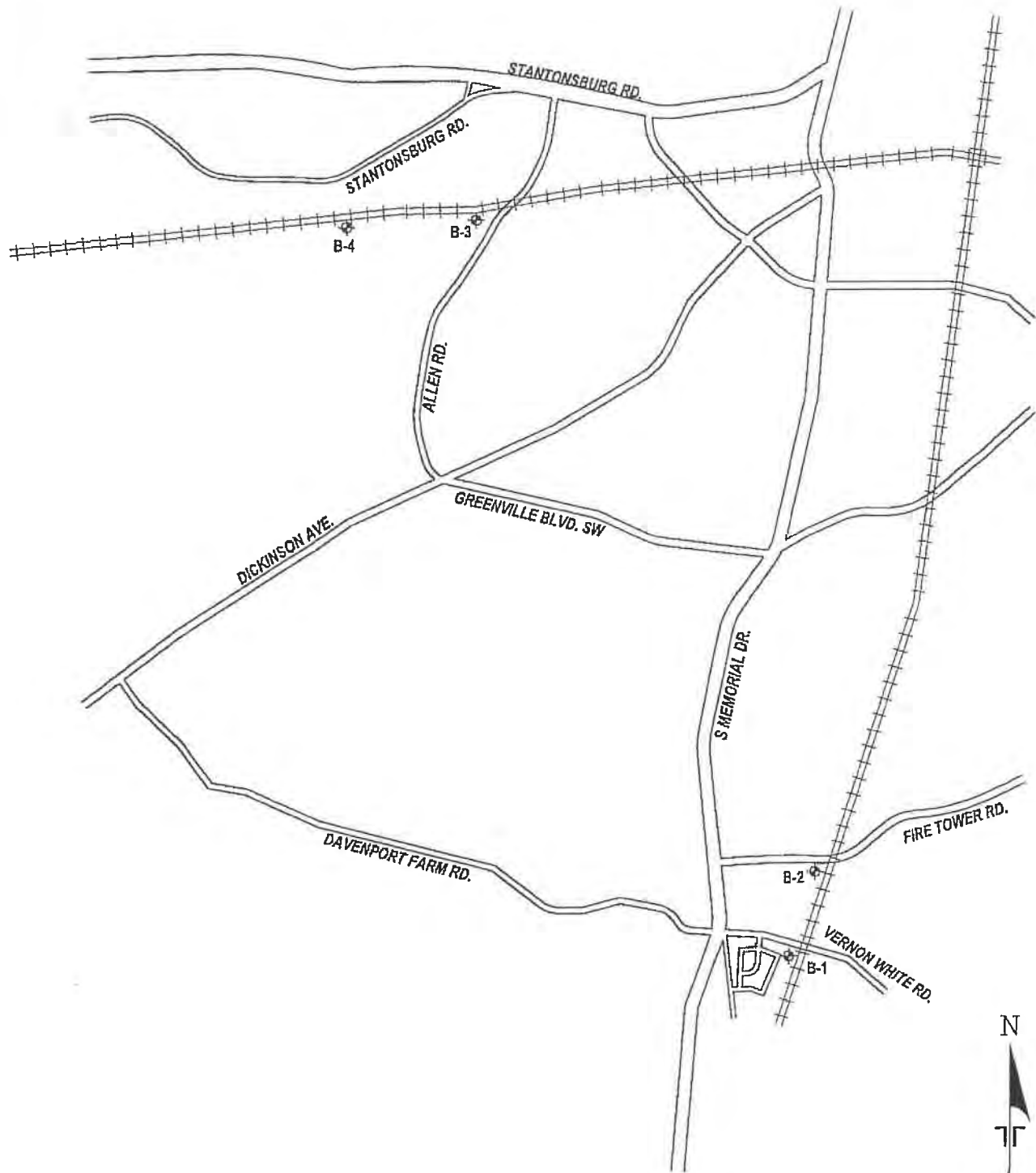

LEGEND



APPROXIMATE BORING LOCATION

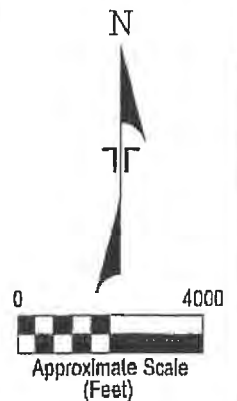

THIS DIAGRAM IS FOR GENERAL LOCATION ONLY, AND IS NOT INTENDED FOR CONSTRUCTION PURPOSES

Project Mgr:	LG
Drawn By:	DWD
Checked By:	LG/MRF
Approved By:	CB
Project No.	72085050
Scale:	AS SHOWN
File No.	GE072085050-3
Date:	AUGUST 2008

Terracon
Consulting Engineers and Scientists

314 Beacon Drive Winterville, NC 28590
(252) 353-1600 (252) 353-0002

BORING LOCATION DIAGRAM
GEOTECHNICAL ENGINEERING REPORT
PROPOSED POWER TRANSMISSION POLES
GREENVILLE AND WINTERVILLE, NC

FIG. No.
2

LOG OF BORING NO. B-3

CLIENT Greenville Utilities Commission										
SITE Greenville and Winterville, North Carolina		PROJECT Proposed Power Transmission Poles								
GRAPHIC LOG	Boring Location: Landfill Road		DEPTH, ft.		SAMPLES				TESTS	
	DESCRIPTION		USCS SYMBOL	NUMBER	TYPE	RECOVERY, in.	SPT - N BLOWS / ft.	WATER CONTENT, %	DRY UNIT WT pcf	UNCONFINED STRENGTH, psf
	2	BRUSH AND TOPSOIL (Approx. 24")		SC	1	SS		3		
	3	SLIGHTLY CLAYEY FINE SAND with Silt, Dark Brown and Yellow Brown, Very Loose, Moist c=0 psf $\phi=28^\circ$ $\gamma=100$ pcf		SM						
	5.0	CLAYEY FINE SANDY CLAY, Orange Brown, Dark Gray, Light Gray and Tan Orange, Soft to Medium Stiff, Moist c=600 psf $\phi=0^\circ$ $\gamma=110$ pcf		CL	2	SS		4		
	8	CLAYEY FINE TO MEDIUM SAND with Silt, Light Gray and Tan Orange, Loose, Moist to Wet c=0 psf $\phi=30^\circ$ $\gamma=110$ pcf		CL	3	SS		6		
	10.0	CLAYEY FINE TO MEDIUM SAND with Silt, Light Gray and Tan Orange, Loose, Moist to Wet c=0 psf $\phi=32^\circ$ $\gamma=120$ pcf		SC	4	SS		6		
	13	CLAYEY FINE TO MEDIUM SAND with Silt, Light Gray and Tan Orange, Loose, Moist to Wet c=0 psf $\phi=30^\circ$ $\gamma=110$ pcf								
	15.0	SILTY FINE TO MEDIUM SAND, Light Gray and Dark Gray, Loose to Medium Dense, Wet c=0 psf $\phi=32^\circ$ $\gamma=120$ pcf		SM	5	SS		12		
	20.0			SM	6	SS		8		
25.0			SM	7	SS		16			
30.0			SM	8	SS		20			
BORING TERMINATED										

The stratification lines represent the approximate boundary lines between soil and rock types: in-situ, the transition may be gradual.

WATER LEVEL OBSERVATIONS, ft

WL	▽ 10	3-Days	▽
WL	▽		▽
WL			



BORING STARTED		8-19-08	
BORING COMPLETED		8-19-08	
RIG	CME 45	FOREMAN	GE
APPROVED	LG	JOB #	72085050

BOREHOLE 99 72085050 PROPOSED POWER TRANSMISSION POLES, GREENVILLE, NC.GPJ GAGE TERRACON.GDT 8/22/08